

OWL CREEK PARK

PLAYGROUND EQUIPMENT MANUFACTURER'S INSTALLATION INSTRUCTIONS

INSTALLATION MANUAL

2.1.2010

IMPORTANT! THIS MANUAL CONTAINS:

- Construction Views
- General Installation Guidelines
- Maintenance & Safety Information

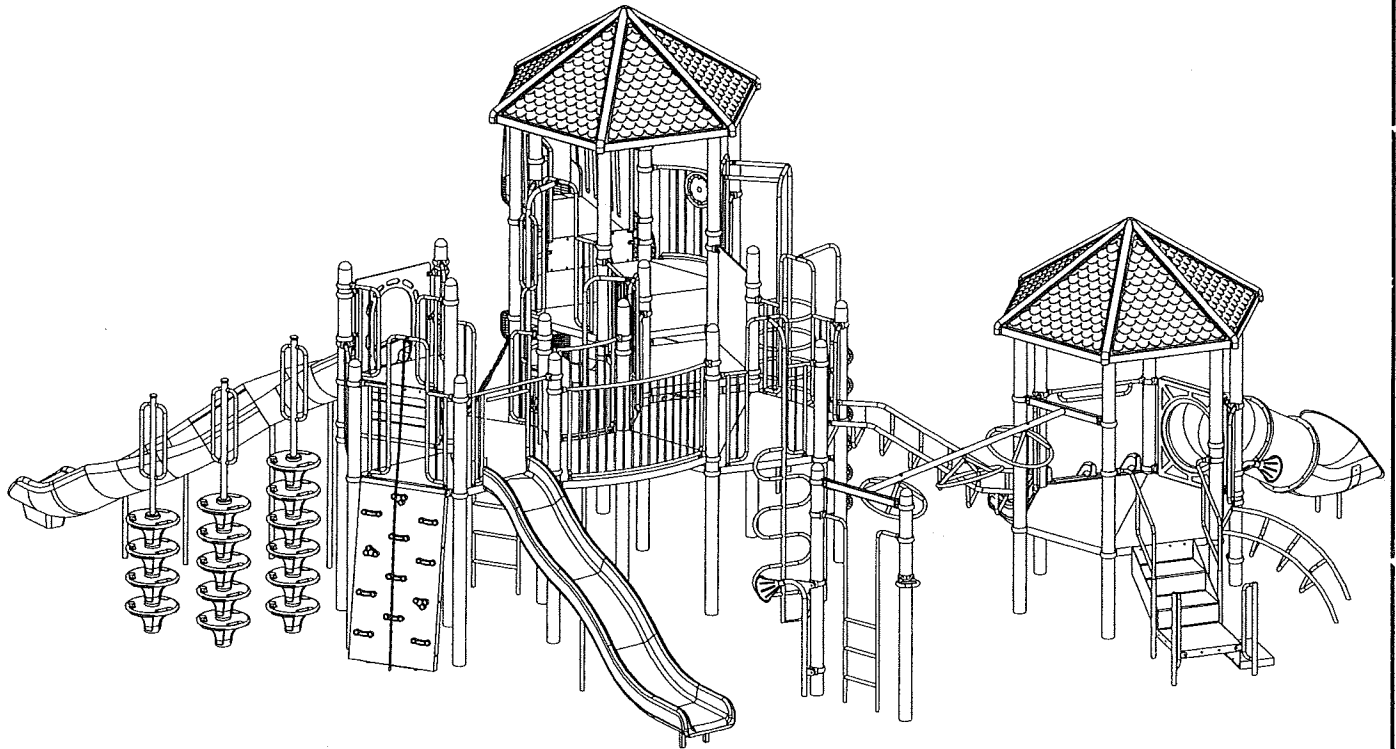

WARNING: Read all instructions thoroughly before installation. Improperly assembled playground equipment can present a serious safety hazard. Acceptable impacts absorbing surfacing is required under and around all play structures and must be maintained.

If you have any questions during assembly, please contact your Playcraft Representative or:

Krauss Craft, Inc.

123 North Valley Road, Grants Pass, OR 97526

Phone: 800-333-8519 Fax: 541-955-6130

INSTALLATION MANUAL CONTENTS

R5 - 01 (1 OF 5)

CONTAINS ASSEMBLY INSTRUCTIONS FOR PLAYCRAFT SYSTEMS WITH:	PROJECT NAME:
ROUND 5 - STEEL POSTS	OWL CREEK PARK

<input checked="" type="checkbox"/>	STANDARD INSTRUCTIONS INCLUDED WITH THIS MANUAL:	SECTION
<input checked="" type="checkbox"/>	Construction Drawings (Top View, Perspective Views, Site Plan, Color Rendering)	R5 - 02
<input checked="" type="checkbox"/>	General Installation Guidelines	R5 - 03.1 & 03.2
<input checked="" type="checkbox"/>	General Safety Recommendations	R5 - 04.1 & 04.2
<input checked="" type="checkbox"/>	Support Posts & Hardware	R5 - 05
<input checked="" type="checkbox"/>	Concrete Footings	R5 - 06.1 & 06.2
<input checked="" type="checkbox"/>	Safety / Warning Labels	R5 - 07
<input checked="" type="checkbox"/>	General Maintenance	R5 - 08
<input checked="" type="checkbox"/>	Collars (2 Pages)	R5 - 09
<input checked="" type="checkbox"/>	General Hardware Applications (socket clamps and mounting hardware) (8 Pages)	R5 - 10 to 13

R5 INSTRUCTIONS FOR OPTIONS:

<input checked="" type="checkbox"/>	ACTIVITY	PAGE	<input checked="" type="checkbox"/>	ACTIVITY	PAGE
	Bouncer	1940		Climber, Access	1257
	Boogie Board	1941		Climber, Arch	1218
	Boogie Board, Dual	1942		Climber, Arch (Deep Rung)	1219
				Climber, Arch Twist	1281
	Bridge, Arch (Inclined) 45"	1514		Climber, Arched Wall	1286
	Bridge, Arch (Short) 45"	1501		Climber, Bedrock	1228-34/56
	Bridge, Arch (Long) 90"	1502		Climber, Bubble Angled/PLT	1277/PLT
	Bridge, Arch 45" Village	1501-VIL		Climber, Centipede	1220
	Bridge, Belt 45"	1504-45		<input checked="" type="checkbox"/> Climber, Chain Net	1221
	Bridge, Burma	1509		Climber, Chain Net Handhold	1221-HH3
	Bridge, Chain Net	1505		Climber, Chain Net w/ Side Rails	1221-A
	Bridge, Challenge	1513		Climber, Clever	1231
	Bridge, Curved (45°)	1511		Climber, Clover	1230
	Bridge, Incline Loop Link	1508		Climber, Crater Single	1259
	Bridge, Drop Loop Link	1516		Climber, Crater Wall Double	1260
	Bridge, Marsh	1519		Climber, Cross Loop	1229
	Bridge, Net Link	1521		Climber, Cube	1958
	Bridge, Ribbon	1518		Climber, Disc Pole 3'H /4'H /5'H /6'H	1243-3/4/5/6
	Bridge, Suspension w/ Rails	1506	<input checked="" type="checkbox"/>	Climber, Disc 3' / 4' / 5' / 6'	1233
	Bridge, Suspension w/ Walls	1506-W		Climber, Expansion	1270
	Bridge, Swinging	1507		Climber, Freeform	1238
				Climber, Freeform Ring	1238-RC
				Climber, Freeform to Post	1254
	Chain / Tightrope	1510		Climber, Geo-Wave Horizontal	1249-DDH/DGH
	Raised Loop Link	1515		Climber, Geo-Wave Grnd-Deck Vert	1249-DGV
	Drop Loop Link	1516		Climber, Grip	1216
	Bridge Step-To-Step	1512		Climber, Grip Deluxe	1216-DLX
				Climber, Grip Ramp Curved	1216-CRV
				Climber, Hoop	1241
				Climber, Ladder	1235
				Climber, Ladder-Deck to Deck	1242
				Climber, Ladder-6-Rung Post -Post	1244-6
				Climber, Leaf Ladder	1251
				Climber, Loop 270 degree	1280
				Climber, Matrix	1267
				Climber, Mesh Rope	1957
				Climber, Ribbon	1268
				Climber, Side 4'H / 5'H	1226
				Climber, Side to Post (2 Posts)	1226-DSC
				Climber, Side to 1 Post	1226-1P
				Climber, Side Step	1262

R5 INSTRUCTIONS FOR OPTIONS: (Continued)

R5 – 01 (4 OF 5)

<input checked="" type="checkbox"/>	ACTIVITY	PAGE
	Slide, Accelerator	1714
	Slide, Poly Single 24"H	1701-2
	Slide, Poly Single 36"H	1701-3
	Slide, Poly Single 36"H - Canada	1701-3-CAN
√	Slide, Poly Double	1702
	Slide, Poly Double - Canada	1702-Can
	Slide, Poly Wave	1704
	Slide, Poly Wave - Canada	1704-Can
	Slide, Quarter Turn	1705
	Slide, Quarter Turn - Canada	1705-Can
	Slide, Spiral 6'H Options	1706-6 / 6-HW
	Slide, Spiral Aluminum 6'H	1706-6-STL
	Slide, Steel Single	1711
	Slide, Steel Double	1712
	Slide, Twister	1710
	Slide, Twister Triple	1710-3
	Slide, Twister Triple Canada	1710-3-Can
	Slide, Banister	1709
	Slide, Tube 3 Sec. 36"H	1707-3
	Slide, Tube 4 Sec. 48"H	1707-4
	Slide, Tube 4 Sec. Curved 48"H	1707-4C
	Slide, Tube 4 Sec. S-Shaped 48"H	1707-4S
	Slide, Tube 5 Sec. 60"H	1707-5
	Slide, Tube 5 Sec. 60"H L-Shaped	1707-5L
	Slide, Tube 5 Sec. Curved 60"H	1707-5C
	Slide, Tube 5 Sec. S-Shaped 60"H	1707-5S
	Slide, Tube 6 Sec. 72"H	1707-6
	Slide, Tube 6 Sec. Curved 72"H	1707-6C
	Slide, Tube 6 Sec. L-Shaped 72"H	1707-6L
	Slide, Tube 6 Sec. S-Shaped 72"H	1707-6S
	Slide, Tube 6 Sec. 84"	1707-7
	Slide, Tube 6 Sec. L-Shaped 96"H	1707-8L
	Slide, Tube 8 Sec. S-Shaped 96"H	1707-8S
	Slide, Tube 6 Sec. Spiral 96"H	1707-8SP
	Slide, Tube 9 Sec. 120"H	1707-9
	Slide, Tube 9 Sec. S-Shaped 108"	1707-9S
	Slide, Tube 9 Sec. S-Shaped 120"	1707-10S
	Slide, Tube 7 Sec. Spiral 108"H	1707-9SP
	Slide, Tube 6 Sec. U-Shaped 108"H	1707-9U
	Slide, Tube 11 Sec. 144"H	1707-12
	Slide, Tube 11 Sec. Spiral 156"H	1707-13SP
	Slide, Tube 11 Sec. S-Shaped 156"	1707-13S
	Tube Supports	1708
	Tube Support Horizontal	1708-HORZ
	Ring Pull-Up	1936
	Rocker	1946
	Ramp, Wheelchair 12'	1208-RLWL
	Revolution, Cross Member 45"	1440

<input checked="" type="checkbox"/>	ACTIVITY	PAGE
√	Sit-Down Bar, Double Slide	1305
	Sit-Down Bar, Dbl. – Canada	1305-CAN
	Sit-Down Bar, Double Slide Steel	1305-STL
	Sit-Down Wall, Single Slide	1304
	Sit-Down Wall, Single - Canada	1304-CAN
	Sit-Down Wall, Single Slide Steel	1304-STL
	Sit-Down Wall, Single Slide 24"H	1304-2
	Sit-Down Hood Single	1303
	Sit-Down Hood Double	1306
	Sit-Down, Twister	1316
	Sit-Down, Twister Canada	1316-Can
	Sit-Down Triple Twister Entry	1317
	Stairs 2'H / 4'H / 5'H Rise	1201-2/4/5
	Stairs 36"H Rise	1203
	Stairs 72"H Rise	1204
	Stairs 96"H Rise	1201-8
	Spinner, Gyro Pod	1966
	Step to Step Link	1512
	Step Pad on Post	1964
	Surf Rider	1948
√	Steps, ADA w/ Walls 12"H / 18"H	1206-12/18
	Steps, ADA w/ Walls & Handles 12"H	1206-2HND
	Steps, ADA w/ Walls 24"H	1206-24
	Steps, ADA w/ Walls 24"H x 46"	1206-24-45
	Steps, ADA w/ Walls 30"H	1206-30
	Steps, ADA w/ Walls 36"H	1206-36
	Steps, ADA w/ Walls 36"H x 96"L	1206-36-96
	Steps, ADA w/ Walls 48"H	1206-48
	Step Deck	1202-12
	Post Topper, Freeform - Med.	1844
	Post Topper, Freeform – Lg.	1845
	Boom for Post	1835
	Topper, Palm	1840
	Topper, Post	1843/4/5
	Talk Tubes	1910
	Talk Tubes, Tall	1910-12/60
	Telescope on Post	1831
	Telescope HDPE / Steel Wall	1830
	Transfer Station 12-24	1209-12
√	Transfer Station 12-36	1209-24
	Transfer Station 12-36 Half Walls	1209-24HW
	Transfer Station 12-36 +6"	1209-24+6
	Transfer Station 12-42	1209-30
	Transfer Station 12-42 + 6"	1209-30+6
	Transfer Station 12-48	1209-36/36HW
	Transfer Station 12-60	1209-48
	Transfer Station 14-36 (California)	1209-22CA
	Transfer Station 14-48 (California)	1209-34CA
	Transfer Station 16-48	1209-32

PLEASE NOTE: The pages enclosed in this section (between the yellow sheets) are the construction drawings for the specific job listed in the label below.

P.O.#:	101410AP-12/1/10
PROJECT NAME:	OWL CREEK PARK
REP/ CUSTOMER:	PLAY FOCUSED SOLUTIONS
PHONE NUMBER:	866-414-8220

WARNING: Read all instructions thoroughly before installation. Improperly assembled playground equipment can present a serious safety hazard. Acceptable impact absorbing surfacing is required under and around all play structures and must be maintained.

If you have any questions during assembly, please contact your Playcraft Representative or:

Krauss Craft, Inc.

123 North Valley Road, Grants Pass, OR 97526
Phone: 800-333-8519 Fax: 541-955-6130

CUSTOM ROUND 5 MODULAR PLAYSYSTEM

Top View

- DENOTES POST LENGTH
- DENOTES DECK HEIGHT
- ◇ DENOTES DECK FILLER

NOTES:

1. Post footing dimensions are from centers of support posts.
2. Deck heights shown are finished heights at top of decks above ground cover. Adjust footing depth of support posts, compensating for required ground cover depth.
3. This structure is accessible by transfer point.
4. This structure meets the USCPSC & ASTM guidelines for playground safety.
5. This equipment was designed for use by children 5-12 years of age.
6. **IMPORTANT:** An impact absorbing safety surface is required under and around all playground equipment.

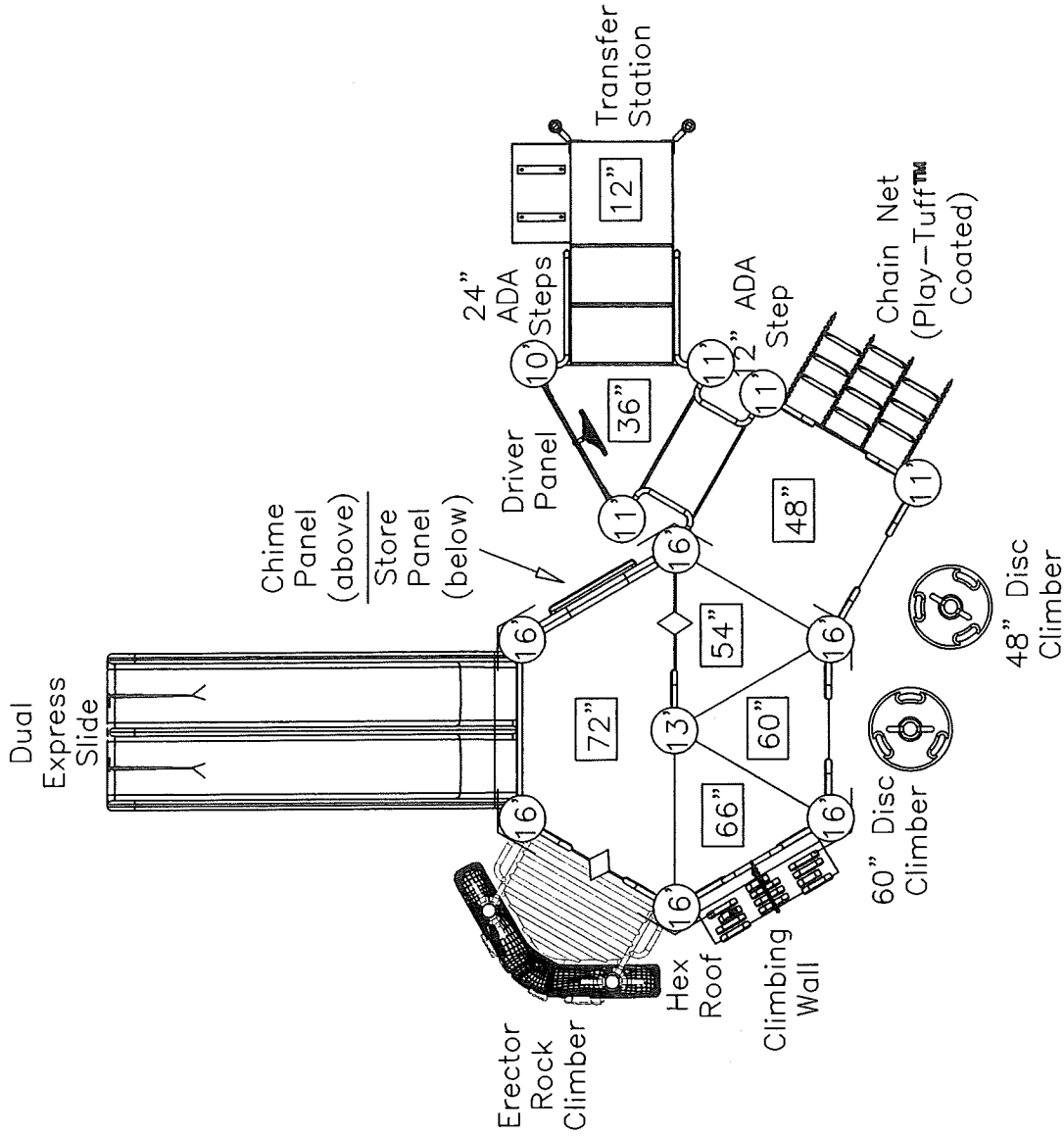

ADA ACCESSIBILITY GUIDELINE - ADAAG CONFORMANCE:
 THIS DESIGN WILL MEET ADAAG AND ASTM F 1487-07a #1 REQUIREMENTS FOR ACCESS TO THE ADDITION OF 1 GROUND LEVEL EVENT (1 TYPE) WHEN PROPERLY INSTALLED OVER ACCESSIBLE SURFACING. SEE SITE PLAN FOR ADDITIONAL GROUND LEVEL EVENTS.
 ELEVATED ACCESSIBLE RAMP ACCESSIBLE GROUND TYPES

7 7/4 0/0 1/2 1/2

FOR KIDS AGES 5-12

PO#: 101410AP-12/1/10
 Date: 12/08/10
 Drawn By: SMN

OWL CREEK PARK

Play Focused Solutions

Dimensions: 19' x 19'
 Min. Use Zone: 31' x 31'
 Scale: 1/4" = 1'-0"



CUSTOM ROUND 5 MODULAR PLAYSYSTEM

Front Perspective

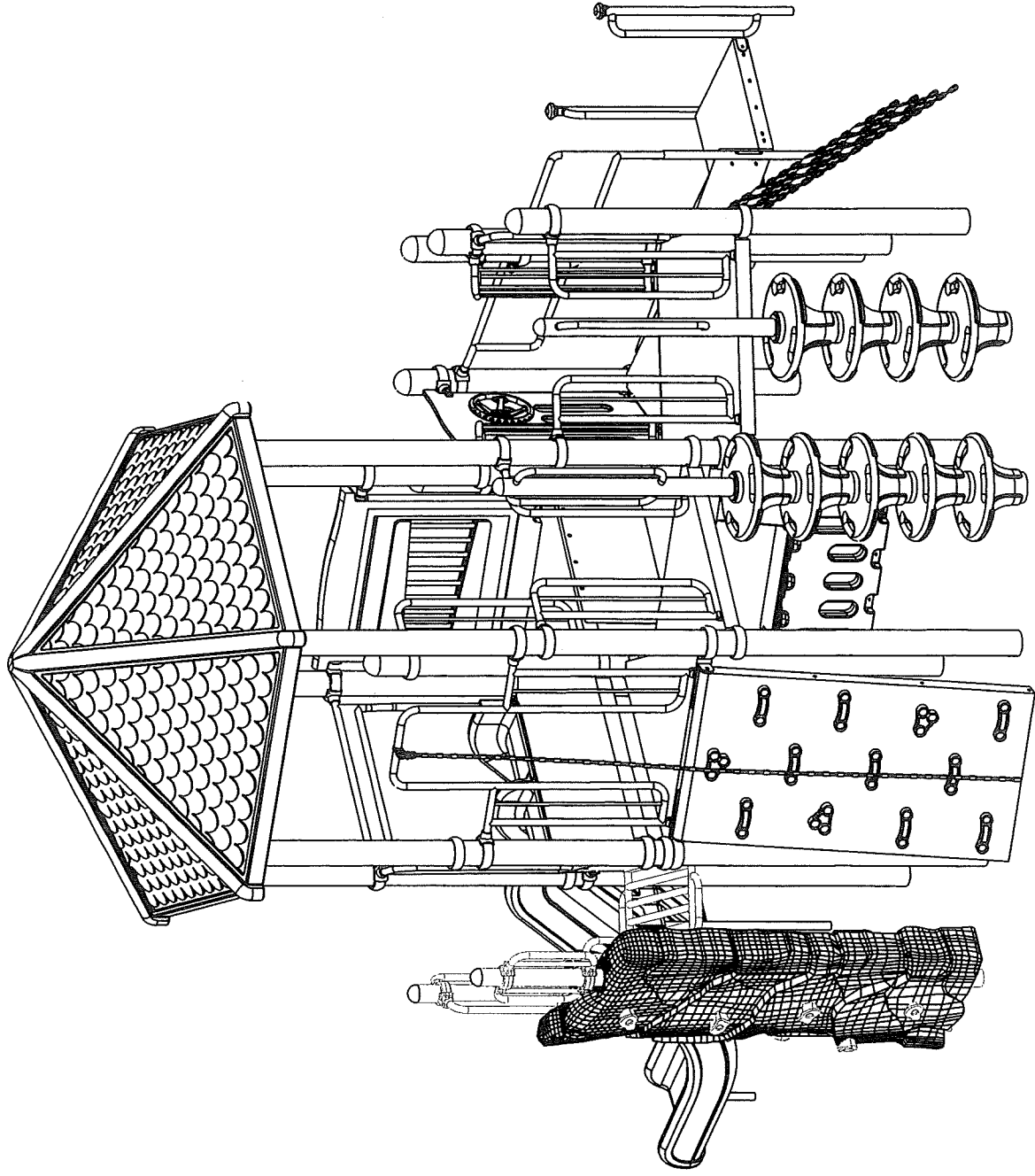

PO#: 101410AP-12/1/10
Date: 12/08/10
Drawn By: SMN

OWL CREEK PARK
Play Focused Solutions



123 NORTH VALLEY DRIVE
GRANTS PASS, OR 97526
PH: 541-955-9199
FAX: 541-955-6130
www.playcraftsystems.com

CUSTOM ROUND 5 MODULAR PLAYSYSTEM

Back Perspective

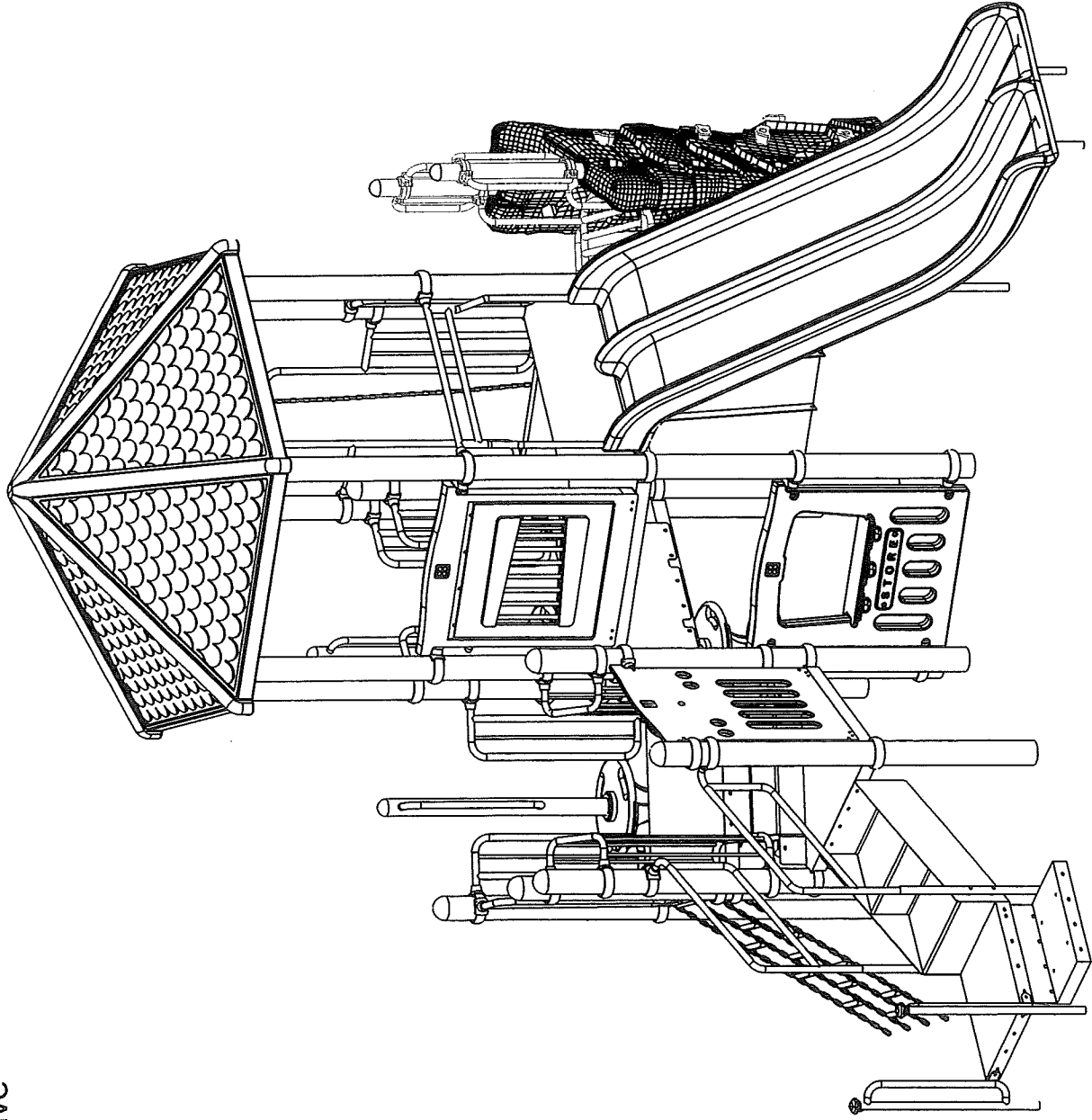

PO#: 101410AP-12/1/10
Date: 12/08/10
Drawn By: SMN

OWL CREEK PARK
Play Focused Solutions



123 NORTH VALLEY DRIVE
GRANTS PASS, OR 97526
PH: 541-955-9199
FAX: 541-955-6130
www.playcraftsystems.com

CUSTOM ROUND 5 MODULAR PLAYSYSTEM

Site Plan (Preliminary)

ADA ACCESSIBILITY GUIDELINE - ADAAG CONFORMANCE:
 THIS DESIGN WILL MEET ADAAG AND ASTM F 1487.07 a e1 REQUIREMENTS FOR ACCESS
 THE ADDITION OF 1 GROUND LEVEL EVENT (1 TYPE) WHEN PROPERLY INSTALLED OVER
 ACCESSIBLE SURFACING.

ELEVATED	ACCESSIBLE	RAMP ACCESSIBLE	GROUND	TYPES
7	7/4	0/0	1/2	1/2

FOR KIDS
 AGES
5-12

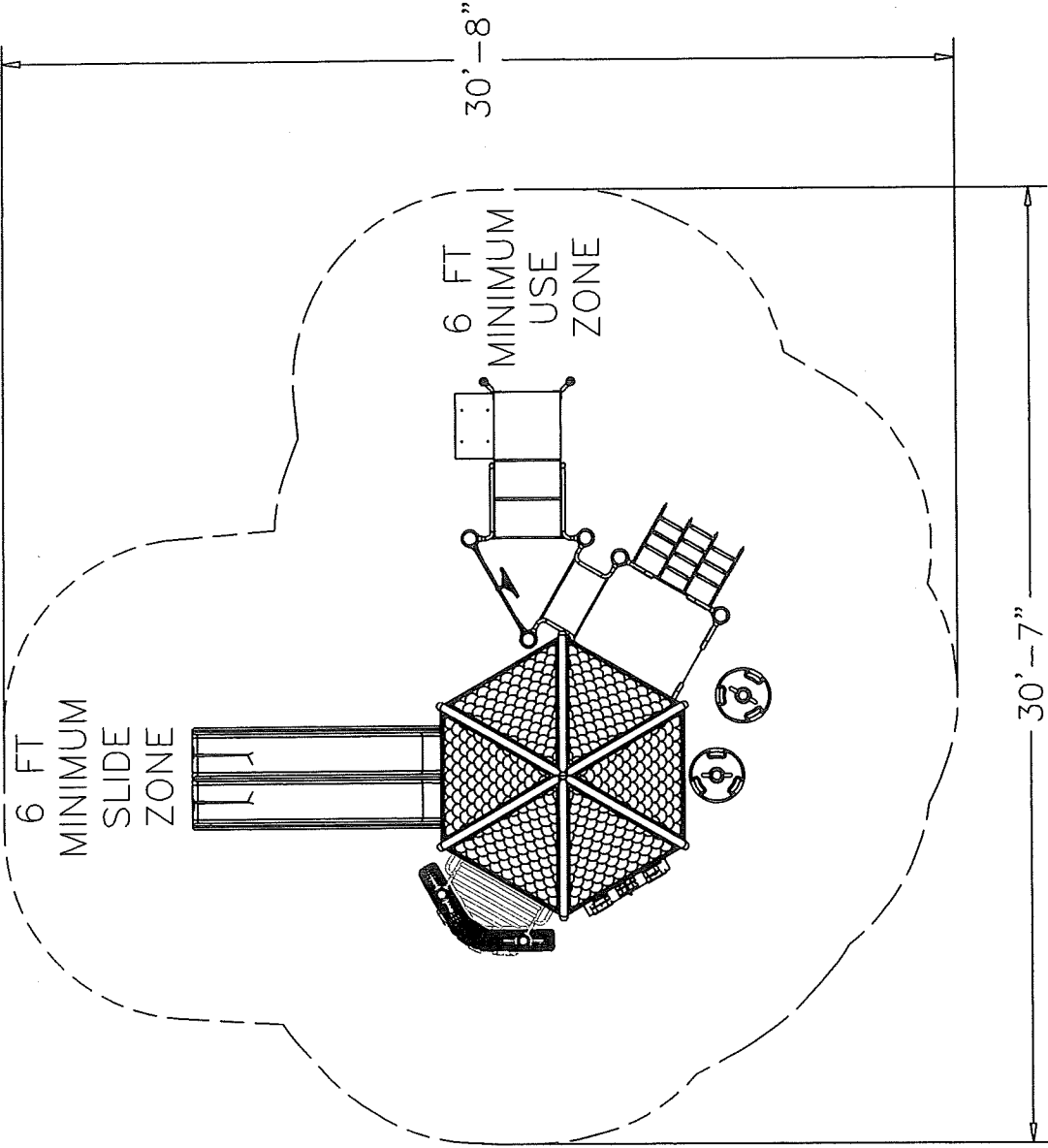

GENERAL NOTES:

- THE SITE PLAN SHOWN IS BASED ON MEASUREMENTS THAT WERE PROVIDED TO KRAUSS CRAFT, INC. AT THE TIME OF THE PROPOSAL REQUEST. ALL DIMENSIONS MUST BE VERIFIED PRIOR TO THE SUBMISSION OF A PURCHASE ORDER.
- KRAUSS CRAFT, INC. WILL NOT BE RESPONSIBLE FOR ANY DISCREPANCIES BETWEEN ACTUAL DIMENSIONS AND DIMENSIONS SUBMITTED ON A PROPOSAL REQUEST.
- THE MINIMUM USE ZONE FOR THE PLAY STRUCTURE IS BASED ON THE PRODUCT DESIGN AT THE TIME OF THE PROPOSAL. COMPONENTS AND STRUCTURE DESIGN MAY BE SUBJECT TO CHANGE WHICH MAY AFFECT DIMENSIONS. THEREFORE, BEFORE PREPARING SITE, WE STRONGLY RECOMMEND OBTAINING FINAL DRAWINGS FROM THE FACTORY (AVAILABLE AFTER THE ORDER IS PLACED AND INCLUDED IN THE ASSEMBLY MANUAL).
- **WARNING:** ACCESSIBLE SAFETY SURFACING MATERIAL IS REQUIRED BENEATH AND AROUND THIS EQUIPMENT THAT HAS A CRITICAL HEIGHT VALUE (FALL HEIGHT) APPROPRIATE FOR THE HIGHEST ACCESSIBLE PART OF THIS EQUIPMENT. REFER TO THE CPSC'S HANDBOOK FOR PUBLIC PLAYGROUND SAFETY, SECTION 4: SURFACING.

PO#: 101410AP-12/1/10

Date: 12/08/10

Drawn By: SMN

OWL CREEK PARK
 Play Focused Solutions

Scale: 1" = 6'-0"



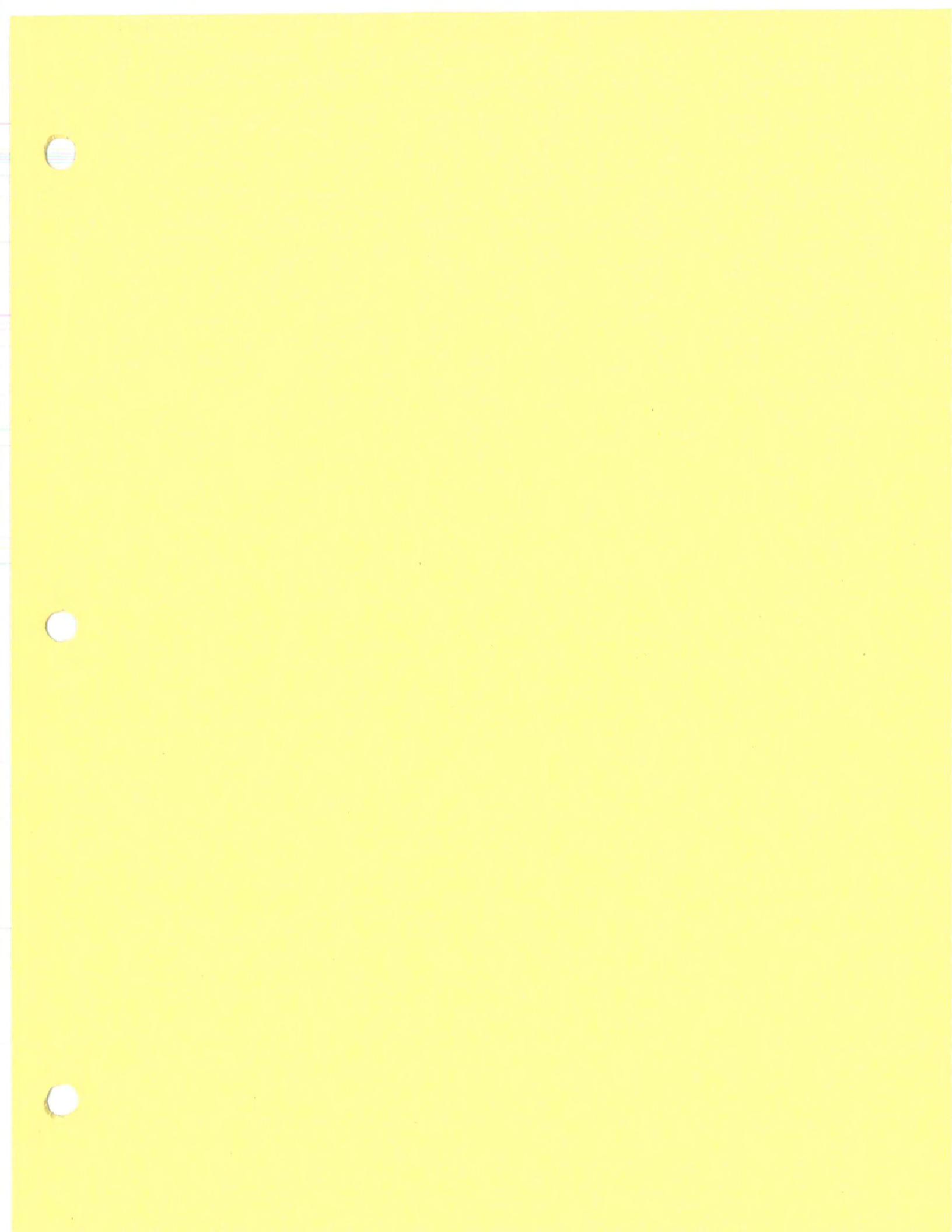

GENERAL INSTALLATION GUIDELINES

R5 - 03.1

R5 - 03.1.1 PLEASE READ THE FOLLOWING VERY CAREFULLY BEFORE INSTALLATION

- 1** **IMPORTANT:** Due to the wide variety, modularity and flexibility of our products, we found it necessary to publish these general installation guidelines. These guidelines are intended for use by experienced playground equipment installers and/or general contractors skilled in assembly and installation of playground equipment. As with any project, general construction knowledge and professional judgment may be required. If any questions or concerns arise during the installation or maintenance of your equipment, please contact the factory and ask to speak to a customer service representative at 1-800-333-8519.
- 2** As an installer of Playcraft Playground Equipment you are responsible for understanding the recommendations for surfacing and providing an appropriate impact attenuating safety surface material. The owner of the playground equipment is responsible for maintaining an appropriate level of impact attenuating safety surface material under and around all playground equipment.
- 3** **ATTENTION INSTALLER:** Upon completion of project, the Playground Equipment Manual w/ Maintenance Kit and all of its contents must be given to the owner of this playground equipment for retention as a product and safety reference and as guidelines for preventative maintenance. **Please make it clear to the owner that the Playground Equipment Manual and Maintenance Kit are to be kept on hand at the playground site at all times.**
- 4** Read all instructions thoroughly before installation. Improperly assembled playground equipment can present a serious safety hazard. Acceptable impact attenuating surfacing is required under and around all play structures and must be maintained.
- 5** In addition to the guidelines found in this manual, all equipment purchases shall include a minimum of (1) Top View drawing and (1) Perspective View drawing specific to each piece of equipment. These views are enclosed between two yellow sheets marked "Construction Drawings".

R5 - 03.1.2 TOOLS REQUIRED:

You will need the following tools for installation:

Adjustable End Wrenches	Electric Extension Cord	Pencils (marking collar locations)	Safety Glasses
Allen Wrenches	Hacksaw	Post Hole Digger	Shovel / Spade
Carpenter's Level	Hammer	Pry Bar	Steel Rake
Combination Wrenches	Impact Driver	Ratchet Set	Tape Measure
Drill & Bits	Liquid Thread Lock (LOCTITE®)	Rubber Mallet	Wheelbarrow

R5 - 03.1.3 TIGHTENING TORQUE FOR HARDWARE (SCREWS, BOLTS AND NUTS):

Tighten all screws, bolts and nuts snugly. After fasteners are snugly tightened, turn nuts and screws an additional one-half turn. **IMPORTANT:** Set screws should be turned an additional full turn after snug tightening. Once equipment or components are fully assembled with hardware tightened/torqued, any excess threads (more than two) extending past the nut should be cut off and filed smooth. **Use liquid thread lock (such as LOCTITE® Threadlocker) with all threaded hardware.**

WARNING: Liquid thread lock (prior to curing) helps to eliminate the common problem of "thread seizure" in stainless steel hardware by serving as a lubricant during assembly.

R5 - 03.1.4 GENERAL INSTALLATION GUIDELINES

- 1** Before you begin, read completely through all instructions carefully.
- 2** Identify all structural components included with your order. Check parts against your packing slip.
- 3** Refer to Section R5 - 04.2 for safe playground layout as well as the top view(s) and/or site plan included with your purchase for accurate information on equipment layout. Confirm the equipment you purchased and its use zones will fit in your site. Site layout is a critical part of overall installation. A clear level site is required for proper installation.
- 4** While referring to the footing diagram in Section R5 - 06.1 and top view(s) provided, identify each post and excavate each hole, one at a time, as assembly progresses. When referring to the footing specifications included with these instructions, adjustments must be made to compensate for depth/thickness requirements of the selected impact attenuating safety surface (i.e. wood chips vs. rubber matting).

IMPORTANT: If soil conditions are loose or unstable, larger diameter footings are required. Inquire with local contractors for appropriate recommendations.

GENERAL INSTALLATION GUIDELINES

R5 - 03.2

R5 - 03.1.4 GENERAL INSTALLATION GUIDELINES (Continued)

5	While referring to the following assembly instructions, erect the equipment (main structure first) and plumb and level as you proceed.
6	Do not fully tighten hardware until assembly is complete.
7	Once assembly is complete, with the equipment plumb and level, tighten the hardware and pour the concrete. All concrete must cure for at least 72 hours prior to being disturbed.
8	Affix Surfacing Level, Hard Surface Warning and Designed for Ages (age appropriate) warning labels to equipment. Labels should be placed in a conspicuous area such as by the main equipment access point. Additional labels should be included with larger designs. For replacement or additional warning labels, please contact customer service at 1-800-333-8519. (Refer to Sections R5 – 07.2 & 07.3 for label type and correct placement)
9	WARNING: Never install play equipment over bare concrete, asphalt, or bare ground. Always use a resilient impact attenuating safety surface. Loose-fill safety surface should not be installed over concrete or asphalt.
10	<p>Do not let children play on or near play equipment until assembly and installation is complete and an impact attenuating safety surface is installed.</p> <p>The impact attenuation of the protective surfacing under and around playground equipment should be rated to have a critical height value of at least the height of the highest accessible part of the equipment. To determine the highest accessible part of equipment, refer to the current publication of the CPSC, "Handbook for Public Playground Safety", Publication 325 at www.cpsc.gov. The critical height for surfacing is to be rated in accordance with ASTM 1292, "A Standard Specification for Impact Attenuation of Surface Systems Under and Around Playground Equipment". The CPSC "Handbook for Public Playground Safety" also provides a table of critical heights for selected loose fill materials. Contact the manufacturer of unitary surfacing materials (rubber matting) for the critical height ratings for their products.</p> <p>The entire area, under and around the playground equipment, must be covered with an impact attenuating surfacing material. Refer to the current publication of the CPSC, "Handbook for Public Playground Safety" for recommendations on the type and depth of the impact attenuating surfacing material.</p> <p>For a copy of the current publication of the CPSC "Handbook for Public Playground Safety" Write To: U.S. Consumer Product Safety Commission Call Toll Free: 1-800-638-2772 Office of Information and Public Affairs Visit the C.P.S.C. web site: www.cpsc.gov Washington, D.C. 20207</p>
11	Good drainage around structural supports is important. Locations under swings and at the end of slides (because they tend to become the lowest points) need the most active drainage. Inquire with local contractors for appropriate recommendations.
12	Many surfacing materials can become compacted due to weather and use, which reduces their shock absorbency. It is strongly recommended that the surfacing be checked weekly and material added or replaced as necessary.

R5 - 03.2 SAFETY DURING INSTALLATION

1	After doing a layout of all footings and before digging footing holes, be sure to inquire about underground utilities that may exist. Call 811, a new federally-mandated national "Call Before You Dig" phone number.
2	Do not leave the job site unattended without making sure that all fastening hardware on all main structures and components are tightened. We also suggest roping off construction areas, and covering all holes that do not have a piece of equipment in them with plywood or other suitable material. Because ready or not, children will use unattended equipment.
3	Due to the weight involved with the structure you have purchased, it is advisable that a party of four to six persons of average build assemble the structure.

General safety recommendations applicable to the installation and maintenance of play equipment supplied by Krauss Craft, Inc.

R5 - 04.1 USE ZONES

Use zones are the areas under and all around each piece of play equipment that must be covered by an acceptable impact absorbing surface material as described above.

The specific size of these use zones depends on the type of play equipment as follows:

R5 - 04.1.1 SLIDES

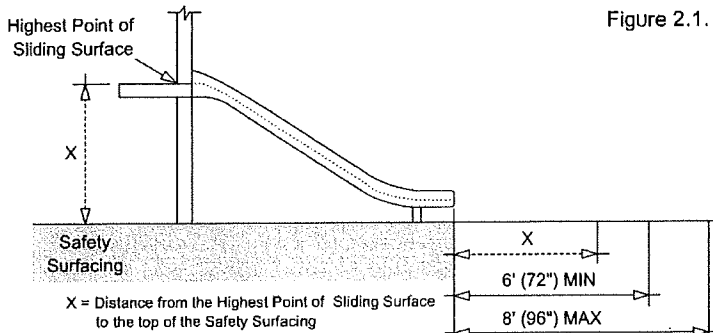

The minimum lower exit end use zone for slide exits is determined as follows:
 X = The distance from Highest Point of the slide surface to the Safety Surfacing.
 If X is less than 72 in. then the exit use zone for that slide shall be a minimum of 72 in. otherwise the minimum exit use zone shall be the distance X, not exceeding the maximum of 96 in.
 (Refer to Figure 2.1 at left)

IMPORTANT: No other play structure use zone shall overlap the lower exit end use zone of a slide. (Refer to the ASTM F1487, Section 9.6)

R5 - 04.1.2 BELT SWINGS (To-Fro Swings)

The use zone must extend at least twice the distance from the pivot point to the safety surface. The use zone must also extend for a minimum of 72 in. out from each end of the swing frame legs. No other play structure use zone shall overlap the front to rear swing use zone. (Refer to the ASTM F1487, Section 9.4.1)

Please refer to the ASTM guidelines for additional information on swings.

R5 - 04.1.3 TIRE SWINGS (Rotating Swings)

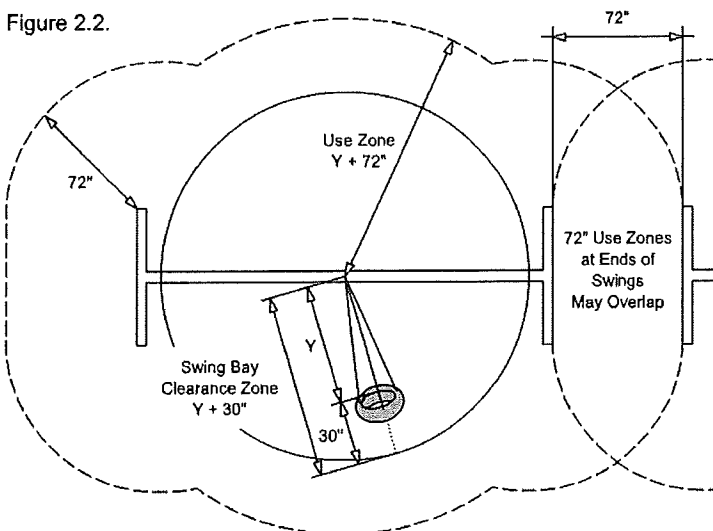

The minimum use zone for rotating swings is determined as follows:
 Y = The vertical distance from the top of the Sitting Surface to the Pivot Point.
 The minimum use zone of a rotating swing (Ex. a Tire Swing) is determined by taking the distance Y and adding to it 72 in. in all directions. The use zone must also extend for a minimum of 72 in. out of each end from the swing frame legs. The 72 in. use zones at the ends of all swings may overlap. (Refer to Figure 2.2 at left)

IMPORTANT: No other play structure use zone shall overlap the swing bay clearance zone of a slide. The rotating swing requires a 108 in. use zone between the rotating swing support structure and all non-swing play structures. (Refer to the ASTM F1487, Section 9.4.2)

R5 - 04.1.4 ALL OTHER PLAY EQUIPMENT

Stationary and rotating play equipment use zones must extend at least 72 in. in all directions from the equipment's perimeter. Rocking/Springing equipment intended for standing, use zones must extend at least 84 in. in all directions from the equipment's perimeter with no other use zones overlapping it.

GENERAL SAFETY RECOMMENDATIONS

R5 - 04.2

R5 - 04.2.1 SURFACES

All play equipment must be installed over an acceptable impact absorbing surfacing material. It is the responsibility of the playground designer, installer and operator to ensure that the size, type and depth of impact absorbing material used complies with the CPSC Handbook. This impact absorbing surface material must cover the entire "Use Zone" area to a depth appropriate for the height of play equipment. See the "Use Zones" section for specific dimensions for specific types of play equipment. Please refer to the CPSC "Handbook for Public Playground Safety", Publication 325 at www.cpsc.gov for more detailed information regarding these issues.

ACCEPTABLE	<p>Unitary Safety Surfacing: Pour-in-place rubber or rubber tile.</p> <p>Loose Fill materials: Bark nuggets, Wood Mulch, Wood Chips, Pea Gravel and Sand. For the Loose Fill Materials listed, Krauss Craft recommends a minimum uncompressed depth of 12 in. (9 in. compacted) for equipment with fall heights up to 72 in.</p>
UNACCEPTABLE	Turf, Undisturbed Natural Ground, Undisturbed Compacted Sand, Decomposed Granite, Asphalt, Concrete or any other hard surface.

R5 - 04.2.2 OTHER IMPORTANT ITEMS

During the installation and maintenance process, ensure that:

- WARNING:** Contact burn injuries can occur when metal play surfaces are located in direct sun. To avoid the risk of such burn injuries the United States Consumer Product Safety Commission recommends in it's handbook for public playground safety that metal play surfaces, such as stainless steel slides and bare or painted metal crawl tubes should be located and installed in shaded areas and out of direct sunlight. The proper location of metal play surfaces must be addressed during the play area planning process.
- There are no exposed concrete footings to trip over or fall on. The top of all footings must be at or below the bottom of the layer of impact absorbing material.
- All bolt threads protruding beyond the nut are cut and de-burred until end is smooth to the touch. Sharp edges and/or points of any kind must be eliminated. No more than two threads must be exposed beyond the end of the nut.
- All bolts, screws, set screws, or other fasteners are tightened securely missing bolts, set screws or other fasteners must be replaced immediately.

R5 - 04.2.3 PLAYGROUND LAYOUT EXAMPLE

Figure 4.2

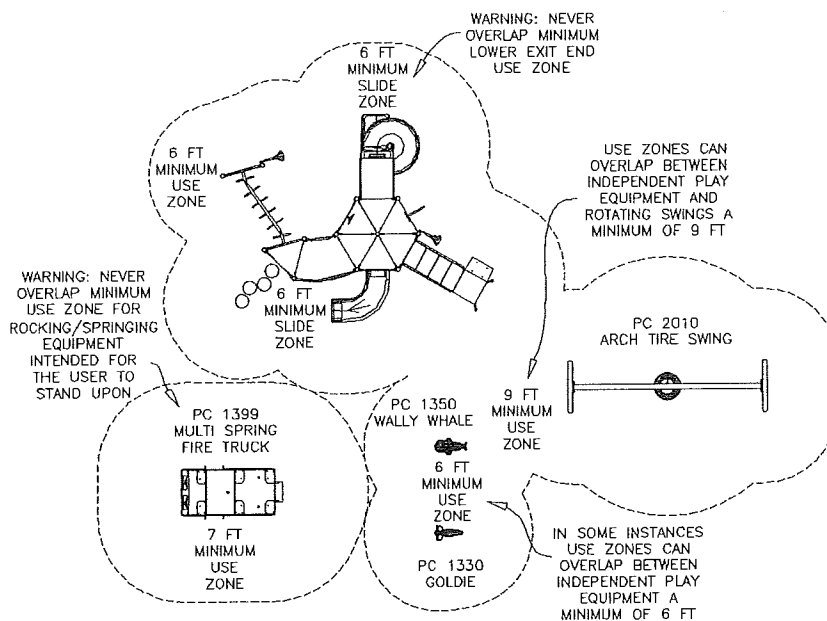

WARNING: No other play structure use zone shall overlap the lower exit end use zone of a slide or the front to rear use zone of a swing.

In most instances, the use zone at the end of a swing can overlap with other play equipment use zones.

Please refer to the ASTM Guidelines For additional information.

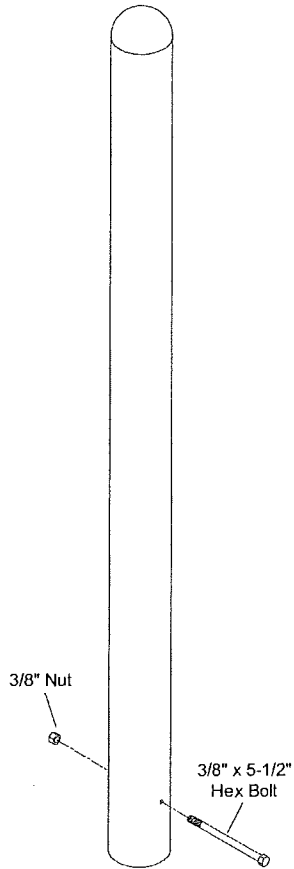

FOOTING PIN
 *Insert bolt as shown above
 in hole near base of posts.



6mm
Washer



3/8" x 1/2"
Socket
Set Screw



1/4" x 1-1/4"
HWH
Tek Screw



1/4" x 1"
Socket Hd.
Cap Screw

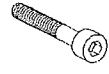

1/4" x 1-3/8"
Socket Hd.
Cap Screw

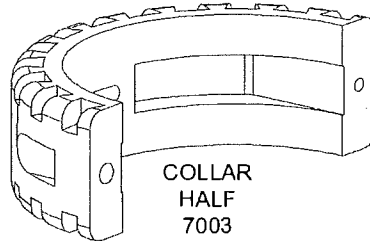

COLLAR
HALF
7003

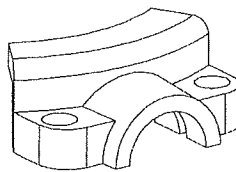

SOCKET
CLAMP
TOP
7004

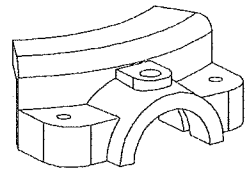

SOCKET
CLAMP
BOTTOM
7005

Thru hole
w/counterbore

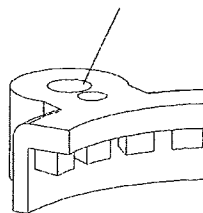

MOUNTING
BLOCK
7006-T

Blind hole
tapped 1/4"-20

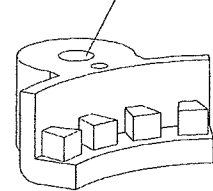

MOUNTING
BLOCK
7006-B

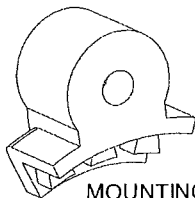

MOUNTING
BLOCK "A"
7006A

NOTE: **Only** used
for R5 Deck 5
(2) 45° Corners
(Half Deck)

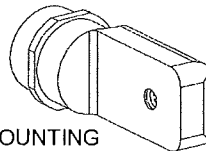

MOUNTING
LUG
7007

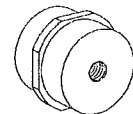

MOUNTING
INSERT
7015

Figure 5.1

CONCRETE FOOTINGS

R5 - 06.1

IMPORTANT: The footing depth for support posts and other equipment must be adjusted to compensate for the depth/thickness requirements of the selected impact attenuating safety surface. (i.e. wood chips vs. rubber matting).

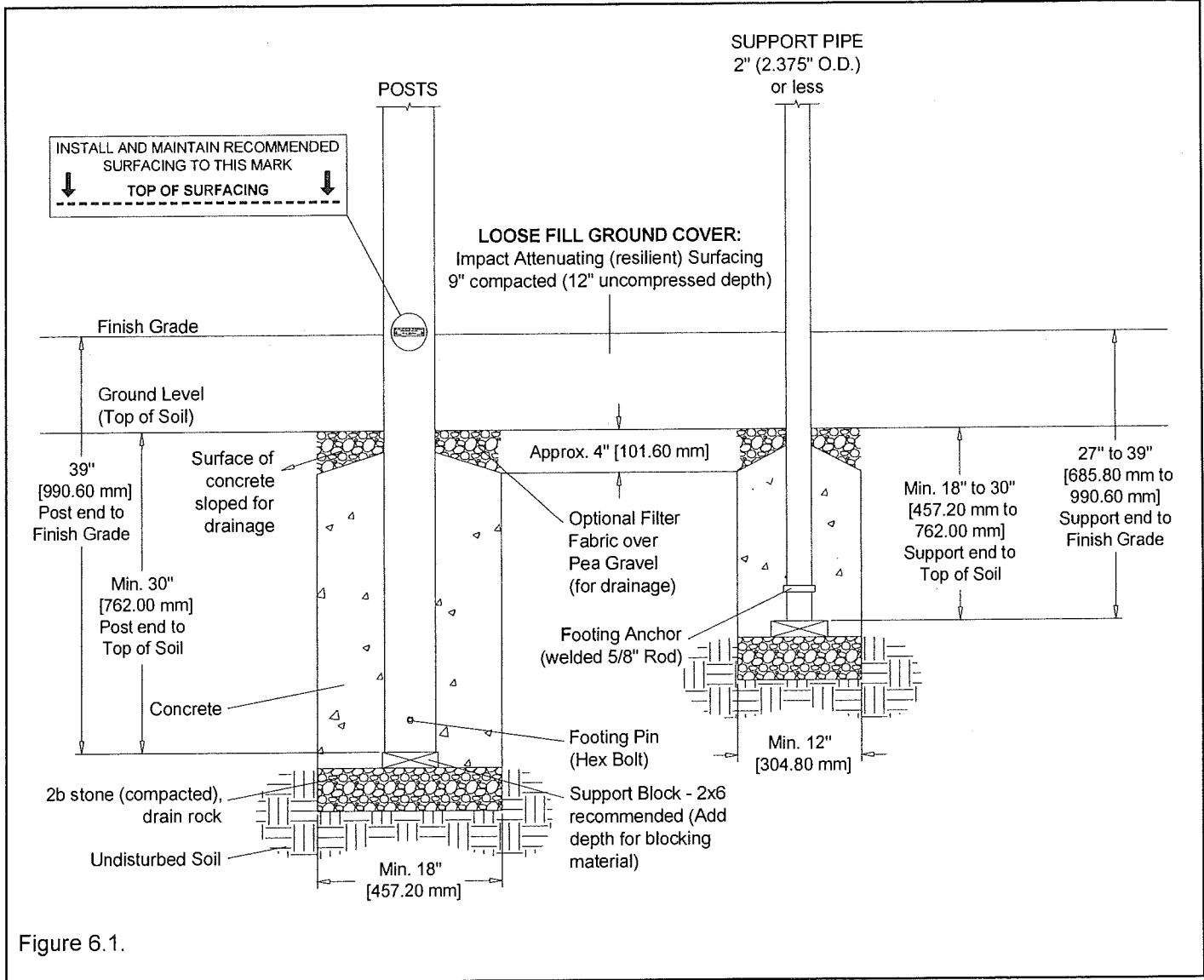

Figure 6.1.

R5 - 06.1 IMPORTANT:

1	Use more concrete as required for supporting activities with movement such as the Track Rides, Traverses, Chinning Bars and Swings.
2	See specific Swing Assembly Instructions for swing post footings and ground cover requirements.
3	Larger footings (more concrete) may also be required due to weather conditions and poor unstable, loose or granitic soil. Before changing footing dimensions we recommend that the footings be reviewed and approved by a registered Engineer.
4	Base of the footing must be below the frost line. Determine depth of frost line for your area and adjust footing depth (not post and support depth) as required.

R5 - 06.1 IMPORTANT: (notes continued)

5	Krauss Craft, Inc. recommends a loose fill material such as engineered wood fiber (as described in the C.P.S.C.) be installed at a depth of no less than 12 in. to allow for natural shrinkage, and compression during use. A minimum 9 in. depth of compressed loose fill material described above is required for equipment with fall heights up to 6 ft. Comparison of impact attenuating surfacing is available in the Playcraft Surfacing Technical Information Guide published by (C.P.S.C).
6	Never install loose fill material over concrete or asphalt.
7	The depth of the post/support must be adjusted to compensate for the depth of impact attenuating surfacing material ranging from loose fill material to rubber matting.
8	This equipment is designed to be installed on a level site. The soil should be compacted or undisturbed. The footings must be cast against undisturbed soil. Support posts and all attached decks and play components must be plumb and level.

**For more information, refer to the current publication of the USCPSC
"Handbook for Public Safety"**

For a copy, write to:
U.S. Consumer Product Safety Commission
 Office of Information and Public Affairs
 Washington, D.C. 20207
 Or call
Toll-Free: 1-800-638-2772
Website: www.cpsc.gov

R5 - 06.2 INSTALLATION

Step 1	In order to properly install the support posts on your play structure, refer to the General Safety Recommendations in section R5 – 04.1 & 04.2 as well as the Top View and/or Site Plan drawings found in the Construction Drawings section R5 - 02. Please be sure to read the General Safety Guidelines before proceeding with Step 2.
Step 2	With the support block at the base of the footing hole, place the support post in the footing hole at the determined depth. The support block helps to stabilize the post during assembly and while the concrete cures, especially in soft soil conditions.
Step 3	Plumb and square all support posts. Block and brace as required to prepare for final assembly and pouring of concrete.
Step 4	Do not pour concrete until the structure is completely assembled, leveled and plumbed. Concrete must be allowed to cure completely before using the structure (at least 72 hours).

SAFETY / WARNING LABELS

R5 - 07

R5 - 07.1 CHILDREN'S SAFETY PRECAUTIONS - PLEASE READ CAREFULLY

1	Children at play must be in view of a supervising adult on-site at all times.
2	Warn children not to climb or walk on top of playground equipment (framework) not intended for such use.
3	All play equipment should be used in the manner it was intended. Children should not swing empty seats or twist ropes and swing chains.
4	Children should be dressed appropriately. Avoid loose fitting clothing such as scarves, ponchos, and clothing that could become easily entangled on equipment.
5	Children should be cautioned to avoid walking too closely, between, or in front of moving items.
6	Only one child per swing should be allowed. Instruct children to sit in the center of the swings with their full weight on the seat.
7	Children being pushed on swing equipment should be closely supervised by an adult. It is important to note that an aggressive push could result in a child losing his/her balance.
8	Children should be instructed not to jump off swing equipment when in motion.
9	No more than 3 children should be riding on the tire swing at one time.
10	Children should not be pushed while on the tire swing.
11	Children should be advised to "wait their turn" on activities such as a slide therefore, each child is able to slide down and safely move to the side before another child begins their descent.
12	Children's personal toys (bikes, wagons, etc.) should be stored away from the play structure area.

R5 - 07.2 WARNING LABEL ATTACHMENT

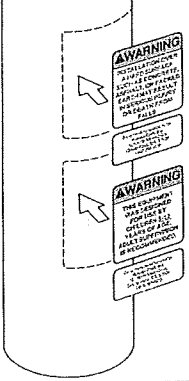
1	<p>Large structures may require two or more sets of Warning Labels. For additional Warning Labels, call (800) 333-8519.</p> <p>Standard set includes (1) Hard Surface warning label and (1) Designed for Ages (2-5, 5-12 or 2-12) warning label.</p>	
2	Attach in a conspicuous location, such as near an entry.	
3	To apply, clean post with alcohol, remove protective backing and apply to clean post.	

R5 - 07.3 SURFACING LEVEL LABEL ATTACHMENT

1	<p>Some play equipment may require recommended surfacing level labels appropriately placed at the bottom of all posts. The correct placement of the labels is dependent on the requirements of the specific equipment design and resilient ground cover choice. Please consult with your Playcraft representative or call the factory at (800) 333-8519 for surfacing and label placement advice.</p>	<div style="border: 1px solid black; padding: 5px; margin: 10px auto; width: 80%;"> <p style="text-align: center; font-size: small;">INSTALL AND MAINTAIN RECOMMENDED SURFACING TO THIS MARK</p> <p style="text-align: center; font-weight: bold;">↓ TOP OF SURFACING ↓</p> <p style="text-align: center;">-----</p> </div>
2	To apply, clean post with alcohol, remove protective backing and apply to clean post.	

To ensure the safest play area and equipment possible, periodic inspections should be performed and recorded on a daily, weekly and monthly basis. Some form of maintenance program should be established and strictly adhered to.

Note: A comprehensive list of maintenance steps, including a sample playground maintenance safety inspection form, can be found in the complete maintenance manual included with your purchase.

R5 – 08.1 Your maintenance program should include at minimum, the following general maintenance steps:

1	Appropriate impact attenuating safety surface material must be maintained under and around all playground equipment.
2	The equipment and play area must be kept clean and free of any miscellaneous debris or litter.
3	Moving parts such as ropes, chains, swing hangers, bridges, etc. must be inspected regularly to determine if excessive wear is occurring. Any parts showing excessive wear or damage must be replaced.
4	All bolts, hardware, collars and fittings must be checked regularly and tightened if necessary.
5	Any broken or missing end caps on pipe must be replaced.
6	Check all Steel and Poly Surfaces and replace or repair as required.
7	Tire swing swivel must be greased at time of installation and on a regular basis. Each swivel is equipped with 1 or 2 grease fittings to allow lubrication with a standard grease gun.
8	Make sure warning labels are legible and in a conspicuous location.

For further information or questions about maintenance or for replacement parts, please contact your Playcraft representative or Krauss Craft, Inc. customer service at 1-800-333-8519.

IMPORTANT NOTES: Read First

- (A) Use liquid thread lock (such as Loctite®) with all threaded hardware. **Important:** Liquid thread lock (prior to curing) helps to eliminate the common problem of "thread seizure" in stainless steel hardware by serving as a lubricant during assembly.
- (B) See component assembly instructions for collar heights and locations.
- (C) The Collar splits should be aligned parallel with deck faces and should always be parallel to the collars of the same component. (See Figure 3)
- (D) **Important:** On overhead event's the collars should be oriented so that the Socket Clamps or Mounting Blocks are installed over the Tek Screw. (See Figure 4)

FIGURE 1
Collar Assembly

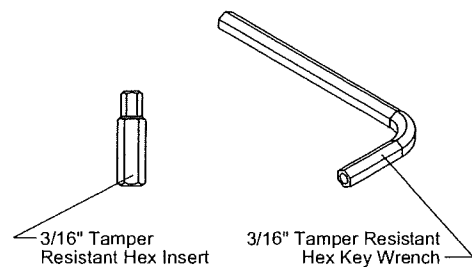
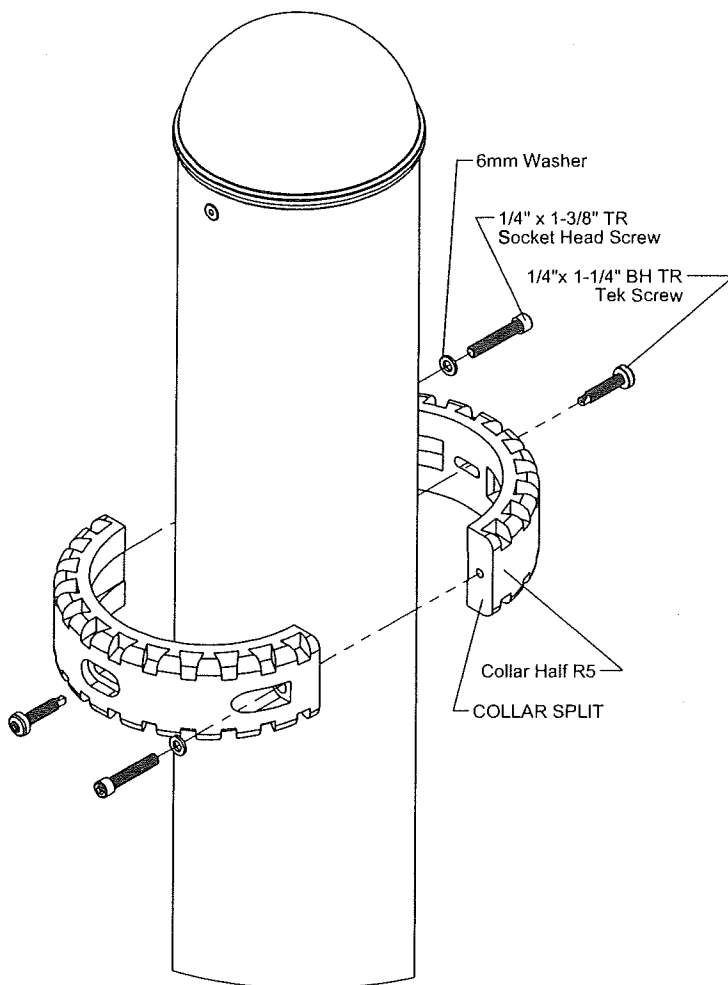

FIGURE 2
Tamper Resistant Tools

Step 1

Locate and mark the position of the collar on the support post, place in the correct position and attach as shown in Figure 1 using the tools shown in Figure 2. (See Figure 3 and 4 and Notes A, B, C and D)

Important: Do not install Tek Screws until the components location and orientation have been established.

Step 2

Check to ensure the placement of the collar assembly is at the specified height and orientation then install the Tek Screws as shown in Figure 1.

Step 3

Fully tighten all fasteners according to the "TIGHTENING TORQUE FOR HARDWARE" section of the Installation Manual. (See Note A)

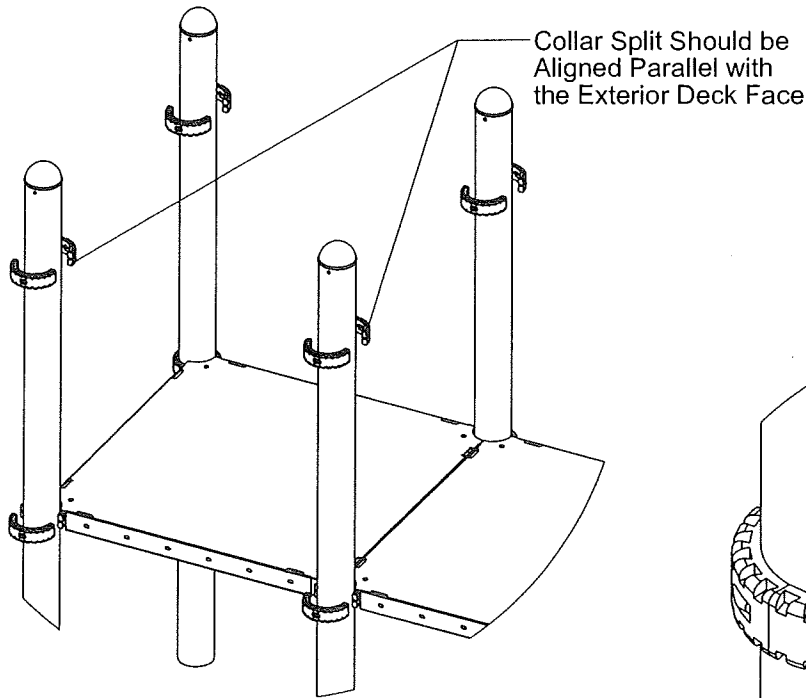

FIGURE 3
Collar Alignment

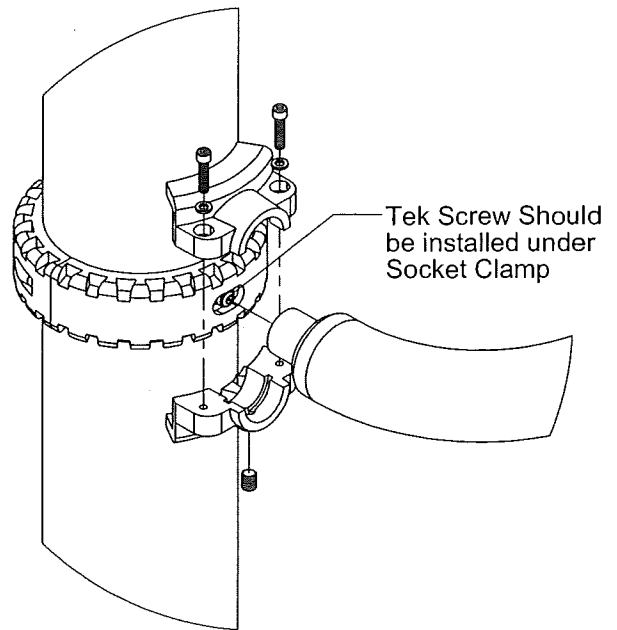

FIGURE 4
Overhead Event Collar Alignment

Specifications

COLLARS:

Shall be two-part and precision die-cast from a high strength aluminum alloy. The Collars have a multi-stage baked-on powder coat finish.

HARDWARE:

Shall be stainless steel, zinc/nickel plated or galvanized as required to resist rust and corrosion.

Parts List

Part #	DESCRIPTION	QTY.
007003	Collar Half R5	2
9271062-TR	Screw Tek 1/4" x 1-1/4" BH TR	2
9281062-5-TR	Screw Soc HD CS 1/4" x 1-3/8" TR	2
9333602	Washer Flat 6 mm	2

Maintenance

Periodically tighten all screws, bolts and nuts. A periodic inspection of all parts is necessary. If a part is broken or worn, replace immediately. For general maintenance please refer to our Playground Maintenance Manual.

TYPE 1 - Mounting Block (Applies to most decks)

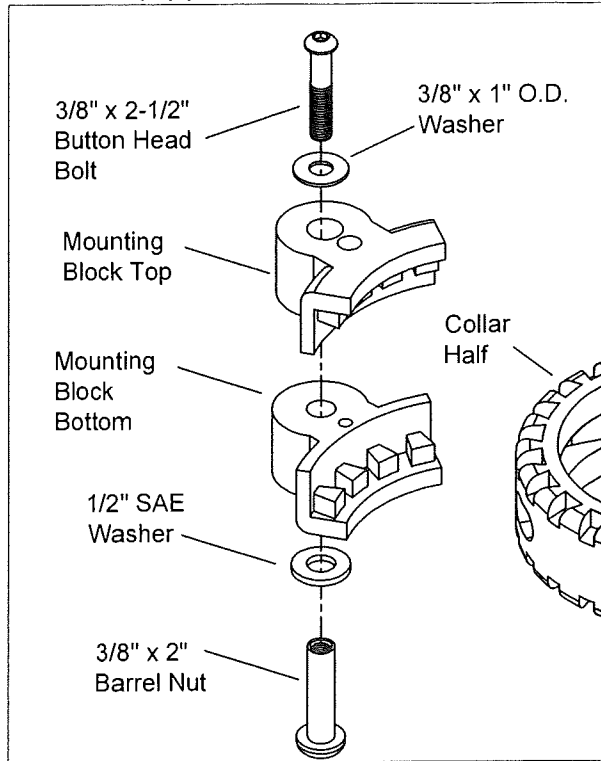

TYPE 2 - Mounting Block & Clevis (Applies to most traverses and bridge walls)

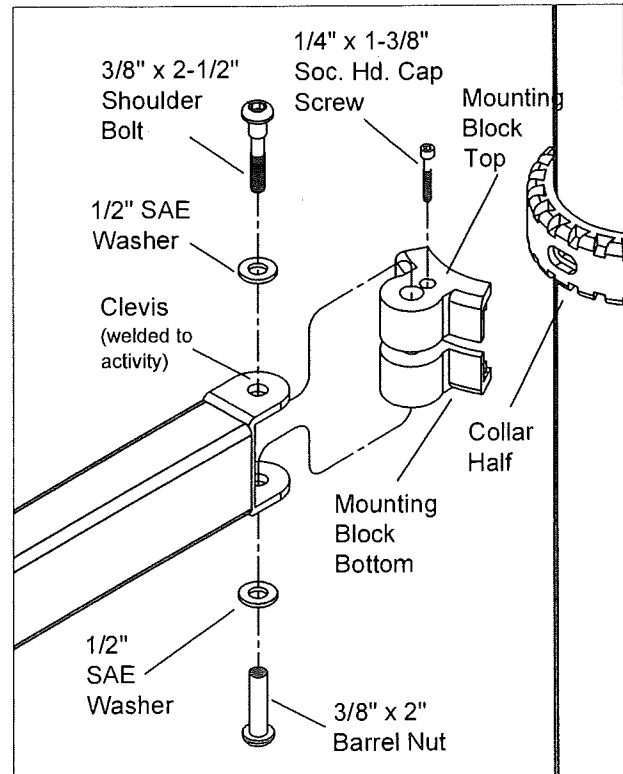

TYPE 3 - Mounting Block A (Applies to R5 Deck #5 only)

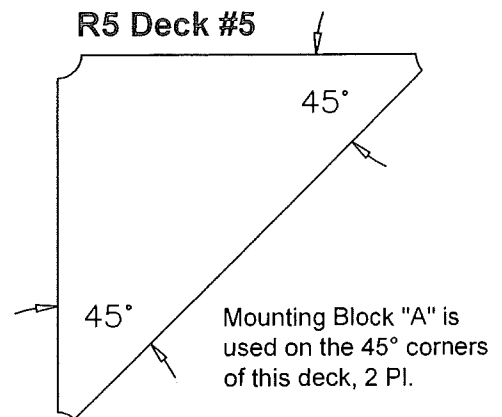
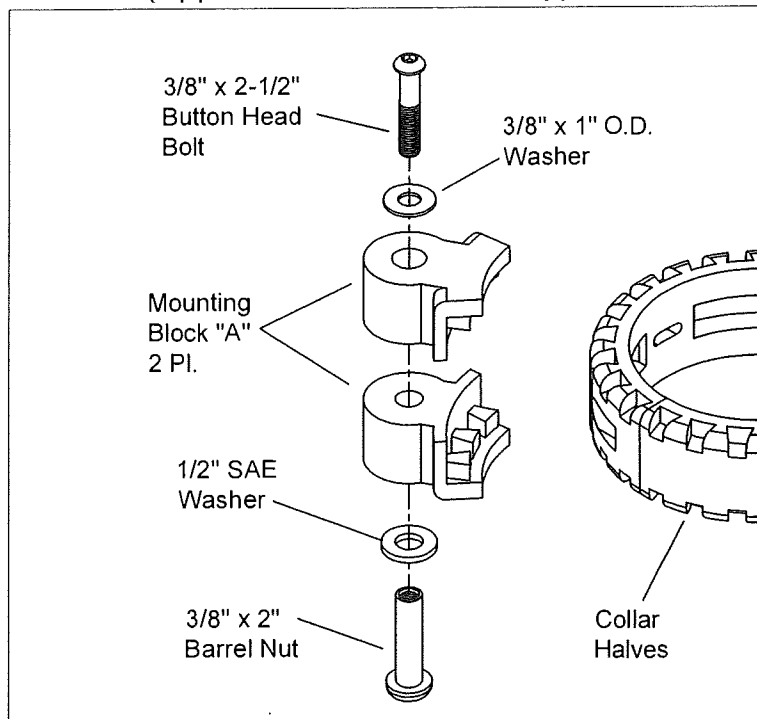

Parts List - Type 1

<u>PART #</u>	<u>DESCRIPTION</u>	<u>QTY.</u>
007006-B	Mounting Block R5 Bottom	1
007006-T	Mounting Block R5 Top	1
9103112-TR	Bolt Button Head 3/8" x 2-1/2"	1
9333002	Washer Flat 3/8" x 1" x .100" thick	1
9345002	Washer Flat SAE 1/2"	1
9443092-TR	Nut Barrel 3/8" x 2" BH	1

Parts List - Type 2

<u>PART #</u>	<u>DESCRIPTION</u>	<u>QTY.</u>
007006-B	Mounting Block R5 Bottom	1
007006-T	Mounting Block R5 Top	1
9143112-TR	Bolt Shoulder 3/8" x 2-1/2"	1
9281062-5	Screw Soc HD CS 1/4" x 1-3/8"	1
9345002	Washer Flat SAE 1/2"	2
9443092-TR	Nut Barrel 3/8" x 2" BH	1

Parts List - Type 3

<u>PART #</u>	<u>DESCRIPTION</u>	<u>QTY.</u>
007006A	Mounting Block A	2
9103112-TR	Bolt Button Head 3/8" x 2-1/2"	1
9333002	Washer Flat 3/8" x 1" x .100" thick	1
9345002	Washer Flat SAE 1/2"	1
9443092-TR	Nut Barrel 3/8" x 2" BH	1

Installation

NOTES: More detailed instructions will be supplied with the specific components being installed on your play system.

Step 1.

Attach Collar halves to post. Refer to Collar Assembly Page R5 - 09.

Step 2.

Attach Mounting Blocks to Collar and activity to Mounting Blocks using type (1-3) hardware as specified.

Step 3.

Snug tighten all fasteners.

Step 4.

Check to ensure proper placement of the activity.

Step 5.

Apply liquid thread lock and fully tighten all fasteners according to the "TIGHTENING TORQUE FOR HARDWARE" Section of the Installer's Manual.

Specifications

MOUNTING BLOCKS:

Shall be two-part and precision die-cast from a high strength aluminum alloy. The Mounting Blocks have a multi-stage baked-on powder coat finish.

HARDWARE:

Shall be stainless steel, zinc/nickel plated, or galvanized as required to resist corrosion.

Maintenance

Periodically tighten all screws, bolts and nuts. A periodic inspection of all parts is necessary. If a part is broken or worn, replace immediately. For general maintenance please refer to our Playground Maintenance Manual.



Manufactured by Krauss Craft, Inc.
www.playcraftsystems.com

For Customer Service Call
800.333.8519 (U.S.A.) or
541.955.9199 (International)

Rev C

IMPORTANT NOTES: Read First

(A) Use liquid thread lock (such as Loctite®) with all threaded hardware. **Important:** Liquid thread lock (prior to curing) helps to eliminate the common problem of "thread seizure" in stainless steel hardware by serving as a lubricant during assembly.

(B) Refer to Installation Manual for R5-09 Collars.

FIGURE 1
Socket Clamp Assembly

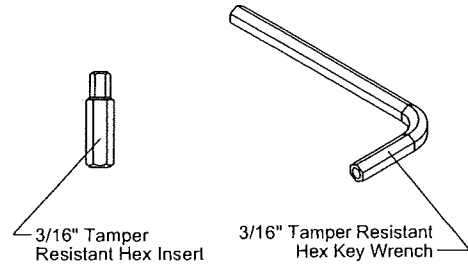
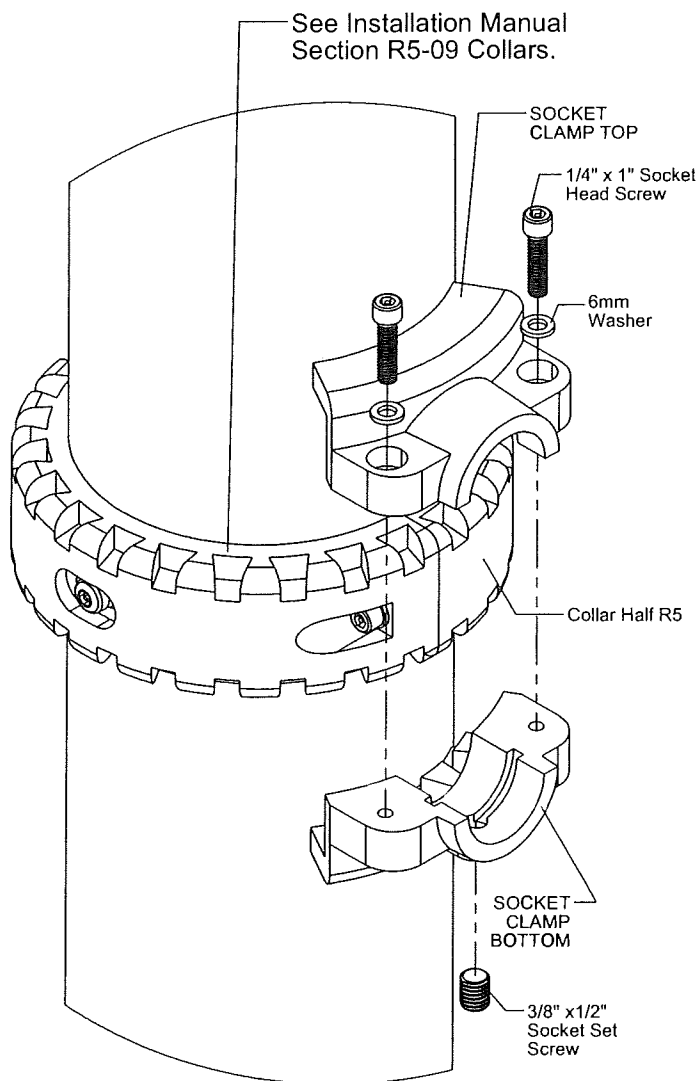

FIGURE 2
Tamper Resistant Tools

Step 1

Attach collar to post. (See Note B)

Step 2

Loosely attach the socket clamps to the collar as shown in Figure 1 using the tools shown in Figure 2. (See Note A and B)

Note: Take care to achieve proper thread engagement of Socket Head Cap Screws to prevent cross threading while drawing upper and lower socket clamp halves together during tightening of hardware.

Step 3

Check the placement of activity and make adjustments if necessary.

Step 4

Fully tighten all fasteners according to the "TIGHTENING TORQUE FOR HARDWARE" section of the Installation Manual.

SOCKET CLAMP ASSEMBLY

R5-11
Page 2 of 2

Specifications

SOCKET CLAMPS:

Shall be two-part and precision die-cast from a high strength aluminum alloy. The Socket Clamps have a multi-stage baked-on powder coat finish.

HARDWARE:

Shall be stainless steel, zinc/nickel plated or galvanized as required to resist rust and corrosion.

Parts List

Part #	DESCRIPTION	QTY.
007004	Socket Clamp Top R5	1
007005	Socket Clamp Bottom R5	1
9263012-TR	Screw Soc Set 3/8" x 1/2"	1
9281052-TR	Screw Soc HD 1/4" x 1"	2
9333602	Washer Flat 6 mm	2

Maintenance

Periodically tighten all screws, bolts and nuts. A periodic inspection of all parts is necessary. If a part is broken or worn, replace immediately. For general maintenance please refer to our Playground Maintenance Manual.



Manufactured by Krauss Craft, Inc.
www.playcraftsystems.com

For Customer Service Call
800.333.8519 (U.S.A.) or
541.955.9199 (International)

Rev E
3/13/2009

Mounting Lug Application - Steel

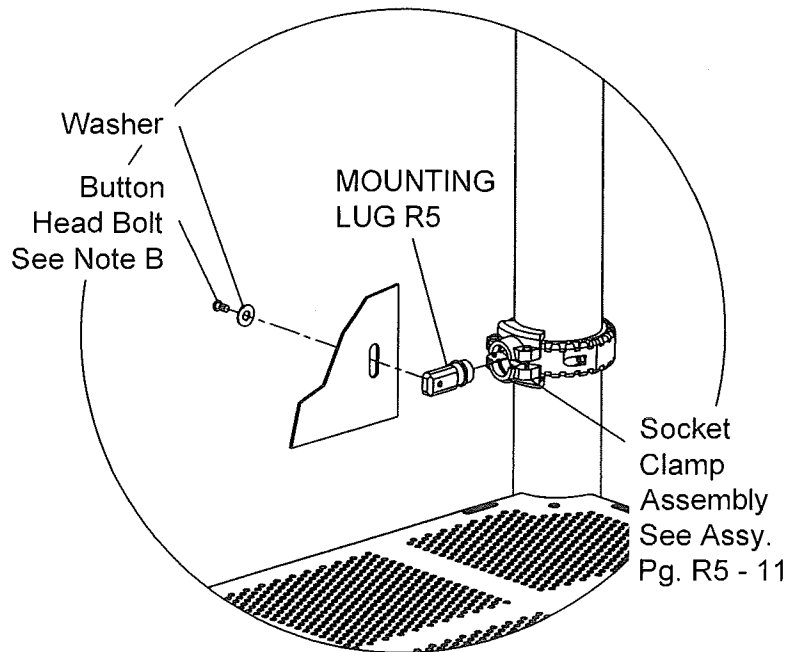

Mounting Lug Application - HDPE

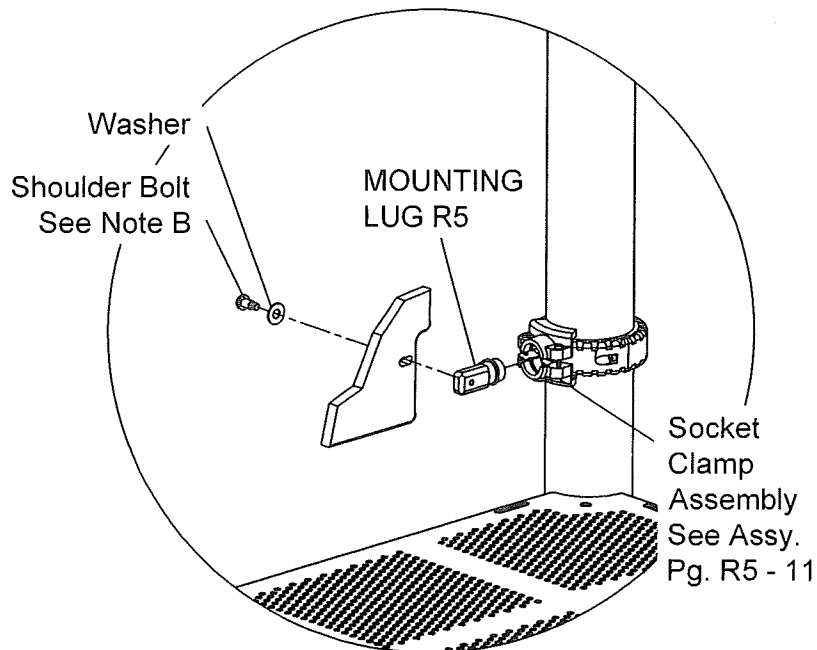

Parts List

<u>PART #</u>	<u>DESCRIPTION</u>	<u>QTY.</u>
007007	Mounting Lug R5	1

Installation

Notes:

A) More detailed instructions will be supplied with the specific components being installed on your play system.

B) Note that the length of the Button Head Bolt or Shoulder Bolt varies depending upon the application.

Step 1.

Attach Collar halves to Post. Refer to Collar Assembly Page R5 - 09.

Step 2.

Attach Socket Clamp Assembly to Collar. Refer to Socket Clamp Assembly Page R5 - 11.

Step 3.

Attach the activity to the Mounting Lug using the hardware as specified for the specific application.

Step 4.

Snug tighten all fasteners.

Step 5.

Check to ensure proper placement of the activity and make adjustments if necessary.

Step 6.

Apply liquid thread lock and fully tighten all fasteners according to the "TIGHTENING TORQUE FOR HARDWARE" Section of the Installer's Manual.

Specifications

MOUNTING LUG:

Shall be precision die-cast from a high strength aluminum alloy. The Mounting Lug has a multi-stage baked-on powder coat finish.

Maintenance

Periodically tighten all screws, bolts and nuts. A periodic inspection of all parts is necessary. If a part is broken or worn, replace immediately. For general maintenance please refer to our Playground Maintenance Manual.



Manufactured by Krauss Craft, Inc.
www.playcraftsystems.com

For Customer Service Call
800.333.8519 (U.S.A.) or
541.955.9199 (International)

Rev B

Mounting Insert Application

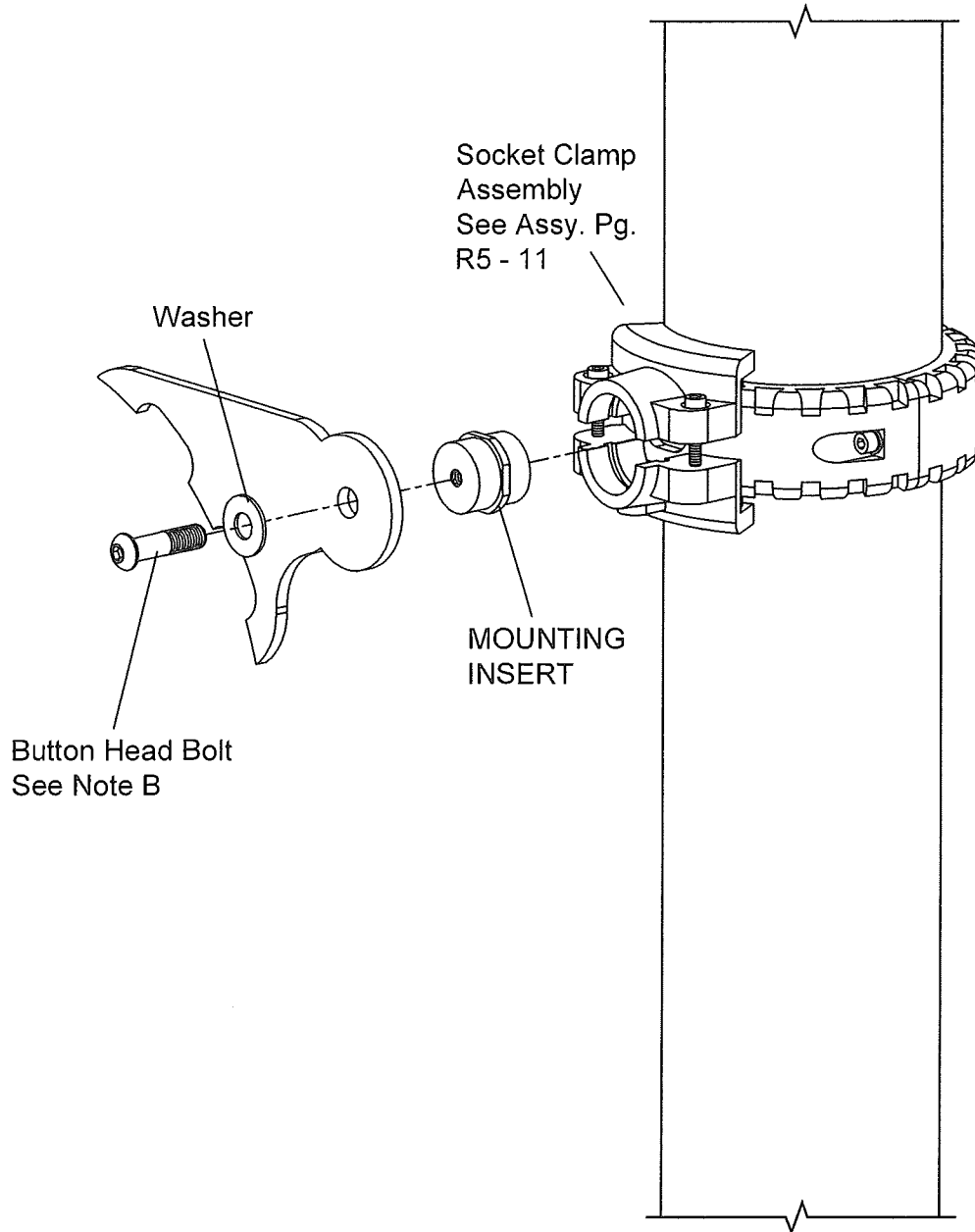

Parts List

<u>PART #</u>	<u>DESCRIPTION</u>	<u>QTY.</u>
007015	Mounting Insert	1

Installation

Notes:

A) More detailed instructions will be supplied with the specific components being installed on your play system.

B) Note that the length of the Button Head Bolt varies depending upon the application.

Step 1.

Attach Collar halves to Post. Refer to Collar Assembly Page R5 - 09.

Step 2.

Attach Socket Clamps to Collar. Refer to Socket Clamp Assembly Page R5 - 11

Step 3.

Attach the activity to the using the Mounting Insert and hardware as specified for the specific application.

Step 4.

Snug tighten all fasteners.

Step 5.

Check to ensure proper placement of the activity and make adjustments if necessary.

Step 6.

Apply liquid thread lock and fully tighten all fasteners according to the "TIGHTENING TORQUE FOR HARDWARE" Section of the Installer's Manual.

Specifications

MOUNTING INSERTS:

Shall be precision die-cast from a high strength aluminum alloy.

Maintenance

Periodically tighten all screws, bolts and nuts. A periodic inspection of all parts is necessary. If a part is broken or worn, replace immediately. For general maintenance please refer to our Playground Maintenance Manual.



Manufactured by Krauss Craft, Inc.
www.playcraftsystems.com

For Customer Service Call
800.333.8519 (U.S.A.) or
541.955.9199 (International)

Rev B

DECK IDENTIFICATION

R5-1100
Page 1 of 1

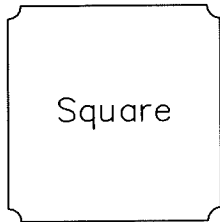

Square

R5 Deck 1

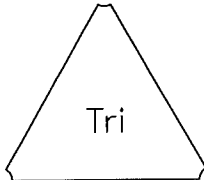

Tri

R5 Deck 2

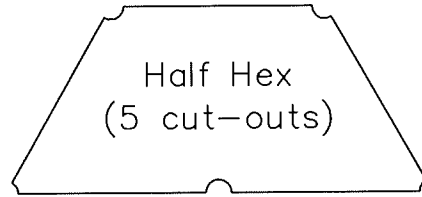

Half Hex
(5 cut-outs)

R5 Deck 4

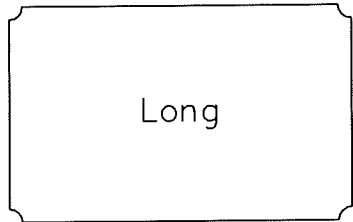

Long

R5 Deck 4

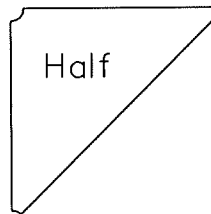

Half

R5 Deck 5

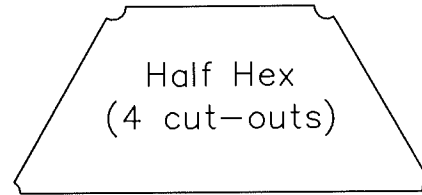

Half Hex
(4 cut-outs)

R5 Deck 6

Note: Most walls
require Decks w/ slots.

Deck With Slots

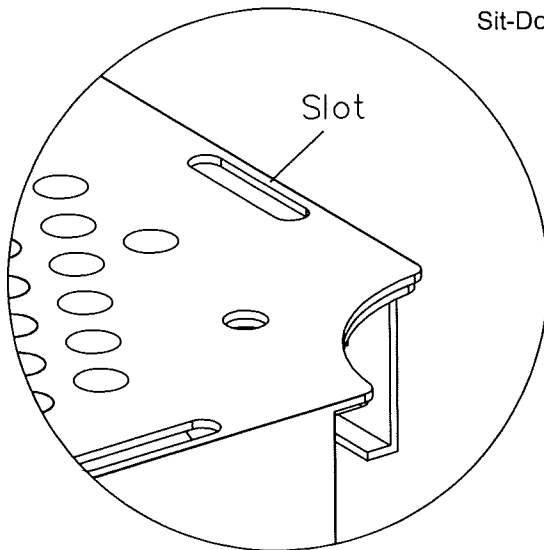

APPLIES TO:
Full Walls
Half Walls
Transition Walls
Sit-Down Walls

Deck Without Slots

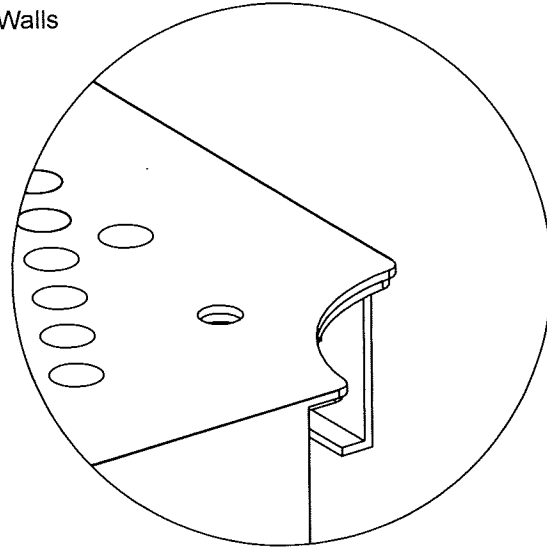

Manufactured by
Krauss Craft, Inc.

Phone: 800.333.8519

Rev. B

DECK R5-1 (Square) ASSEMBLY

R5- 1101
Page 1 of 2

Assembly View

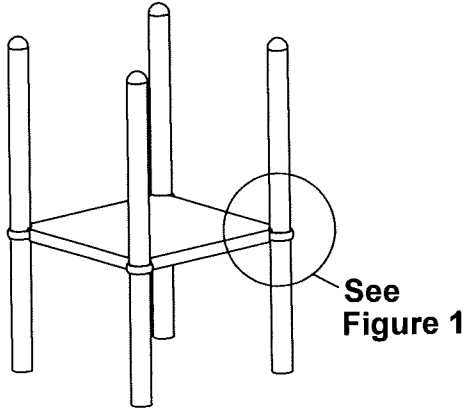

R5 DECK 1

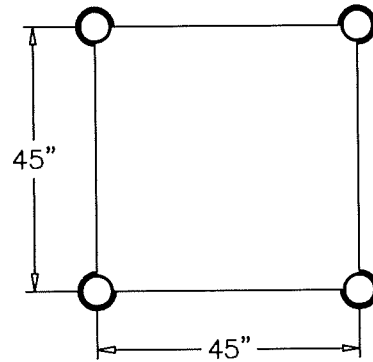
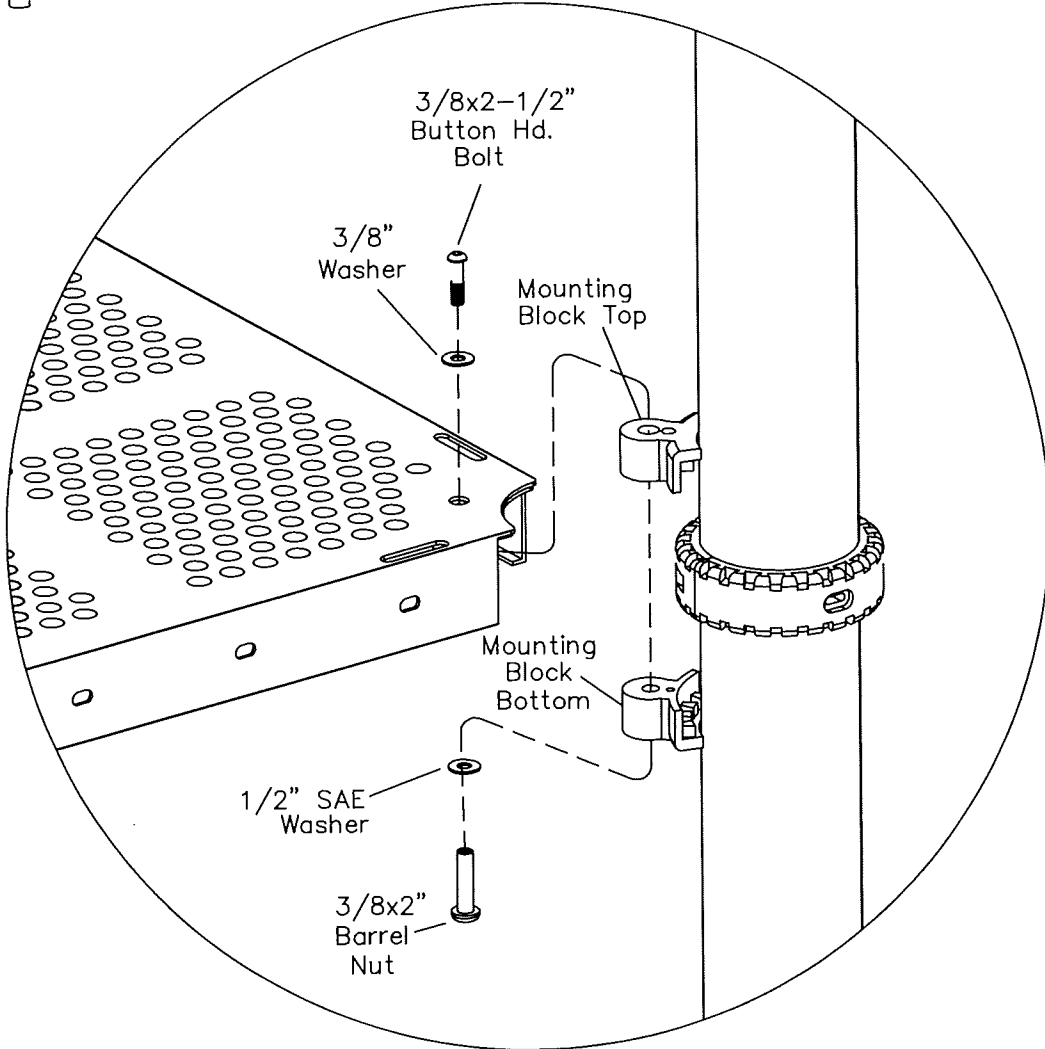

Figure 1



Manufactured by
Krauss Craft, Inc.

Phone: 800.333.8519

Rev. E

Assembly View

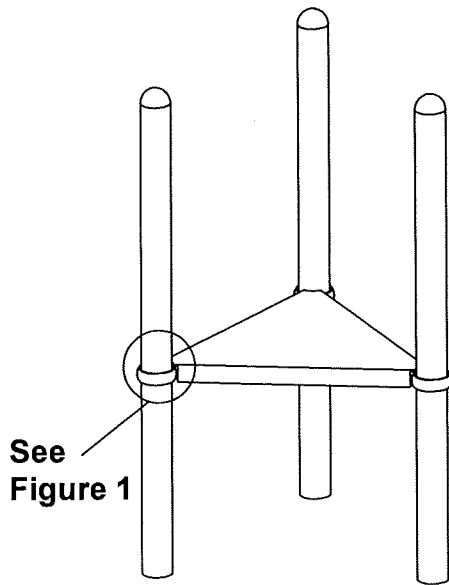

R5 DECK 2

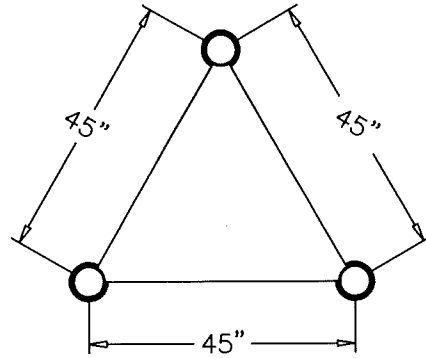
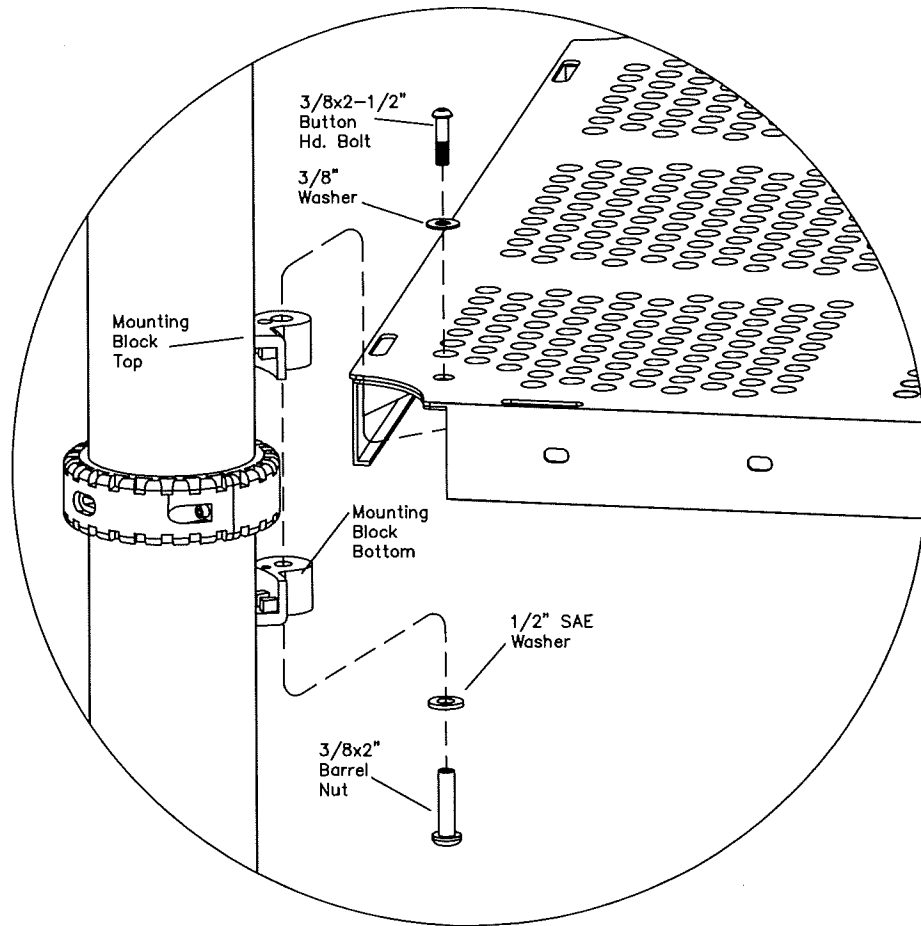
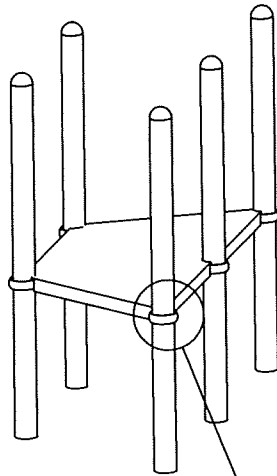

Figure 1



Assembly View



See
Figure 1

R5 DECK 3

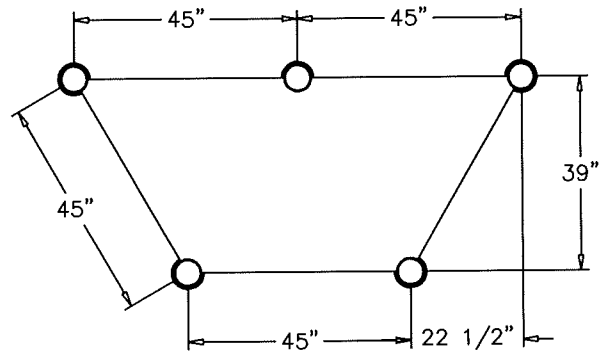
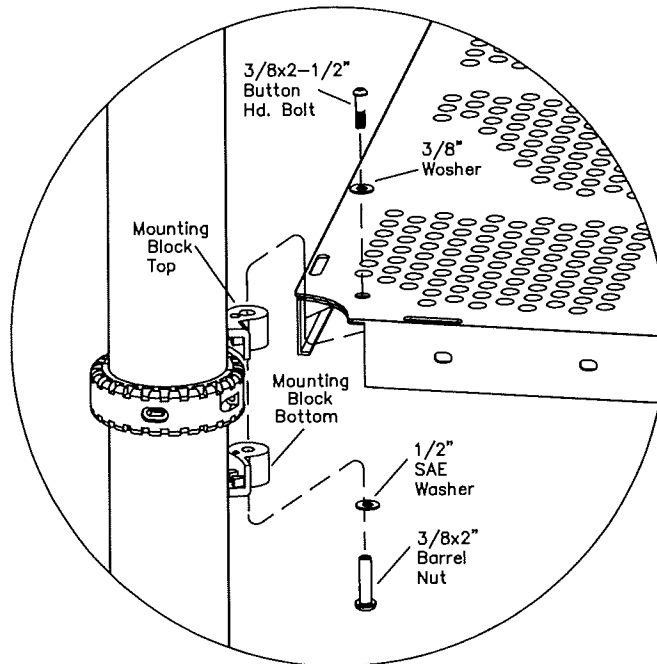

Figure 1



IMPORTANT NOTES: Read First

(A) Use liquid thread lock (such as Loctite®) with all threaded hardware. **Important:** Liquid thread lock (prior to curing) helps to eliminate the common problem of "thread seizure" in stainless steel hardware by serving as a lubricant during assembly.

(B) Fillers must be installed where there is a space between 3-1/2" and 9" to prevent head entrapments.

FIGURE 1
Vertical Deck Filler

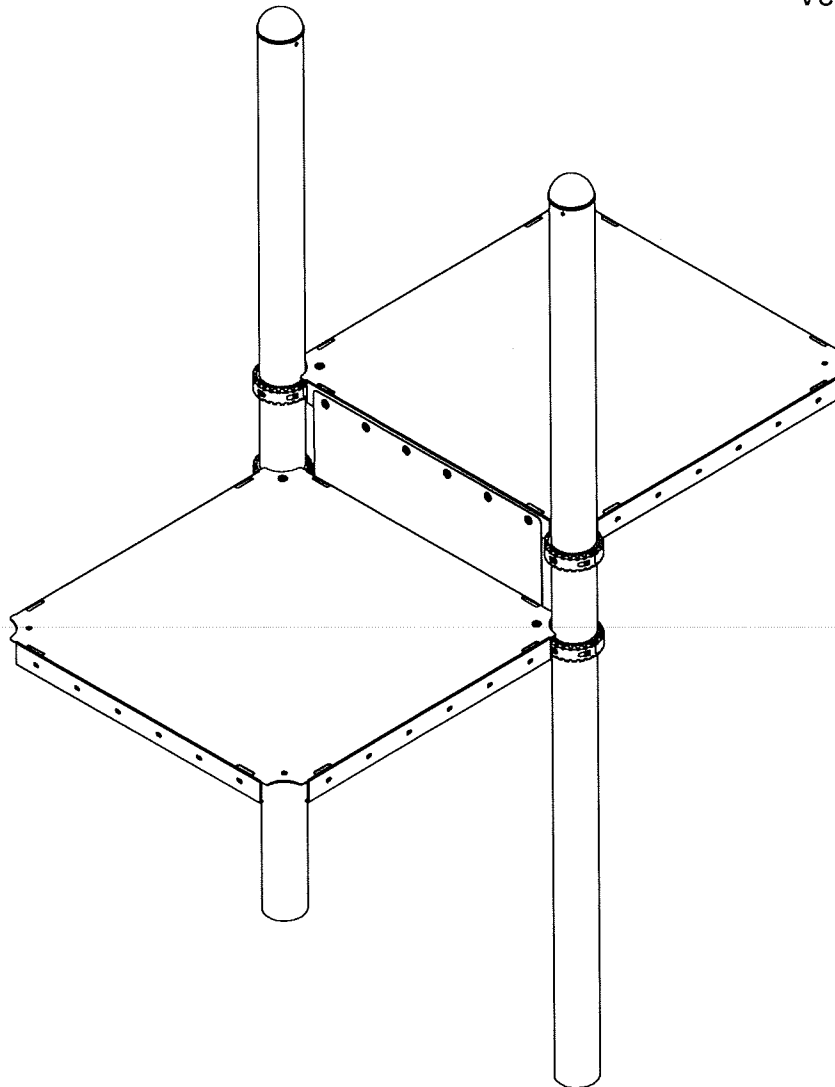

NOTE: 12" Vertical Deck Filler shown on R5 deck assembly. other configurations may vary slightly, but do not affect the assembly.

VERTICAL DECK FILLER

1110-1117

Page 3 of 3

Specifications

VERTICAL DECK FILLERS:

Shall be fabricated from 12 gauge sheet steel. The Vertical Deck Fillers have a multi-stage baked-on powder coat finish.

HARDWARE:

Shall be stainless steel, zinc/nickel plated or galvanized as required to resist rust and corrosion.

Parts List

Part #	DESCRIPTION	QTY.
Varies	Vertical Deck Filler	1
9333002	Washer Flat 3/8" x 1" O.D. x .100" thick	24
9103062-TR	Bolt Button Head 3/8" x 1-1/4"	12
9413002	Nut Lock 3/8"	12

Maintenance

Periodically tighten all screws, bolts and nuts. A periodic inspection of all parts is necessary. If a part is broken or worn, replace immediately. For general maintenance please refer to our Playground Maintenance Manual.



Manufactured by Krauss Craft, Inc.
www.playcraftsystems.com

For Customer Service Call
800.333.8519 (U.S.A.) or
541.955.9199 (International)

Rev E
8/18/2009

Assembly View

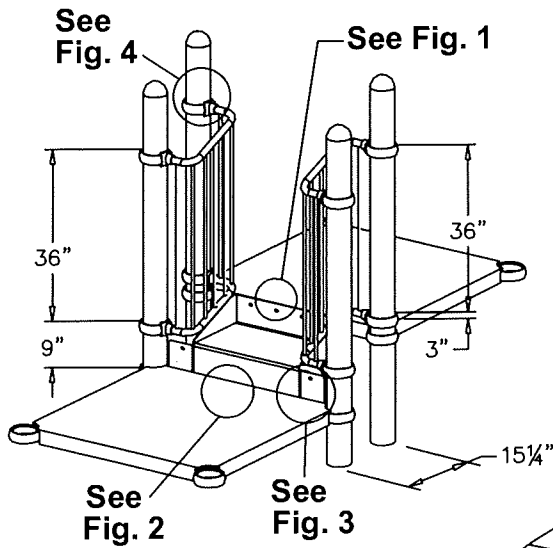

Figure 1

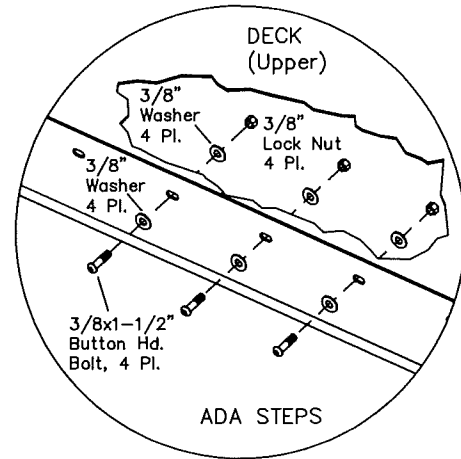

Figure 2

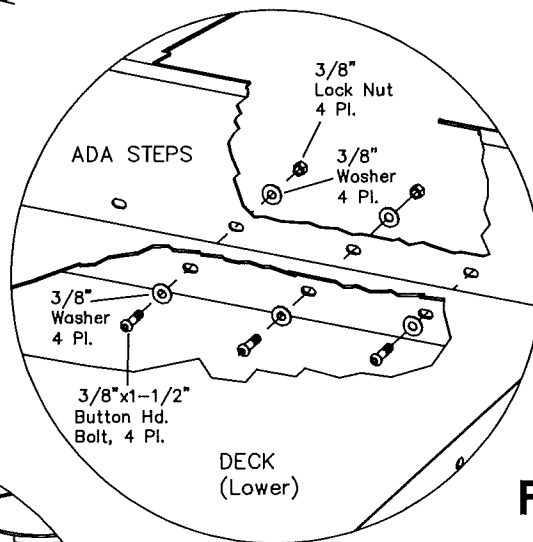

Figure 3 Back View

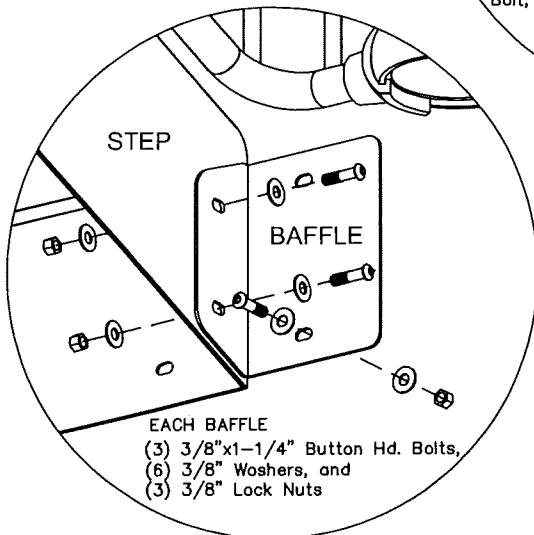

Figure 4

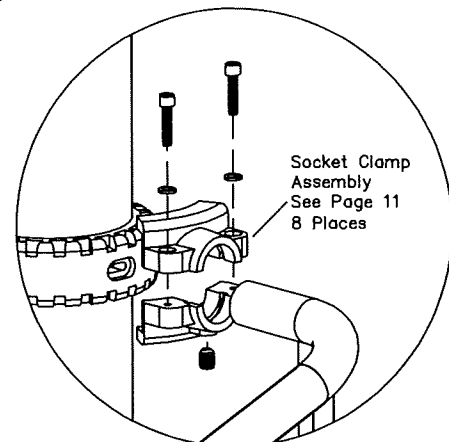
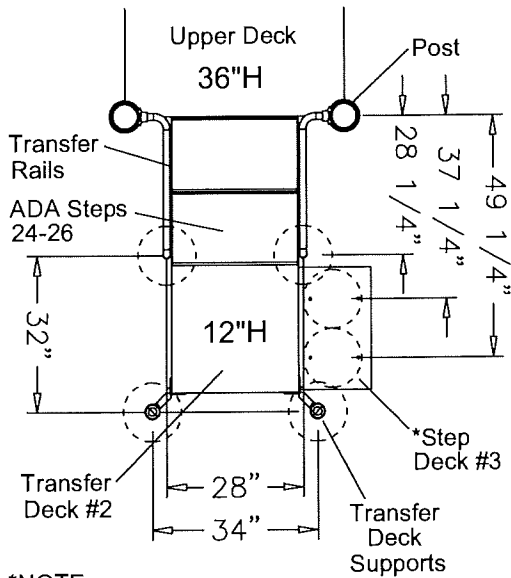

Figure 1 - Top



*NOTE:
Step Deck #3 may be located
on any side of Transfer Deck

Assembly View #1

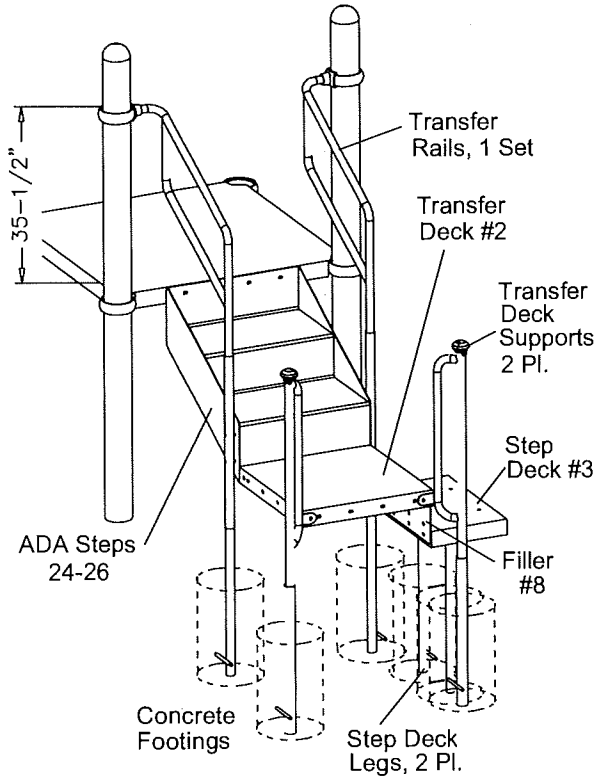

Figure 2

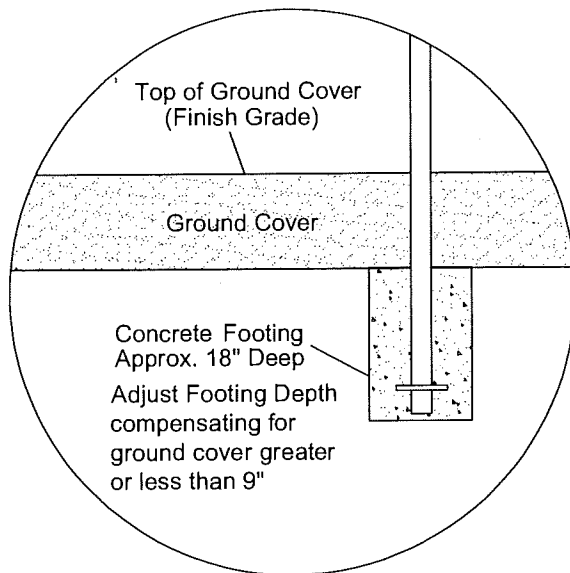
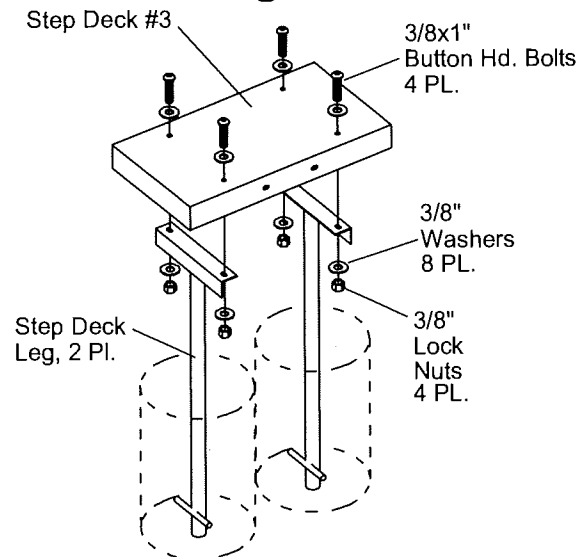

Figure 3



Assembly View #3

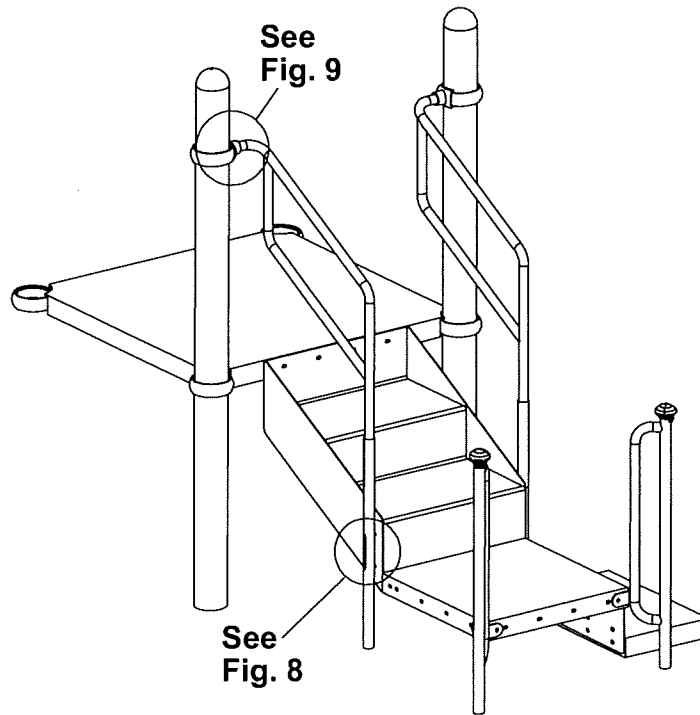

Figure 8

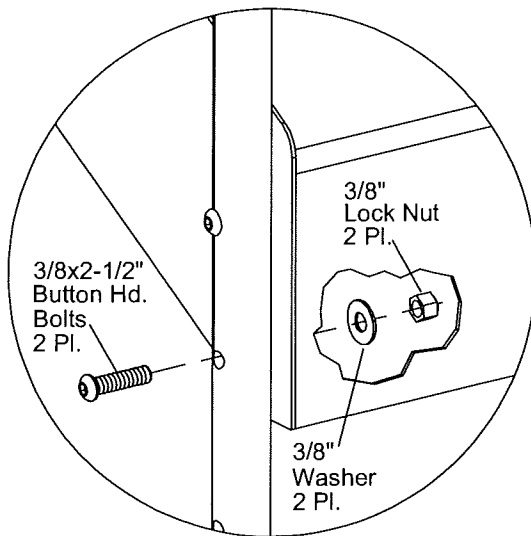
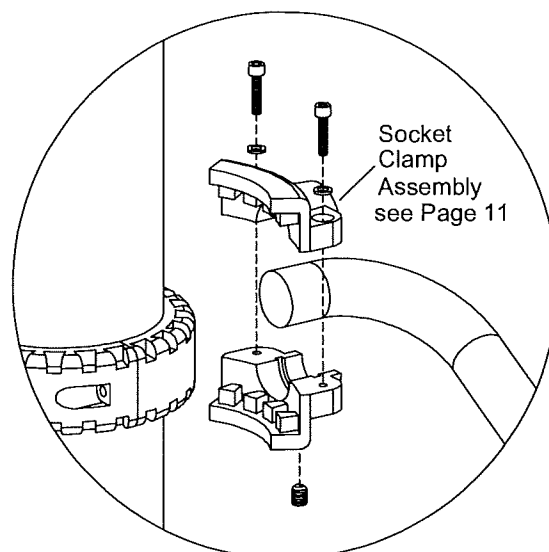

Figure 9



IMPORTANT NOTES: Read First

(A) Use liquid thread lock (such as Loctite[®]) with all threaded hardware. **Important:** Liquid thread lock (prior to curing) helps to eliminate the common problem of "thread seizure" in stainless steel hardware by serving as a lubricant during assembly.

(B) Do not pour concrete until the equipment is completely assembled, leveled and plumbed. Concrete must be allowed to cure completely before using the equipment (at least 72 hours).

(C) Refer to Installation Manual for R5-1310 Transition Wall assembly instructions.

(D) Use appropriate compliant protective surfacing and adjust footing depths accordingly. See free publication - The Handbook for Public Playground Safety, Publication #325 at www.CPSC.gov for the surfacing appropriate for the fall height of the equipment or consult your surfacing supply representative.

FIGURE 1
Climbing Wall

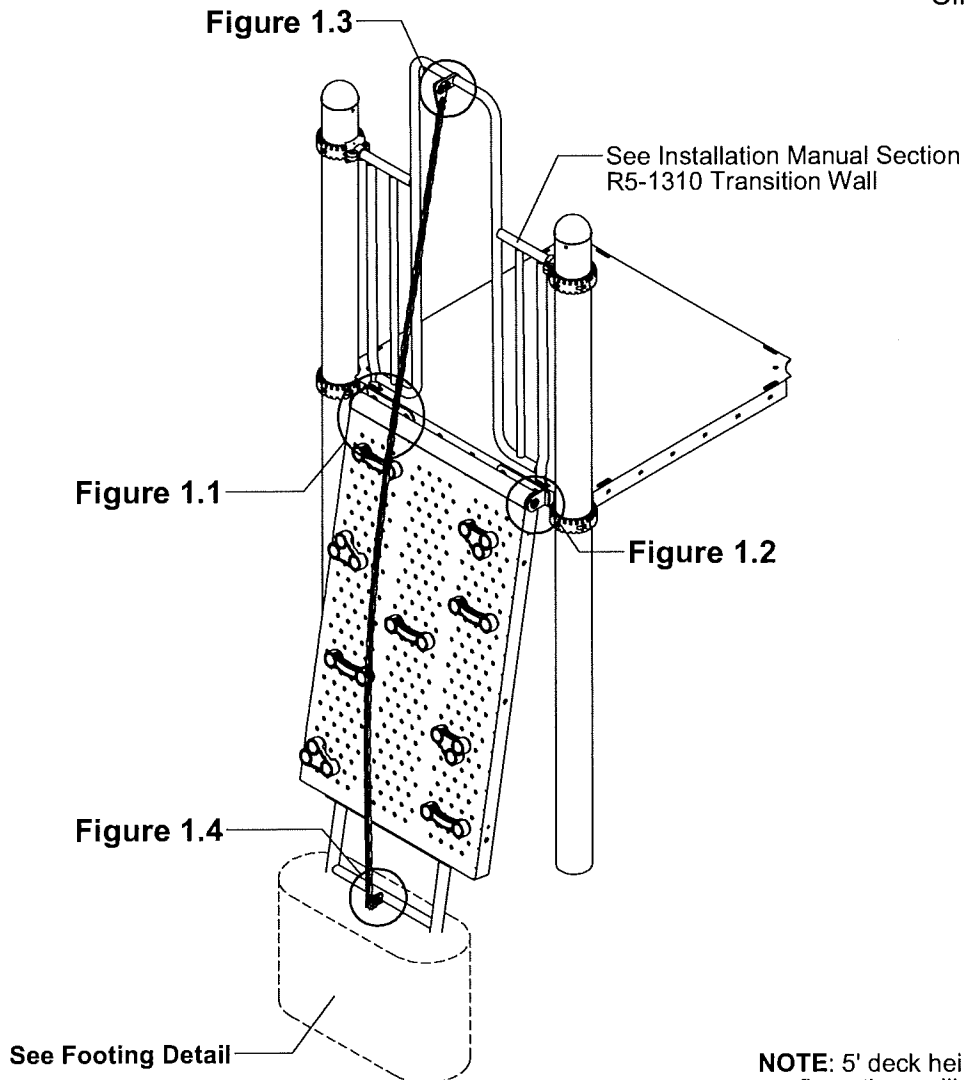

NOTE: 5' deck height shown. Other configurations will vary slightly, but does not affect assembly.



Manufactured by Krauss Craft, Inc.
www.playcraftsystems.com

For Customer Service Call
800.333.8519 (U.S.A.) or
541.955.9199 (International)

Rev L
6/30/2010

Step 2 (Factory Assembled)

Attach Climb Chain Hanger to Grip Climb Wall Chain as shown in Figure 2. (See Note A)

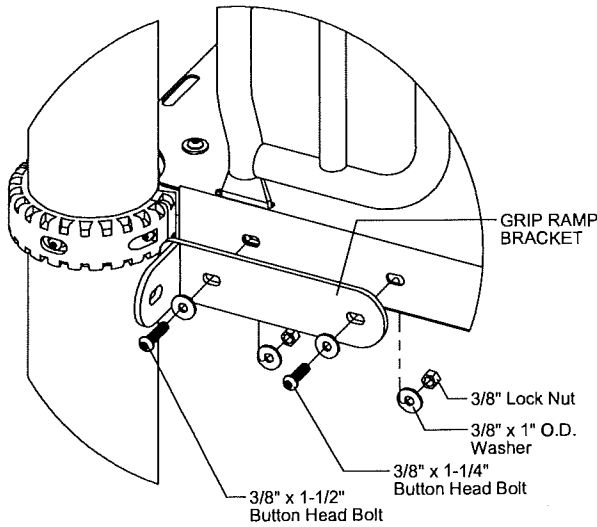

Figure 1.1

Step 4

Attach Grip Climb Wall Leg to Grip Climb Wall as shown in Figure 3. (See Note A)

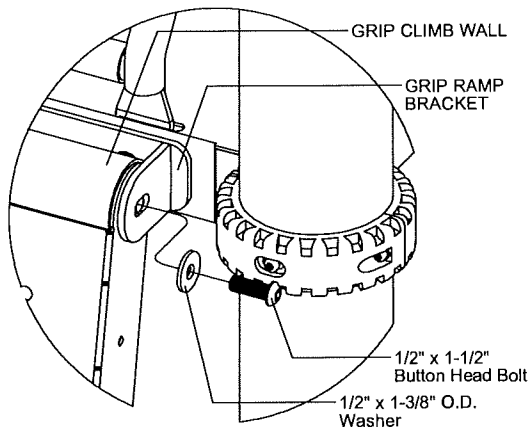

Figure 1.2

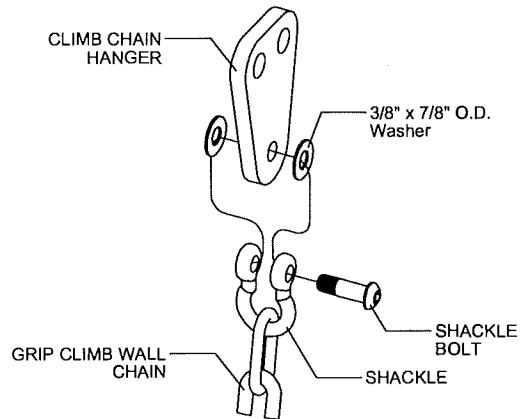

FIGURE 2

Step 3

Using Grip Climb Wall as a guide, position and attach Grip Ramp Brackets and Transition Wall to deck as shown in Figure 1.1. Fully tighten Grip Ramp Brackets at this time. (See Notes A & C)

NOTE: Use (2) 3/8" x 1-1/2" Button Head Bolts included with Climbing Wall assembly.

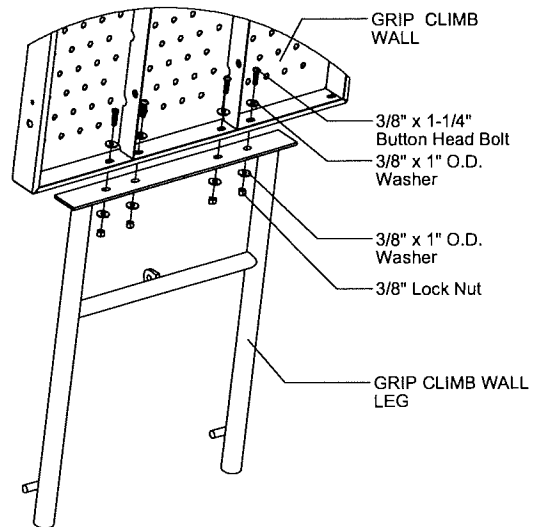

FIGURE 3

Step 5

Place Grip Climb Wall Leg into footing hole and attach Grip Climb Wall to Grip Ramp Brackets as shown in Figure 1.2. (See Note A).

Parts List

60" DECK HEIGHT		
Part #	DESCRIPTION	QTY
CE-4370	Grip Climb Wall 60"	1
FS-1214	Grip Climb Wall Leg	1
FS-1214-BRKT	Grip Ramp Bracket	2
GE-4152	Ramp Grip 2-Hole	5
GE-4190	Ramp Grip 3-Hole	4
451165	Shackle w/Bolt	1
9103032-TR	Bolt Button Head 3/8" x 3/4"	2
9103062-TR	Bolt Button Head 3/8" x 1-1/4"	28
9103072-TR	Bolt Button Head 3/8" x 1-1/2"	2
9105072	Bolt Button Head 1/2" x 1-1/2"	2
9333002	Washer Flat 3/8" x 1" O.D. x .100" thick	40
9333042	Washer Flat 3/8" x 7/8" O.D.	2
9335062-5	Washer Flat 1/2" x 1-3/8" OD	2
9345002	Washer Flat SAE 1/2"	2
9413002	Nut Lock 3/8"	8
9443022-TR	Nut Barrel 3/8" x 5/8" BH	2

72" DECK HEIGHT		
Part #	DESCRIPTION	QTY
CE-4369	Grip Climb Wall 72"	1
FS-1214	Grip Climb Wall Leg	1
FS-1214-BRKT	Grip Ramp Bracket	2
GE-4152	Ramp Grip 2-Hole	6
GE-4190	Ramp Grip 3-Hole	6
451165	Shackle w/Bolt	1
9103032-TR	Bolt Button Head 3/8" x 3/4"	2
9103062-TR	Bolt Button Head 3/8" x 1-1/4"	36
9103072-TR	Bolt Button Head 3/8" x 1-1/2"	2
9105072	Bolt Button Head 1/2" x 1-1/2"	2
9333002	Washer Flat 3/8" x 1" O.D. x .100" thick	48
9333042	Washer Flat 3/8" x 7/8" O.D.	2
9335062-5	Washer Flat 1/2" x 1-3/8" OD	2
9345002	Washer Flat SAE 1/2"	2
9413002	Nut Lock 3/8"	8
9443022-TR	Nut Barrel 3/8" x 5/8" BH	2

Assembled Parts List

Part #	DESCRIPTION	QTY
AE-4340	Climb Chain Hanger	1
HE-4371	Grip Climb Wall Chain	1
451165	Shackle w/Bolt	1
9333042	Washer Flat 3/8" x 7/8" O.D.	2

Specifications

CLIMB CHAIN HANGER:

Shall be laser-cut from 3/8" plate steel. The Climb Chain Hanger shall have a multi-stage baked-on powder coat finish.

GRIP CLIMB WALL:

Shall be formed from 12 gauge punched sheet steel with a hole pattern to provide a variety of attachment points for die-cast aluminum grips. The Grip Climb Wall will be Play-Tuff™ coated after fabrication.

GRIP CLIMB WALL CHAIN:

Shall be 5/0 galvanized low-carbon steel chain with silver shield finish. The Grip Climb Wall Chain shall be Play-Tuff™ coated.

GRIP CLIMB WALL LEG:

Shall be fabricated using 1.660" O.D. 11 gauge steel tubing welded to a 1/4" steel mounting plate and 1.315" O.D. 12 gauge steel cross member. A 3/8" steel tab will be welded to cross member. The Grip Climb Wall Leg shall have a multi-stage baked-on powder coat finish.

GRIP RAMP BRACKET:

Shall be two part laser-cut and welded 1/4" steel. The Grip Ramp Bracket shall have a multi-stage baked-on powder coat finish.

RAMP GRIP:

Shall be one piece precision die-cast from a high strength aluminum alloy. The Ramp Grip comes in 2-hole and 3-hole styles and finished with vinyl coating.

HARDWARE:

Shall be stainless steel, zinc/nickel plated or galvanized as required to resist rust and corrosion.

Maintenance

Periodically tighten all screws, bolts and nuts. A periodic inspection of all parts is necessary. If a part is broken or worn, replace immediately. For general maintenance please refer to our Playground Maintenance Manual.



Manufactured by Krauss Craft, Inc.
www.playcraftsystems.com

For Customer Service Call
800.333.8519 (U.S.A.) or
541.955.9199 (International)

Rev L
6/30/2010

IMPORTANT NOTES: Read First

- (A) Use liquid thread lock (such as Loctite®) with all threaded hardware. **Important:** Liquid thread lock (prior to curing) helps to eliminate the common problem of "thread seizure" in stainless steel hardware by serving as a lubricant during assembly.
- (B) Do not pour concrete until the equipment is completely assembled, leveled and plumbed. Concrete must be allowed to cure completely before using the equipment (at least 72 hours).
- (C) Refer to Installation Manual for 1309 Half Wall assembly instructions.
- (D) Use appropriate compliant protective surfacing and adjust footing depths accordingly. See free publication - The Handbook for Public Playground Safety, Publication #325 at www.CPSC.gov for the surfacing appropriate for the fall height of the equipment or consult your surfacing supply representative.

FIGURE 1
Chain Net Climber

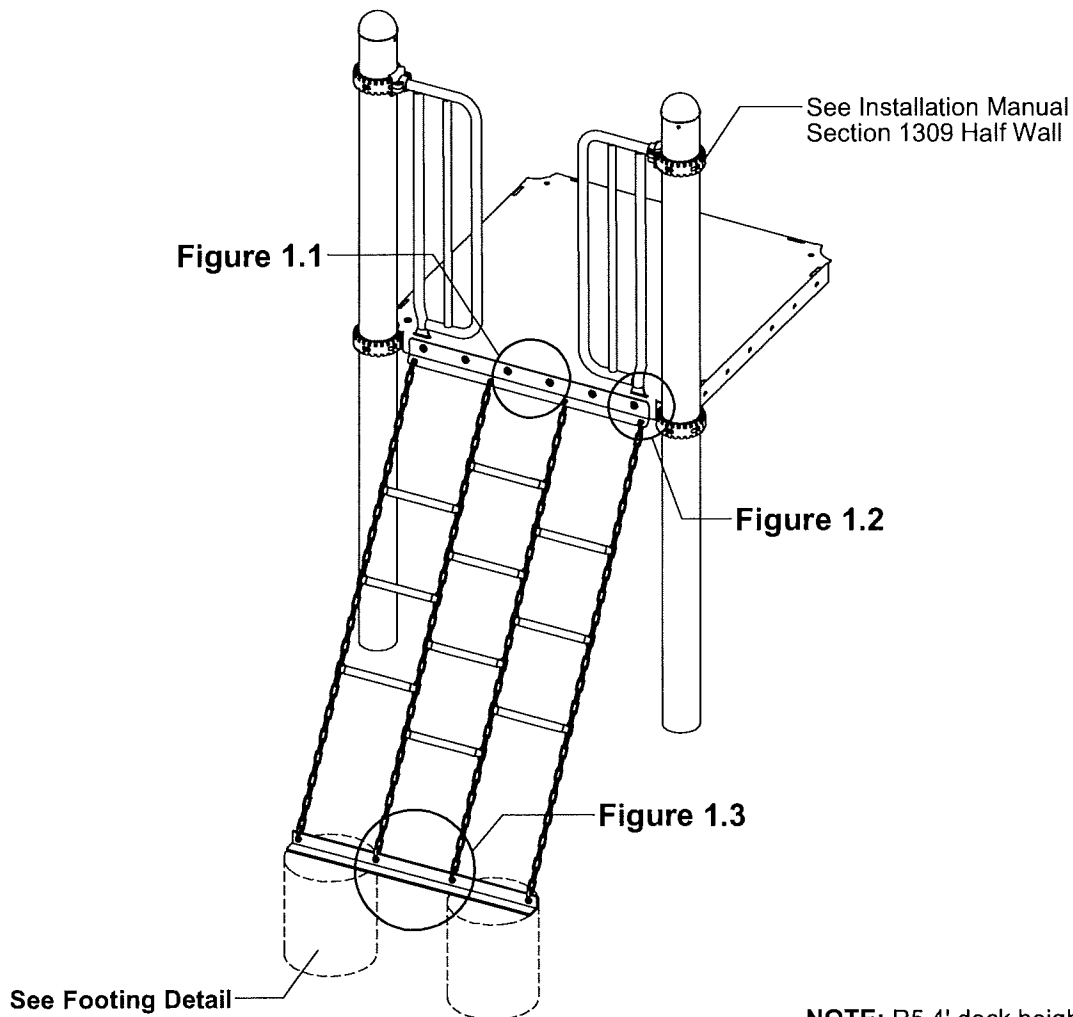

NOTE: R5 4' deck height shown.
Other configurations will vary slightly,
but does not affect assembly.

Step 2

Attach Chain Net Climber to deck as shown in Figure 1.1. (See Note A)

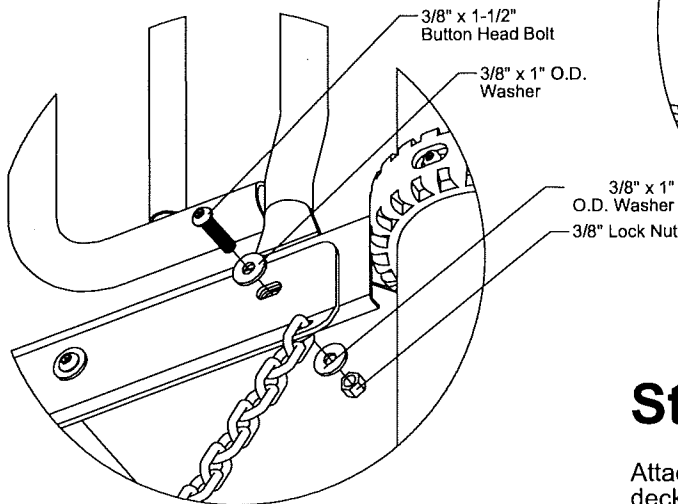

Figure 1.2

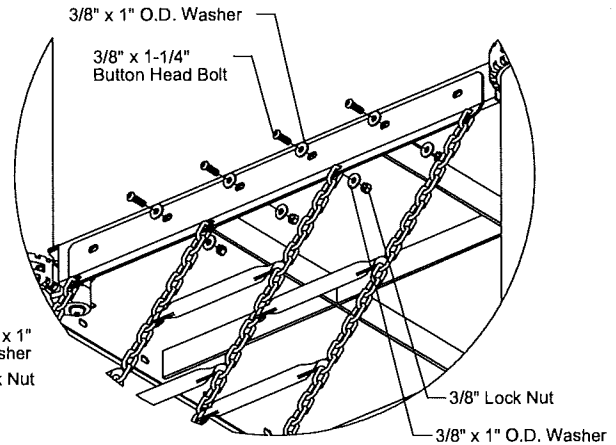

Figure 1.1

Step 3

Attach Half Walls to deck. Confirm the slot alignment of deck, Chain Net Climber Mount and Half Wall Tabs, then attach as shown in Figure 1.2. (See Notes A & C)

NOTE: Use (2) 3/8" x 1-1/2" Button Head Bolts included with Chain Net Climber.

Step 4

Attach Chain Net to Chain Net Foot as shown in Figure 1.3. (See Note A)

NOTE: To maintain desired angle and slack, chain length adjustments will be required for some deck heights.

Step 5

Fully tighten all fasteners according to the "TIGHTENING TORQUE FOR HARDWARE" section of the Installation Manual.

Step 6

Pour concrete into footing holes. Keep chains tight while setting the base of the Chain Net Foot on top of the concrete and the footing anchors in the concrete.

Brace Chain Net to maintain approximate position during concrete curing process. Allow at least 72 hours to cure before using this equipment. (See Note B)

Step 7

Place appropriate compliant protective surfacing under and around Chain Net Climber. (See Note D)

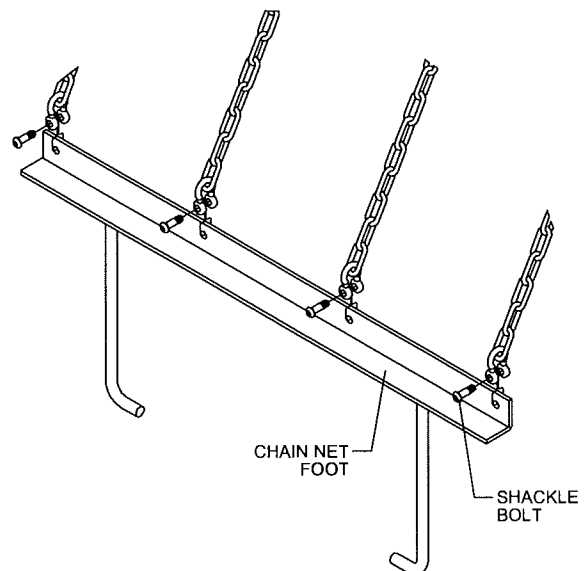

Figure 1.3

DISC CLIMBER ASSEMBLY

R5-1233

Page 1 of 2

Assembly View

Disc Climber
(3 Disc)
#1233-3

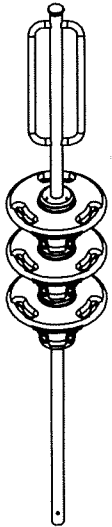

Disc Climber
(4 Disc)
#1233-4

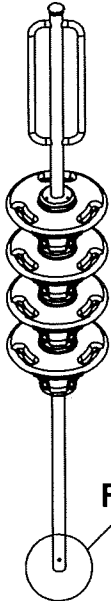

Disc Climber
(5 Disc)
#1233-5

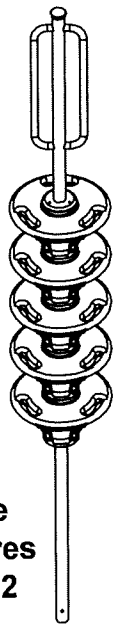

Disc Climber
(6 Disc)
#1233-6

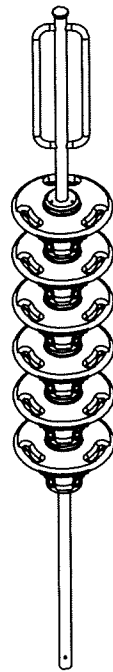

See
Figures
1 & 2

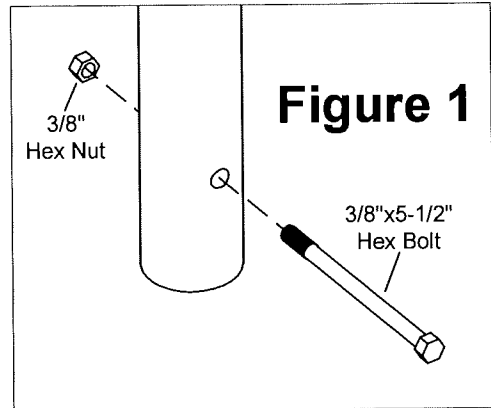

Figure 1

Figure 2

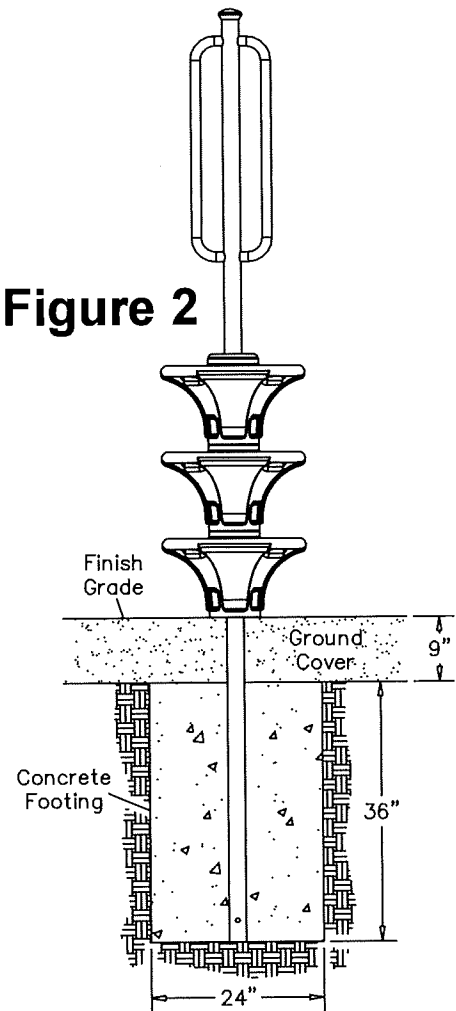
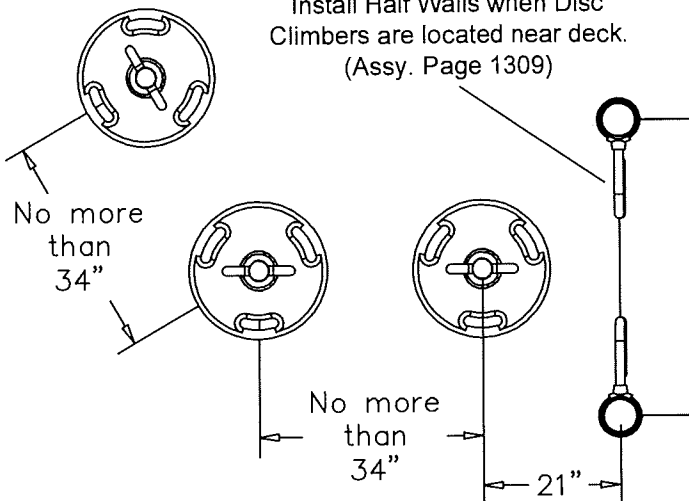

Figure 3

Install Half Walls when Disc Climbers are located near deck.
(Assy. Page 1309)



Note: Handles point toward each other and deck when conjunctive with structure.



Manufactured by
Krauss Craft, Inc.

Phone: 800.333.8519

Rev. A

IMPORTANT NOTES: Read First

- (A) Use liquid thread lock (such as Loctite®) with all threaded hardware. **Important:** Liquid thread lock (prior to curing) helps to eliminate the common problem of "thread seizure" in stainless steel hardware by serving as a lubricant during assembly.
- (B) Do not pour concrete until the equipment is completely assembled, leveled and plumbed. Concrete must be allowed to cure completely before using the equipment (at least 72 hours).
- (C) Refer to Installation Manual for 09 Collars, 11 Socket Clamps, and 1309 Half Wall assembly instructions.
- (D) Use appropriate compliant protective surfacing and adjust footing depths accordingly. See free publication - The Handbook for Public Playground Safety, Publication #325 at www.CPSC.gov for the surfacing appropriate for the fall height of the equipment or consult your surfacing supply representative.
- (E) Caution must be given to Toggle Assembly as parts may become fragile during insertion and final securing.

FIGURE 1
Curved Erector Rock to Deck

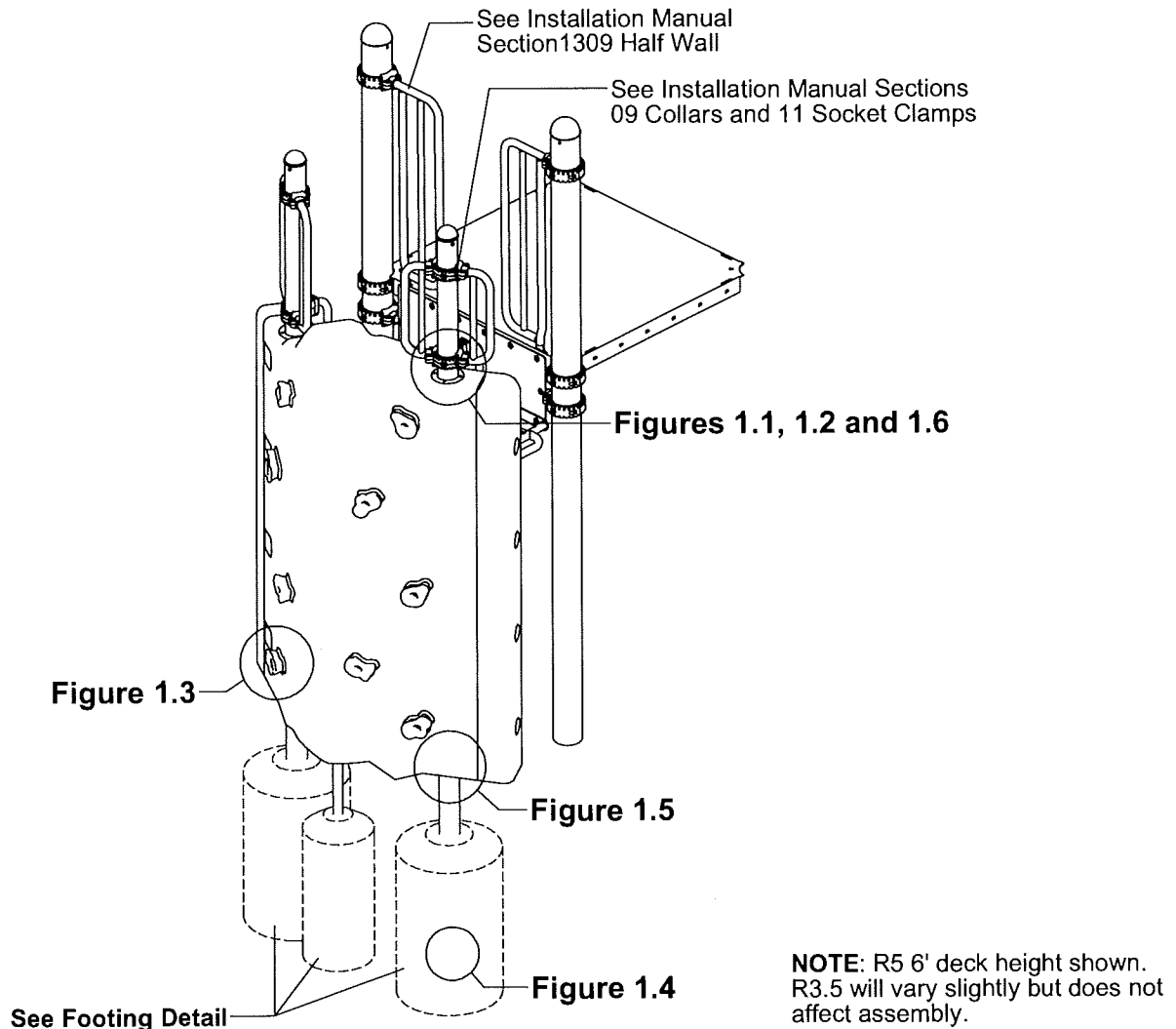

Step 1

Refer to Footing Layout and mark footing hole locations. Dig (1) Ø 12" and (2) Ø 18" footing holes. Refer to Footing Detail for depth and details.

IMPORTANT: For areas with soft soil conditions, larger footings may be required.

* Footing depth must be adjusted to compensate for the depth/thickness requirements of selected safety surfacing. See Section 06.1 of the Installation Manual.

Footing Detail

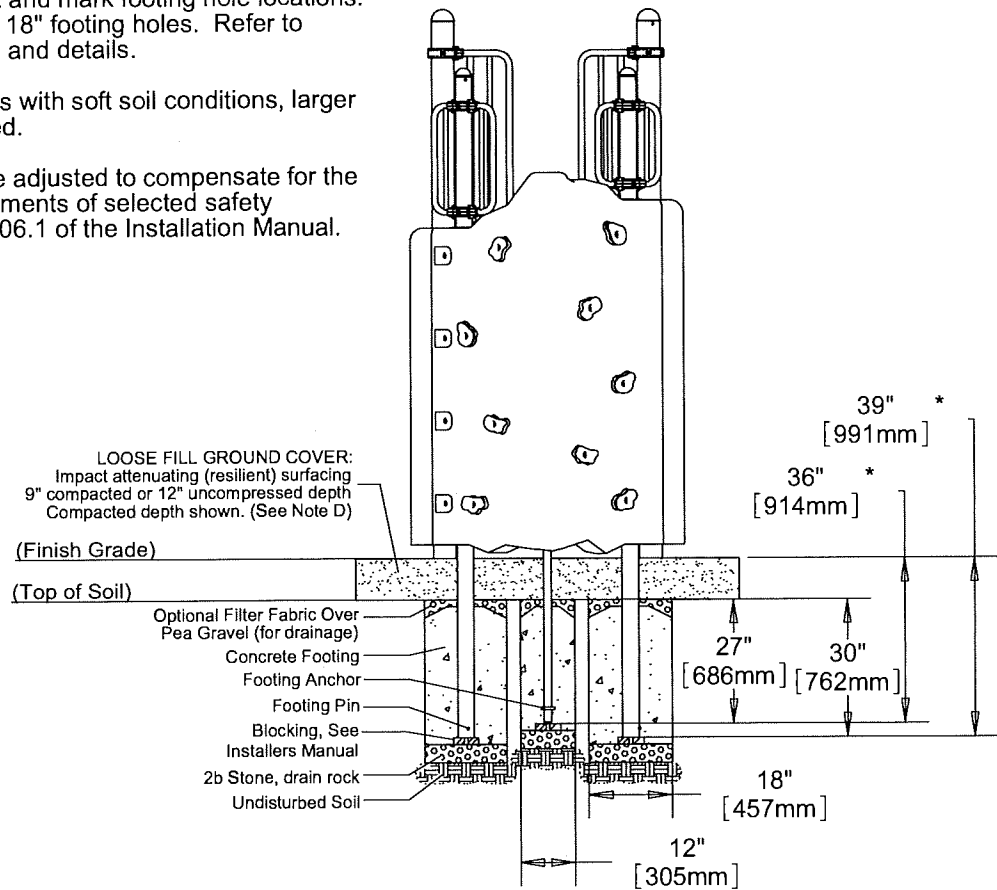

Top View - Footing Layout

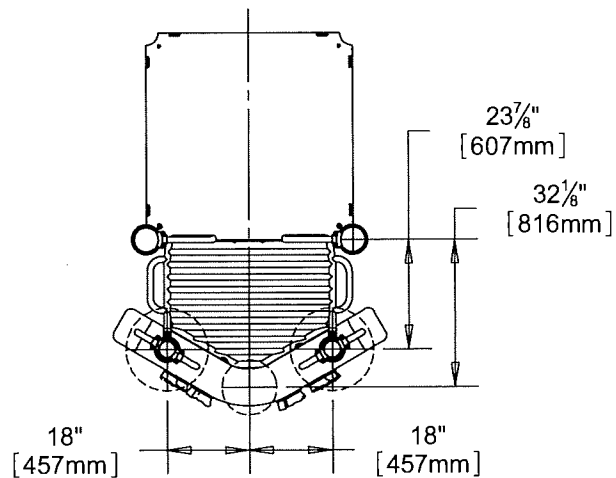

Step 6

Attach Erector Rock Posts and Leg to Erector Rock Wall as shown in Figure 1.5. (See Note A)

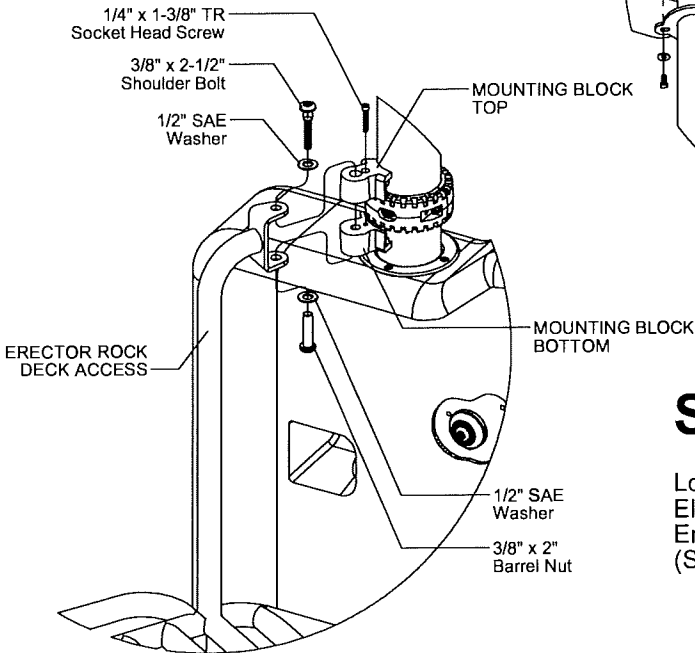

Figure 1.6

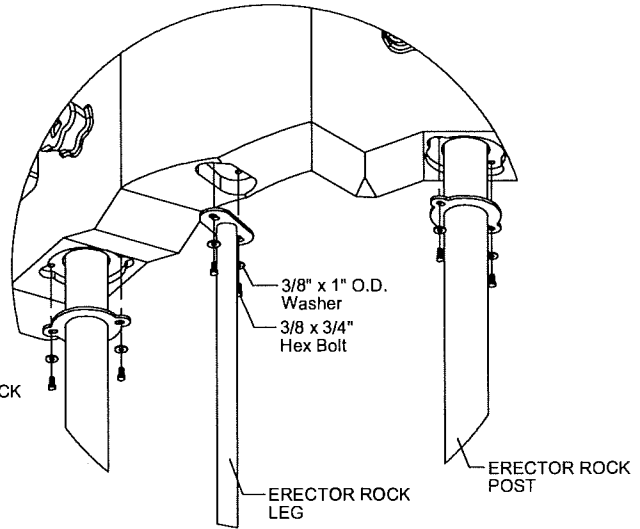

Figure 1.5

Step 7

Locate and attach collars at heights shown in Side Elevation. Attach Erector Rock Deck Access to Erector Rock Post as shown in Figure 1.6. (See Notes A & C)

Step 8

For 48" and 60" Deck Heights Only

Place Erector Rock Posts and Leg into footing holes and attach Erector Rock Deck Access and Half Walls to deck as shown in Figure 2. (See Notes A & B)

NOTE: Use (2) 3/8" x 1-1/2" Button Head Bolts included with Curved Erector Rock to Deck assembly.

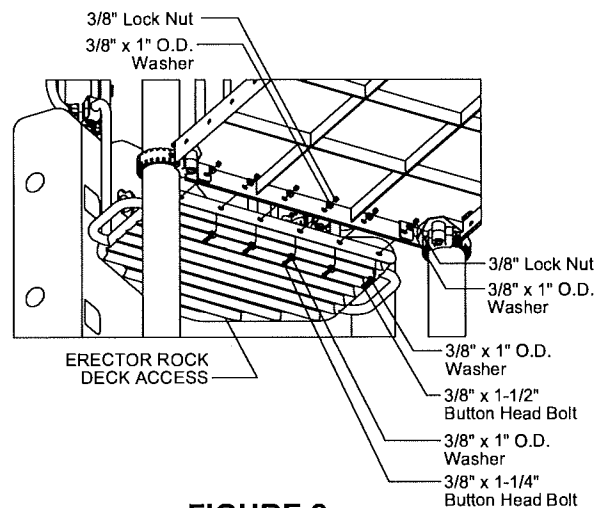

FIGURE 2

4' Deck Height

5' Deck Height

PARTS LIST		
Part #	DESCRIPTION	QTY
EE-4614	Erector Rock Grip Spacer	9
FS-1236-12	Erector Rock Post 12'	2
FS-1236-DK4	Erector Rock Deck Access 4'	1
FS-1236-HND-A	Erector Rock Handle Long	2
FS-1236-HND-B	Erector Rock Handle Short	2
FS-1236-LEG	Erector Rock Leg	1
GE-4586	Wall Grip #1	3
GE-4587	Wall Grip #2	3
GE-4588	Wall Grip #3	3
GG-8110	Mounting Block 4 Top R3.5	2
GG-8111	Mounting Block 4 Bottom R3.5	2
GG-8135	Post Cap R3.5 Dome	2
HS-1001-R35	Socket Clamp Set R3.5	8
HS-1004-R35	R35 Collar Set	4
581356	3/8" x 6" Threaded Stud	9
9103062-TR	Bolt Button Head 3/8" x 1-1/4"	4
9103072-TR	Bolt Button Head 3/8" x 1-1/2"	2
9123032	Bolt Hex 3/8" x 3/4"	6
9123231	Bolt Hex 3/8" x 5-1/2"	2
9143112-TR	Bolt Shoulder 3/8" x 2-1/2" BH	2
9271062-TR	Screw Tek 1/4" x 1-1/4" BH TR	4
9281062-5-TR	Screw Soc HD CS 1/4" x 1-3/8" TR	2
9333002	Washer Flat 3/8" x 1" O.D. x .100" thick	18
9345002	Washer Flat SAE 1/2"	22
9413002	Nut Lock 3/8"	6
9443092-TR	Nut Barrel 3/8" x 2" BH	20
9483602	Nut Hex 3/8"	2

PARTS LIST		
Part #	DESCRIPTION	QTY
EE-4614	Erector Rock Grip Spacer	9
FS-1236-12	Erector Rock Post 12'	2
FS-1236-DK5	Erector Rock Deck 5'	1
FS-1236-HND-A	Erector Rock Handle Long	2
FS-1236-HND-B	Erector Rock Handle Short	2
FS-1236-LEG	Erector Rock Leg	1
GE-4586	Wall Grip #1	3
GE-4587	Wall Grip #2	3
GE-4588	Wall Grip #3	3
GG-8110	Mounting Block 4 Top R3.5	2
GG-8111	Mounting Block 4 Bottom R3.5	2
GG-8135	Post Cap R3.5 Dome	2
HS-1001-R35	Socket Clamp Set R3.5	8
HS-1004-R35	R35 Collar Set	4
581356	3/8" x 6" Threaded Stud	9
9103062-TR	Bolt Button Head 3/8" x 1-1/4"	4
9103072-TR	Bolt Button Head 3/8" x 1-1/2"	2
9123032	Bolt Hex 3/8" x 3/4"	6
9123231	Bolt Hex 3/8" x 5-1/2"	2
9143112-TR	Bolt Shoulder 3/8" x 2-1/2" BH	2
9271062-TR	Screw Tek 1/4" x 1-1/4" BH TR	4
9281062-5-TR	Screw Soc HD CS 1/4" x 1-3/8" TR	2
9333002	Washer Flat 3/8" x 1" O.D. x .100" thick	18
9345002	Washer Flat SAE 1/2"	22
9413002	Nut Lock 3/8"	6
9443092-TR	Nut Barrel 3/8" x 2" BH	20
9483602	Nut Hex 3/8"	2



Manufactured by Krauss Craft, Inc.
www.playcraftsystems.com

For Customer Service Call
800.333.8519 (U.S.A.) or
541.955.9199 (International)

Rev G
7/26/2010

Specifications

ERECTOR ROCK:

Shall be constructed of UV-stabilized, rotationally molded, linear, low density polyethylene with an average wall thickness of .250".

ERECTOR ROCK DECK ACCESS:

Shall be fabricated using 1.315" O.D. 12 gauge steel tubing with welded 3/16" thick steel mounting plate and two steel clevises. The Erector Rock Deck Access shall have a multi-stage baked-on powder coat finish.

ERECTOR ROCK GRIPS:

Shall be one piece and precision die-cast from a high-strength aluminum alloy. The Erector Rock Grips shall be Play-Tuff™ coated after fabrication.

ERECTOR ROCK HANDLE:

Shall be fabricated Using 1.315" O.D. 12 gauge steel tubing with welded 1.029" O.D. 14 gauge steel vertical rung. The Erector Rock Handle shall have a multi-stage baked-on powder coat finish.

ERECTOR ROCK POST:

Shall be fabricated using 3.5" O.D. 11 gauge steel tubing with welded 1/4" thick steel plate. The Erector Rock Post shall have a multi-stage baked-on powder coat finish.

FILLER SUPPORT 12":

Shall be fabricated from 10 gauge sheet steel. The Filler Support 12" shall have a multi-stage baked-on powder coat finish.

R3.5 SPIRAL SLIDE SUPPORT:

Shall be fabricated from 10 gauge Sheet Steel. The R3.5 Spiral Slide Support shall have a multi-stage baked-on powder coat finish.

R3.5 POST CAPS, MOUNTING LUGS, COLLARS, SOCKET CLAMPS AND MOUNTING BLOCKS:

Shall be precision die-cast from a high-strength aluminum alloy. The R3.5 Post Caps, Mounting Lugs, Collars, Socket Clamps and Mounting Blocks have a multi-stage baked-on powder coat finish.

HARDWARE:

Shall be stainless steel, zinc/nickel plated or galvanized as required to resist rust and corrosion.

Maintenance

Periodically tighten all screws, bolts and nuts. A periodic inspection of all parts is necessary. If a part is broken or worn, replace immediately. For general maintenance please refer to our Playground Maintenance Manual.



Manufactured by Krauss Craft, Inc.
www.playcraftsystems.com

For Customer Service Call
800.333.8519 (U.S.A.) or
541.955.9199 (International)

Rev G
7/26/2010

IMPORTANT NOTES: Read First

(A) Use liquid thread lock (such as Loctite®) with all threaded hardware. **Important:** Liquid thread lock (prior to curing) helps to eliminate the common problem of "thread seizure" in stainless steel hardware by serving as a lubricant during assembly.

(B) Refer to Installation Manual for R5-09 Collars, R5-11 Socket Clamps, and 1705 Double Slide assembly instructions.

FIGURE 1
Double Sit Down R5

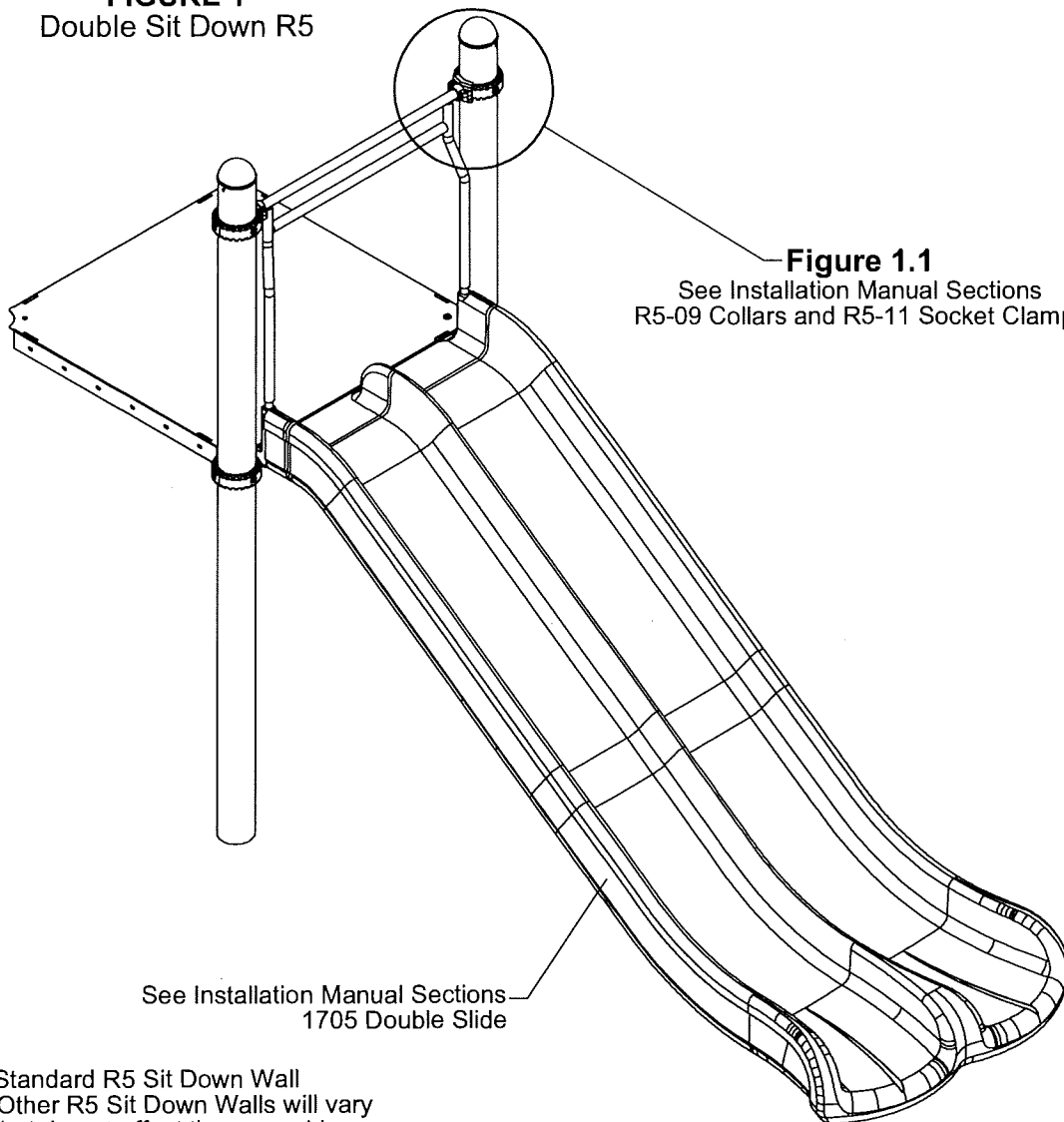

Figure 1.1
See Installation Manual Sections
R5-09 Collars and R5-11 Socket Clamps

See Installation Manual Sections
1705 Double Slide

NOTE: Standard R5 Sit Down Wall shown. Other R5 Sit Down Walls will vary slightly, but do not affect the assembly.



Manufactured by Krauss Craft, Inc.
www.playcraftsystems.com

For Customer Service Call
800.333.8519 (U.S.A.) or
541.955.9199 (International)

Rev E
5/26/2009

IMPORTANT NOTES: Read First

(A) Use liquid thread lock (such as Loctite[®]) with all threaded hardware. **Important:** Liquid thread lock (prior to curing) helps to eliminate the common problem of "thread seizure" in stainless steel hardware by serving as a lubricant during assembly.

(B) This Assembly requires additional Assembly Pages. See also Assembly Page R5-09 Collars and R5-11 Socket Clamps.

(C) Collar Locations: The Collar is to be placed 39" from top of the collar to top of the deck.

Assembly Views

Standard Half Wall (Set and Square Deck Shown)

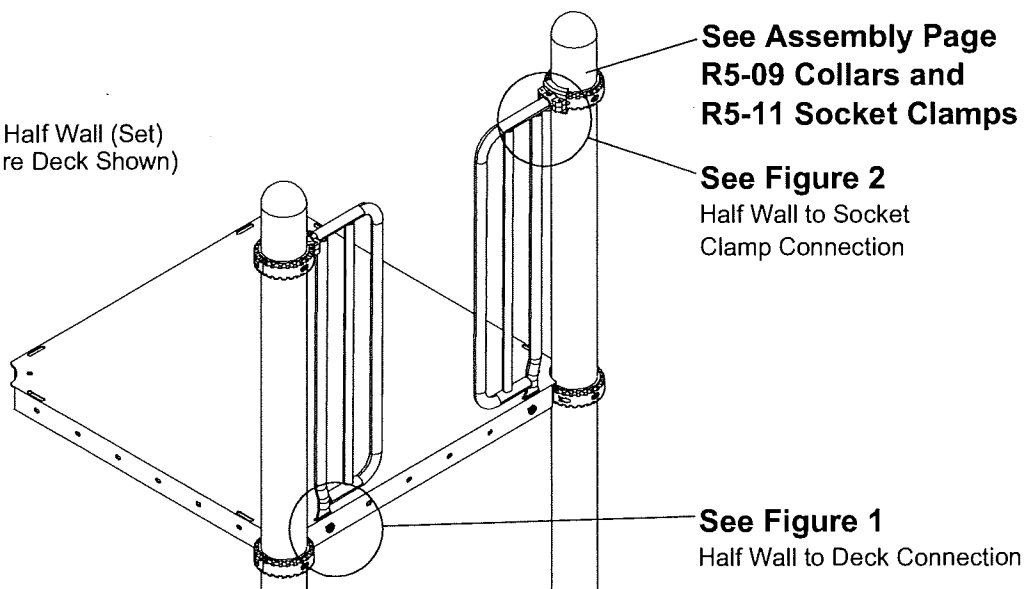

*Dimension given is from Top of Deck to Top of Collar.

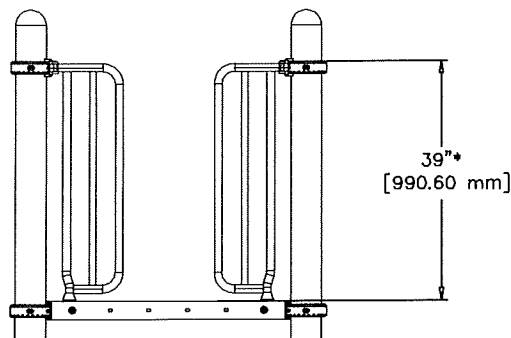

Elevation

Front View

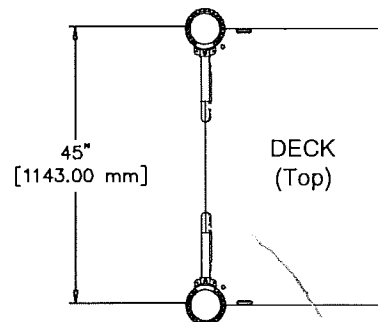

Footing Layout

Top View



Manufactured by Krauss Craft, Inc.
www.playcraftsystems.com

For Customer Service Call
800.333.8519 (U.S.A.) or
541.955.9199 (International)

Rev G

HALF WALL (HANDLE) ASSEMBLY

R5 - 1309

Page 3 of 3

Parts List

(1) Half Wall (Handle)

<u>PART #</u>	<u>DESCRIPTION</u>	<u>QTY.</u>
-VARIES-	Half Wall	1
See Pg. R5-11	Socket Clamp Assembly	1
9103062-TR	Bolt Button Head 3/8" x 1-1/4"	1
9333002	Washer Flat 3/8" x 1" x .100 thick	2
9413002	Nut Lock 3/8"	1

Half Wall Options

<u>PART #</u>	<u>DESCRIPTION</u>
FS-1309-R	Half Wall R5
FS-1309-R-TRNFR	Half Wall Transfer R5
FS-1309-RADA	Half Wall ADA Steps R5

Installation

Step 1.

Locate and mark the position of the Collars on the Support Posts. Refer to Elevation View for Collar locations. See Note C. See also Assembly Page R5 - 09 Collars for hardware type and orientation.

Step 2.

Loosely attach the Half Wall to the Deck. Verify left or right hand location on Top View of structure prior to installation. Refer to Figure 1 for hardware type and orientation.

Step 3.

Loosely attach the Half Wall to the Post Collars using the Socket Clamps. Refer to Figure 2 for hardware type and orientation. See also Assembly Page R5-11 Socket Clamps for additional hardware details.

Step 4.

Apply liquid thread lock and fully tighten all fasteners according to the "TIGHTENING TORQUE FOR HARDWARE" Section of the Installer's Manual. See Note A.

Specifications

HALF WALL R5:

Shall be constructed of 1.315" O.D., 12 gauge steel tubing outer rails with 1.029" O.D., 14 gauge steel tubing welded vertically. The Half Wall may also have welded mounting tabs and/or plates. The Half Wall R5 has a multi-stage baked on powder coat finish.

SOCKET CLAMPS:

Shall be two-part and precision die-cast from a high strength aluminum alloy. The Socket Clamps have a multi-stage baked-on powder coat finish.

HARDWARE:

Shall be stainless steel, zinc/nickel plated or galvanized as required to resist rust and corrosion.

Maintenance

Periodically tighten all screws, bolts and nuts. A periodic inspection of all parts is necessary. If a part is broken or worn, replace immediately. For general maintenance please refer to our Playground Maintenance Manual.



Manufactured by Krauss Craft, Inc.
www.playcraftsystems.com

For Customer Service Call
800.333.8519 (U.S.A.) or
541.955.9199 (International)

Rev G

IMPORTANT NOTES: Read First

(A) Use liquid thread lock (such as Loctite®) with all threaded hardware. **Important:** Liquid thread lock (prior to curing) helps to eliminate the common problem of "thread seizure" in stainless steel hardware by serving as a lubricant during assembly.

(B) Refer to Installation Manual for 09 Collars and 11 Socket Clamps assembly instructions.

(C) Use appropriate compliant protective surfacing and adjust footing depths accordingly. See free publication - The Handbook for Public Playground Safety, Publication #325 at www.CPSC.gov for the surfacing appropriate for the fall height of the equipment or consult your surfacing supply representative.

FIGURE 1
Transition Wall

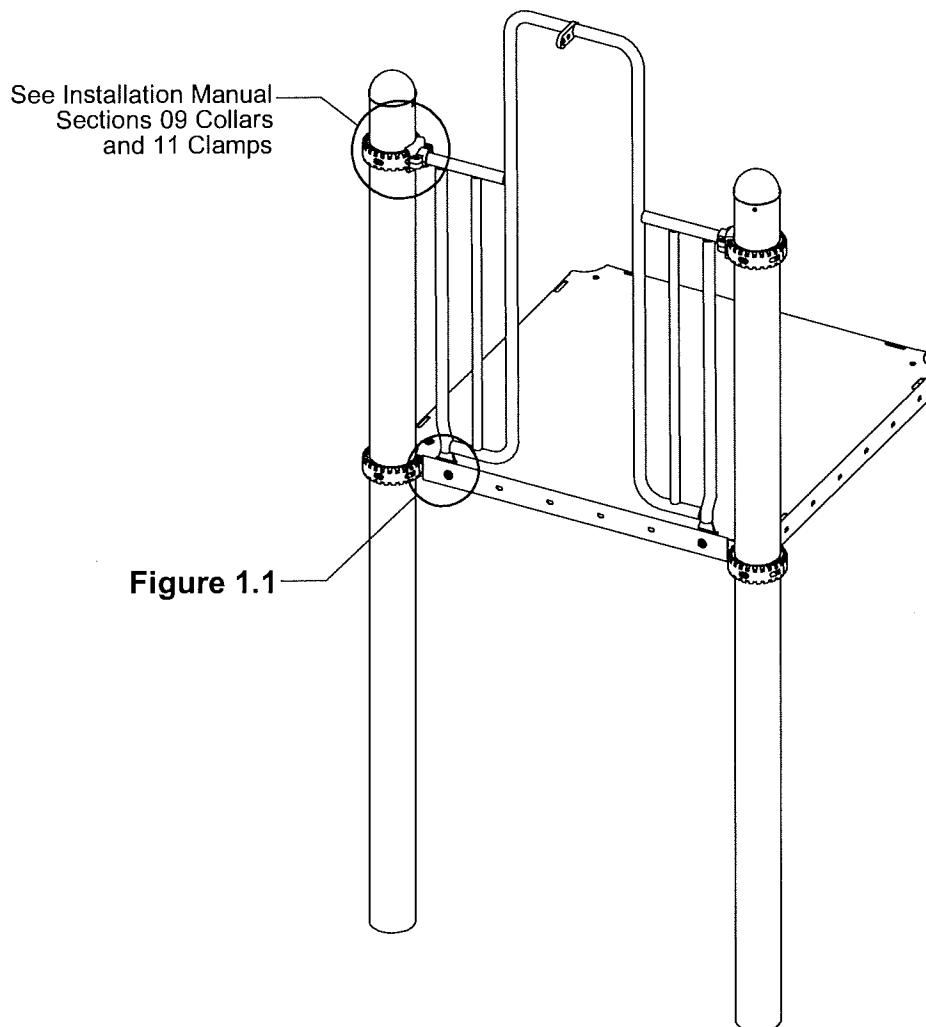

NOTE: R5 Single Tab Transition Wall shown. Other configurations will vary slightly but do not affect assembly.

Specifications

TRANSITION WALL:

Shall be fabricated of 1.315" O.D. steel tubing with 1.029" O.D. steel tubing inner rails. There shall be (1) or (2) 1/2" thick steel tabs welded to the main rail. The Transition Wall has a multi-stage baked on powder coat finish.

SOCKET CLAMPS:

Shall be two-part and precision die-cast from a high strength aluminum alloy. The Socket Clamps have a multi-stage baked on powder coat finish.

HARDWARE:

Shall be stainless steel, zinc/nickel plated or galvanized as required to resist rust and corrosion.

Parts List

R3.5 SINGLE TAB

Part #	DESCRIPTION	QTY
FS-1310-R35	Transition Wall R3.5	1
HS-1001-R35	Socket Clamp Set R3.5	2
9103062-TR	Bolt Button Head 3/8" x 1-1/4"	2
9333002	Washer Flat 3/8" x 1" O.D. x .100" thick	4
9413002	Nut Lock 3/8"	2

R3.5 DOUBLE TAB

Part #	DESCRIPTION	QTY
FS-1310-R35-2	Transition Wall 2 Tab R3.5	1
HS-1001-R35	Socket Clamp Set R3.5	2
9103062-TR	Bolt Button Head 3/8" x 1-1/4"	2
9333002	Washer Flat 3/8" x 1" O.D. x .100" thick	4
9413002	Nut Lock 3/8"	2

R5 SINGLE TAB

Part #	DESCRIPTION	QTY
FS-1310-R	Transition Wall R5	1
HS-1001-R5	Socket Clamp Set R5	2
9103062-TR	Bolt Button Head 3/8" x 1-1/4"	2
9333002	Washer Flat 3/8" x 1" O.D. x .100" thick	4
9413002	Nut Lock 3/8"	2

R5 DOUBLE TAB

Part #	DESCRIPTION	QTY
FS-1310-R2	Transition Wall 2 Tab R5	1
HS-1001-R5	Socket Clamp Set R5	2
9103062-TR	Bolt Button Head 3/8" x 1-1/4"	2
9333002	Washer Flat 3/8" x 1" O.D. x .100" thick	4
9413002	Nut Lock 3/8"	2

Maintenance

Periodically tighten all screws, bolts and nuts. A periodic inspection of all parts is necessary. If a part is broken or worn, replace immediately. For general maintenance please refer to our Playground Maintenance Manual.



Manufactured by Krauss Craft, Inc.
www.playcraftsystems.com

For Customer Service Call
800.333.8519 (U.S.A.) or
541.955.9199 (International)

Rev H
12/16/2009

IMPORTANT NOTES: Read First

(A) Use liquid thread lock (such as Loctite®) with all threaded hardware. **Important:** Liquid thread lock (prior to curing) helps to eliminate the common problem of "thread seizure" in stainless steel hardware by serving as a lubricant during assembly.

(B) This Assembly requires additional Assembly Pages. See also Assembly Page R5-09 Collars and R5-11 Socket Clamps.

(C) Collar Locations: Deck Mount - Collar measures 39" from top of deck to top of collar. Ground Mount - Collars measure 33-5/8" from top of lower collar to top of upper collar.

Under Deck Installation: Make sure distance between the bottom of the deck and the top of the panel(s) is less than 3-1/2" or greater than 9" to avoid head and neck entrapment.

(D) Use appropriate compliant protective surfacing and adjust footing depths accordingly. See free publication - The Handbook for Public Playground Safety, Publication #325 at www.CPSC.gov for the surfacing appropriate for the fall height of the equipment or consult your surfacing supply representative.

Assembly View

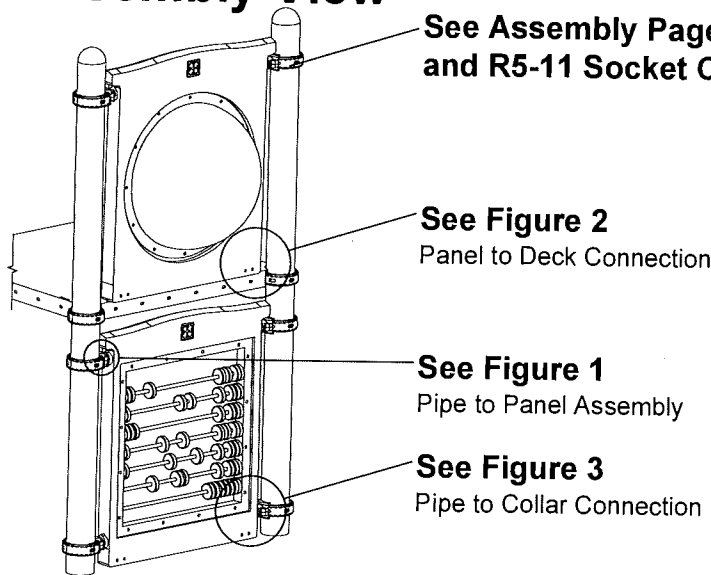

Important: These assembly instructions apply to all R5 Round and Square Rotomolded Panel Frames that deck and/or collar mount. Use specific panel instructions when available if installation requires different hardware and/or panel configurations other than shown in these instructions.

* Dimension given is from Top of Deck to Top of Collar

** Dimension given is from Top of Lower Collar to Top of Upper Collar

Elevation

Front View

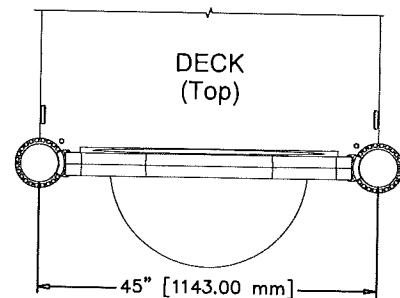
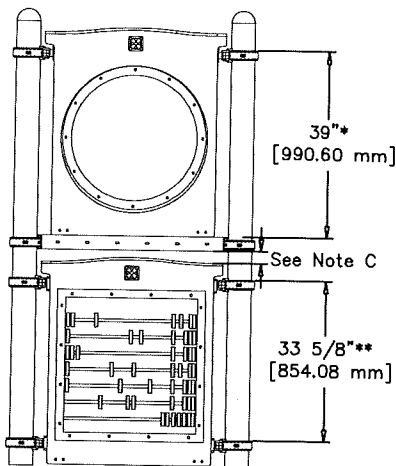

Post Spacing

Top View



Manufactured by Krauss Craft, Inc.
www.playcraftsystems.com

For Customer Service Call
800.333.8519 (U.S.A.) or
541.955.9199 (International)

Rev G

Parts List - Deck Mount

<u>PART #</u>	<u>DESCRIPTION</u>	<u>QTY.</u>
-VARIES-	Panel Frame (Rotomolded LDDPE)	1
007117-L	Roto Panel Bracket Left	1
007117-R	Roto Panel Bracket Right	1
See Pg. R5 - 11	Socket Clamp Assy.	2
9103062-TR	Bolt Button Head 3/8" x 1-1/4"	2
9103082-TR	Bolt Button Head 3/8" x 1-3/4"	4
9333002	Washer Flat 3/8" x 1" x .100 thick	12
9413002	Nut Lock 3/8"	6

Assembled Parts List - Deck Mount

<u>PART #</u>	<u>DESCRIPTION</u>	<u>QTY.</u>
410001	Collar Zinc	2
FS-1600	Cut Panel Pipe Roto 1" x 38-1/8"	1
9248112	Screw Drywall #8 x 2 -1/2" WS SQBH	4
9263022	Screw Soc Set 3/8" x 5/8"	2

Parts List - Ground Mt.

<u>PART #</u>	<u>DESCRIPTION</u>	<u>QTY.</u>
-VARIES-	Panel Frame (Rotomolded LDDPE)	1
See Pg. R5 - 11	Socket Clamp Assy.	4

Assembled Parts List - Ground Mount

<u>PART #</u>	<u>DESCRIPTION</u>	<u>QTY.</u>
410001	Collar Zinc	4
FS-1600	Cut Panel Pipe Roto 1" x 38-1/8"	2
9248112	Screw Drywall #8 x 2 -1/2" WS SQBH	8
9263022	Screw Soc Set 3/8" x 5/8"	4

Installation

Step 1. *This Step is Pre-Assembled*

Insert Pipe(s) into Panel and Secure with Zinc Collars. Refer to Figure 1 for hardware type and orientation.

Step 2.

Locate and mark the position of the Collars on the Support Posts. Refer to Elevation View for Collar locations. See Note C. See also Assembly Page R5 - 09 Collars for hardware type and orientation.

Step 3. - Deck Mount

Attach the Panel to the deck using the Roto Panel Brackets Left and Right. Refer to Figure 1 for hardware type and orientation.

Step 4.

Attach the Panel (Pipe) to the Post Collars using the Socket Clamps. Refer to Figure 2 for hardware type and orientation. See also Assembly Page R5-11 Socket Clamps for additional hardware details.

Step 5.

Apply liquid thread lock and fully tighten all fasteners according to the "TIGHTENING TORQUE FOR HARDWARE" Section of the Installer's Manual. See Note A.

Step 6.

Place appropriate compliant protective surfacing under and around Ground Mounted Panels. See Note D.

Specifications

PANEL ROUND/SQUARE R5 ROTO:

Shall be constructed of UV-stabilized, rotationally molded, Linear Low Density Polyethylene with an average single wall thickness of 1/4". The Panel Round has a 26.5" Diameter opening and the Panel Square has a 27.5" x 27.5" square opening. The Panels shall be 38" x 43-1/2" x 3" deep.

SOCKET CLAMPS:

Shall be two-part and precision die-cast from a high strength aluminum alloy. The Socket Clamps have a multi-stage baked-on powder coat finish.

ROTO PANEL BRACKET:

Shall be precision laser-cut and formed from 3/16" sheet steel. The Roto Panel Bracket has a multi-stage baked-on powder coat finish.

HARDWARE:

Shall be stainless steel, zinc/nickel plated or galvanized as required to resist rust and corrosion.

Maintenance

Periodically tighten all screws, bolts and nuts. A periodic inspection of all parts is necessary. If a part is broken or worn, replace immediately. For general maintenance please refer to our Playground Maintenance Manual.



IMPORTANT NOTES: Read First

(A) Use liquid thread lock (such as Loctite®) with all threaded hardware. **Important:** Liquid thread lock (prior to curing) helps to eliminate the common problem of "thread seizure" in stainless steel hardware by serving as a lubricant during assembly.

(B) This Assembly requires additional Assembly Pages. See also Assembly Page R5-09 Collars and R5-11 Socket Clamps.

(C) Collar Locations: Deck Mount - Collar measures 39" from top of deck to top of collar. Ground Mount - Collars measure 33-5/8" from top of lower collar to top of upper collar.

Under Deck Installation: Make sure distance between the bottom of the deck and the top of the panel(s) is less than 3-1/2" or greater than 9" to avoid head and neck entrapment.

(D) Use appropriate compliant protective surfacing and adjust footing depths accordingly. See free publication - The Handbook for Public Playground Safety, Publication #325 at www.CPSC.gov for the surfacing appropriate for the fall height of the equipment or consult you surfacing supply representative.

Assembly View

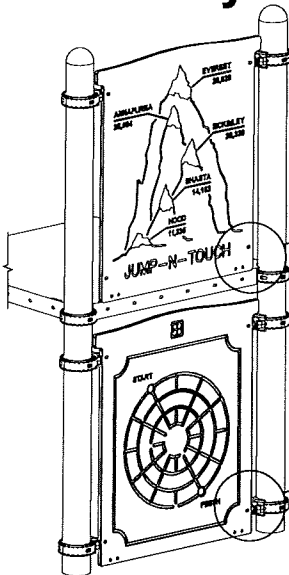

See Assembly Page R5-09 Collars and R5-11 Socket Clamps

See Figure 1
Panel to Deck Connection

See Figure 2
Mounting Lug Connection

Important: These assembly instructions apply to all R5 HDPE panels that deck and/or collar mount. Use specific panel instructions when available if installation requires different hardware and/or panel configurations other than shown in these instructions.

* Dimension given is from Top of Deck to Top of Collar

** Dimension given is from Top of Lower Collar to Top of Upper Collar

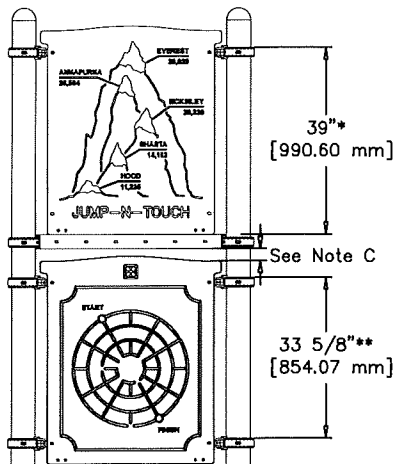

Elevation

Front View

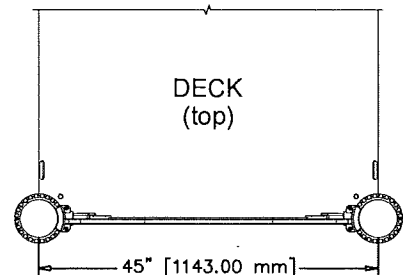

Post Spacing

Top View



Manufactured by Krauss Craft, Inc.
www.playcraftsystems.com

For Customer Service Call
800.333.8519 (U.S.A.) or
541.955.9199 (International)

H

PANEL - TYPE 2 (HDPE)

R5 - 1602
Page 3 of 3

Parts List - Deck Mount

<u>PART #</u>	<u>DESCRIPTION</u>	<u>QTY.</u>
-VARIES-	Panel (HDPE)	1
007007	Mounting Lug R5	2
007118	Flat Panel Bracket	2
See Pg. R5 - 11	Socket Clamp Assy.	2
9103052-TR	Bolt Button Head 3/8" x 1"	4
9103062-TR	Bolt Button Head 3/8" x 1-1/4"	2
9143062-TR	Shoulder Bolt 3/8" x 1-3/8"	2
9333002	Washer Flat 3/8" x 1" x .100 thick	8
9345002	Washer Flat 1/2" SAE	6
9413002	Nut Lock 3/8"	2
9443022-TR	Nut Barrel 3/8" x 5/8" BH	4

Parts List - Ground Mt.

<u>PART #</u>	<u>DESCRIPTION</u>	<u>QTY.</u>
-VARIES-	Panel (HDPE)	1
007007	Mounting Lug R5	4
See Pg. R5 - 11	Socket Clamp Assy.	4
9143062-TR	Shoulder Bolt 3/8" x 1-3/8"	4
9345002	Washer Flat 1/2" SAE	4

Specifications

PANEL:

Shall be fabricated using 3/4" High Density Polyethylene hot-extruded plastic.

SOCKET CLAMPS:

Shall be two-part and precision die-cast from a high strength aluminum alloy. The Socket Clamps have a multi-stage baked-on powder coat finish.

MOUNTING LUGS:

Shall be precision die-cast from a high-strength aluminum alloy. The Mounting Lugs have a multi-stage baked-on powder coat finish.

FLAT PANEL BRACKET:

Shall be precision laser-cut from 3/16" sheet steel. The Flat Panel Bracket has a multi-stage baked-on powder coat finish.

HARDWARE:

Shall be stainless steel, zinc/nickel plated or galvanized as required to resist rust and corrosion.

Installation

Step 1.

Locate and mark the position of the Collars on the Support Posts. Refer to Elevation View for Collar locations. See Note C. See also Assembly Page R5 - 09 Collars for hardware type and orientation.

Step 2. - Deck Mount

Attach the Panel to the deck using the Flat Panel Bracket. Refer to Figure 1 for hardware type and orientation.

Step 3.

Attach the Panel to the Post Collars using the Socket Clamps and Mounting Lugs. Refer to Figure 2 for hardware type and orientation. See also Assembly Page R5-11 Socket Clamps for additional hardware details.

Step 4.

Apply liquid thread lock and fully tighten all fasteners according to the "TIGHTENING TORQUE FOR HARDWARE" Section of the Installer's Manual. See Note A.

Step 5.

Place appropriate compliant protective surfacing under and around Ground Mounted Panels. See Note D.

Maintenance

Periodically tighten all screws, bolts and nuts. A periodic inspection of all parts is necessary. If a part is broken or worn, replace immediately. For general maintenance please refer to our Playground Maintenance Manual.



Manufactured by Krauss Craft, Inc.
www.playcraftsystems.com

For Customer Service Call
800.333.8519 (U.S.A.) or
541.955.9199 (International)

H

IMPORTANT NOTES: Read First

(A) Use liquid thread lock (such as Loctite®) with all threaded hardware. **Important:** Liquid thread lock (prior to curing) helps to eliminate the common problem of "thread seizure" in stainless steel hardware by serving as a lubricant during assembly.

(B) This Assembly requires additional Assembly Pages. See also Assembly Page R5-09 Collars and R5-11 Socket Clamps.

(C) Collar Locations : Collars measure 33-5/8" from top of lower collar to top of upper collar.
Under Deck Installation: Make sure distance between the bottom of the deck and the top of the panel(s) is less than 3-1/2" or greater than 9" to avoid head and neck entrapment.

(D) Use appropriate compliant protective surfacing and adjust footing depths accordingly. See free publication - The Handbook for Public Playground Safety, Publication #325 at www.CPSC.gov for the surfacing appropriate for the fall height of the equipment or consult you surfacing supply representative.

Assembly View

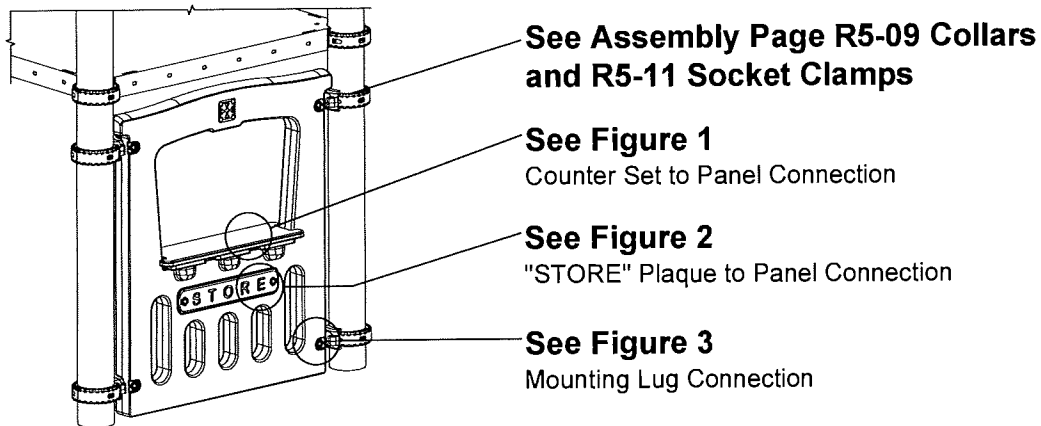

*Dimension given is from Top of Lower Collar to Top of Upper Collar

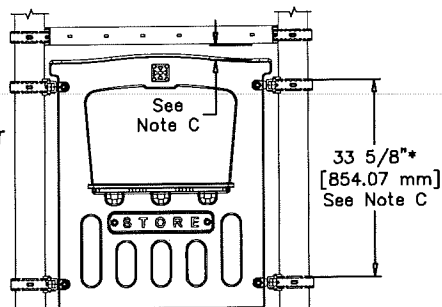

Elevation

Front View

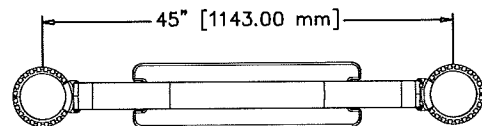

Post Spacing

Top View



Manufactured by Krauss Craft, Inc.
www.playcraftsystems.com

For Customer Service Call
800.333.8519 (U.S.A.) or
541.955.9199 (International)

Rev J

PANEL STORE ROTO

R5 - 1615
Page 3 of 3

Parts List

<u>PART #</u>	<u>DESCRIPTION</u>	<u>QTY.</u>
004785	Panel Store "Roto" Set (incl. Counter and Plaque)	1 Set
007007	Mounting Lug R5	4
123010	Panel Store Roto R5	1
See Pg. R5-11	Socket Clamp Assy.	4
9103062-TR	Bolt Button Head 3/8" x 1-1/4"	8
9103082-TR	Bolt Button Head 3/8" x 1-3/4"	4
9333002	Washer Flat 3/8" x 1" x .100 thk	12
9251032	Screw SQ #10 x 3/4" DR PH	12

Installation

Step 1.

Locate and mark the position of the Collars on the Support Posts. See Note C. Refer to Assembly Page R5-09 Collars for additional details and hardware.

Step 2.

Attach Counter Set to Panel. Refer to Figure 1 for hardware type and orientation. Attach "STORE" Plaque to front of Panel. Refer to Figure 2 for hardware type and orientation.

Step 3.

Loosely attach the top of the Panel to the Collars using Socket Clamps and Mounting Lugs. Refer to Figure 3 for hardware type and orientation. See also Assembly Page R5-11 Socket Clamps.

Step 4.

Repeat Step 3 to attach bottom of Panel to Collars.

Step 5.

Check distance between top of Panel and bottom of Deck to make sure it doesn't create an Entrapment. See Note C for details.

Step 6.

Apply liquid thread lock and fully tighten all fasteners according to the "TIGHTENING TORQUE FOR HARDWARE" Section of the Installer's Manual. See Note A.

Step 7.

Place appropriate compliant protective surfacing under and around Store Panel Roto. See Note D.

Specifications

STORE PANEL ROTO R5:

Shall be constructed of UV-stabilized, rotationally molded, Linear Low Density Polyethylene with an average single wall thickness of 1/4". The Panel (ROTO) shall be 38" x 43-1/2" x 3" deep.

COUNTER SET & "STORE" PLAQUE:

Shall be fabricated using 3/4" High Density Polyethylene hot-extruded plastic.

SOCKET CLAMPS:

Shall be two-part and precision die-cast from a high strength aluminum alloy. The Socket Clamps have a multi-stage baked-on powder coat finish.

MOUNTING LUGS:

Shall be precision die-cast from a high-strength aluminum alloy. The Mounting Lugs have a multi-stage baked-on powder coating.

HARDWARE:

Shall be stainless steel, zinc/nickel plated or galvanized as required to resist rust and corrosion.

Maintenance

Periodically tighten all screws, bolts and nuts. A periodic inspection of all parts is necessary. If a part is broken or worn, replace immediately. For general maintenance please refer to our Playground Maintenance Manual.



Manufactured by Krauss Craft, Inc.
www.playcraftsystems.com

For Customer Service Call
800.333.8519 (U.S.A.) or
541.955.9199 (International)

Rev J

IMPORTANT NOTES: Read First

- (A) Use liquid thread lock (such as Loctite[®]) with all threaded hardware. **Important:** Liquid thread lock (prior to curing) helps to eliminate the common problem of "thread seizure" in stainless steel hardware by serving as a lubricant during assembly.
- (B) Do not pour concrete until the equipment is completely assembled, leveled and plumbed. Concrete must be allowed to cure completely before using the equipment (at least 72 hours).
- (C) Refer to Installation Manual Section R5-1305 Double Sit Down Bar and R3.5-1305 Double Sit Down Panel.
- (D) Exit height must be between 7" [180mm] and 15" [380mm] from finish grade for slides with an elevation greater than 48". For slide elevations no greater than 48", the exit height shall be no greater than 11". Exit region must also have a downward slope of 0 to 4°.
- (E) Use appropriate compliant protective surfacing and adjust footing depths accordingly. See free publication - The Handbook for Public Playground Safety, Publication #325 at www.CPSC.gov for the surfacing appropriate for the fall height of the equipment or consult your surfacing supply representative.

FIGURE 1
60" Double Slide

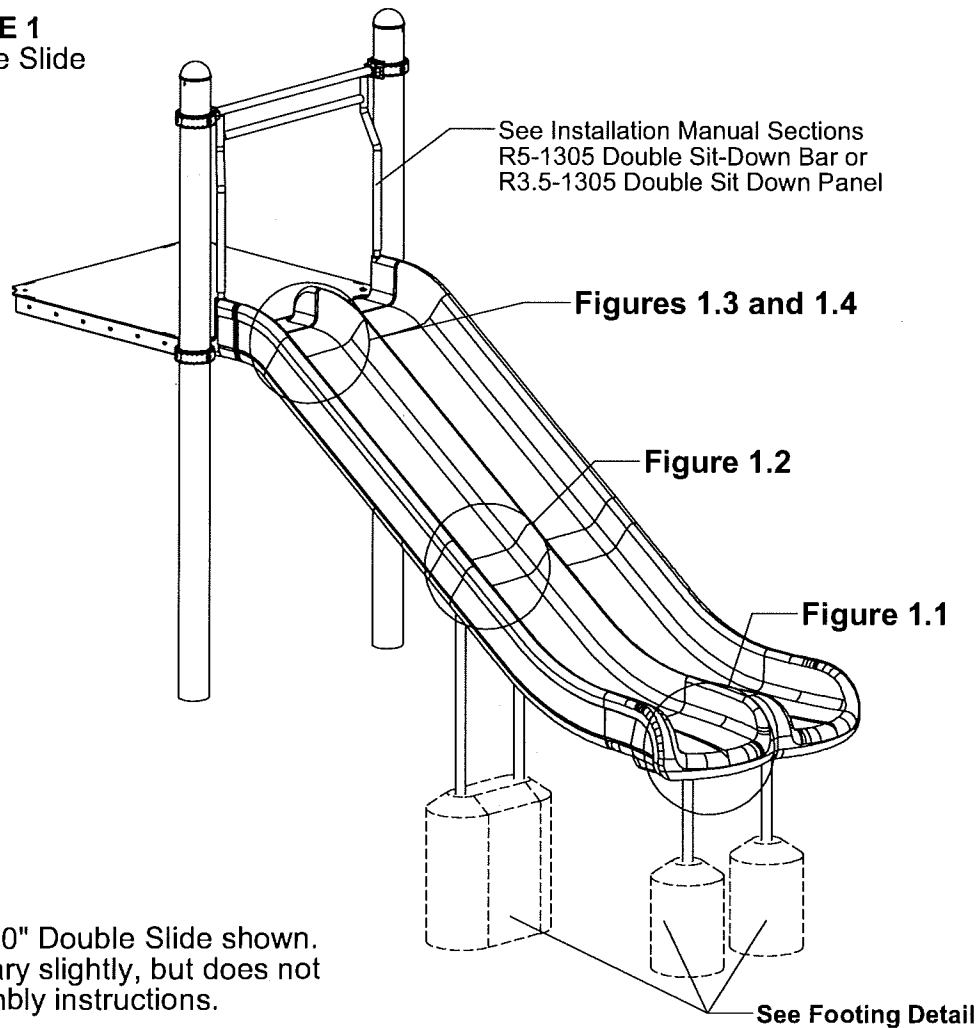

NOTE: R5 60" Double Slide shown.
R3.5 may vary slightly, but does not
affect assembly instructions.

R5 Top View - Footing Layouts

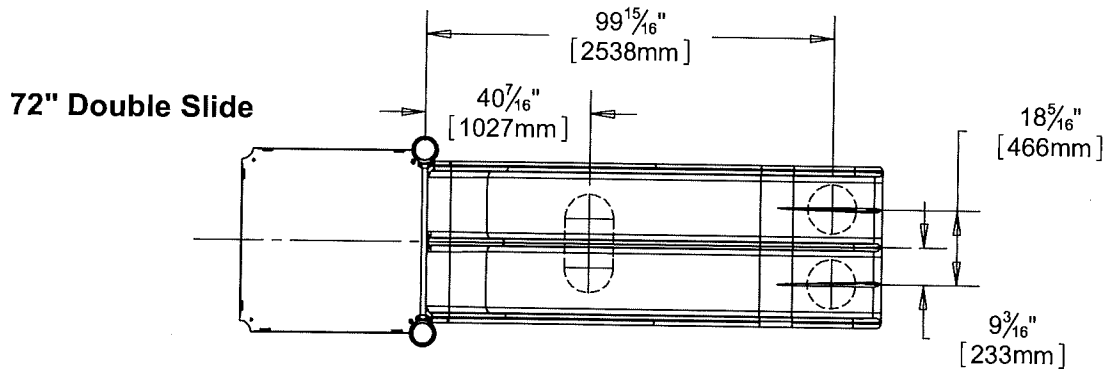
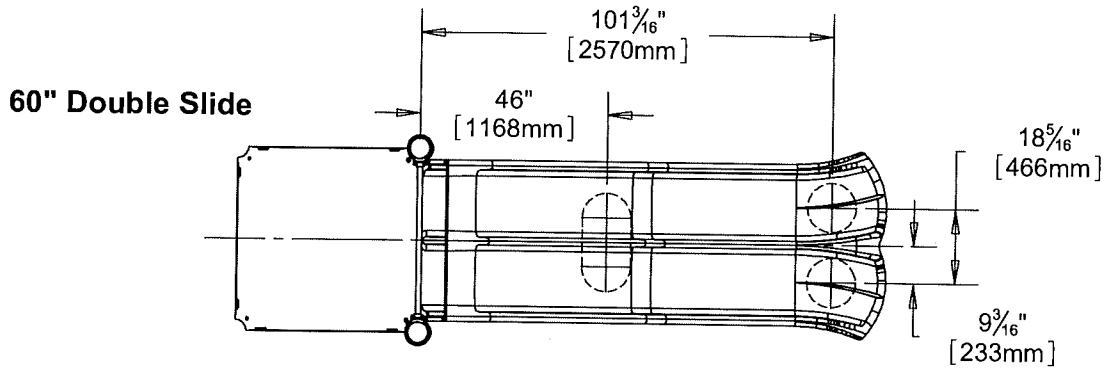
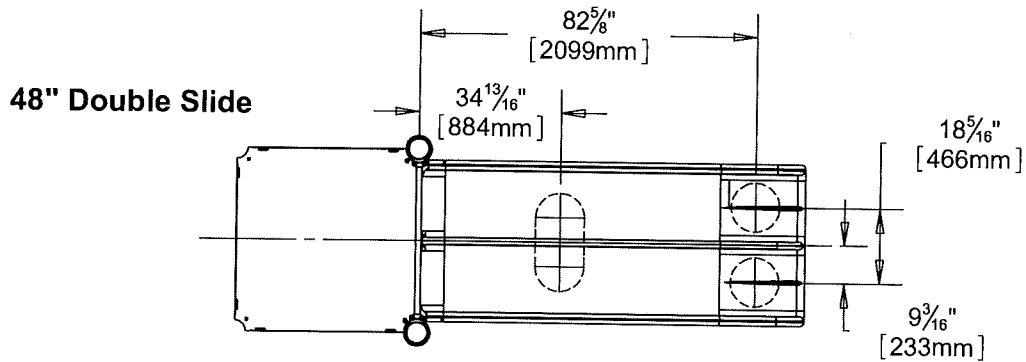
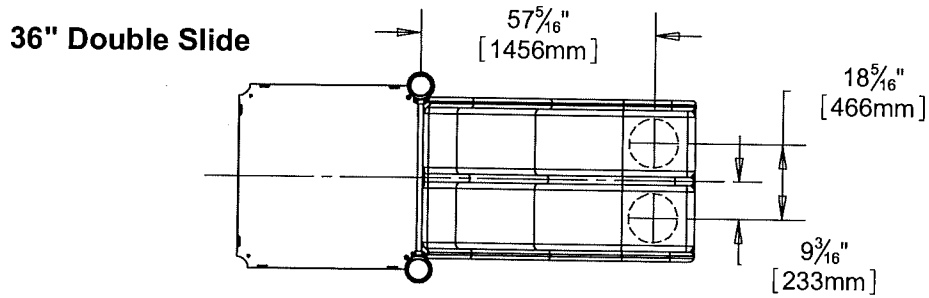

Step 2

Attach Double Slide Leg to the base of the double slide as shown in Figure 1.1. (See Note A)

Step 3

Note: This step does not apply to the 36" Double Slide. Attach slide supports to the double slide as shown in Figure 1.2. (See Note A)

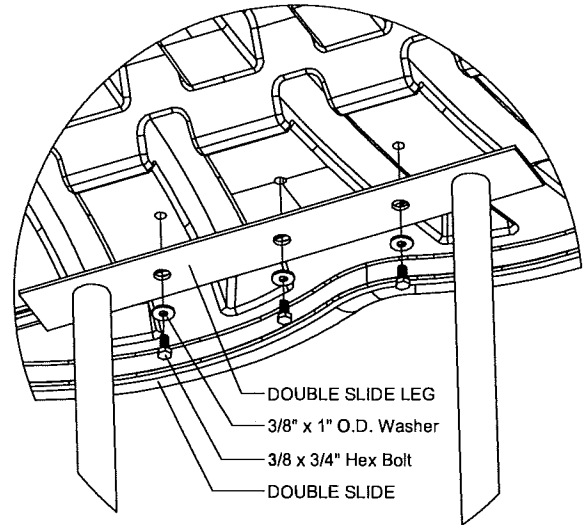

Figure 1.1

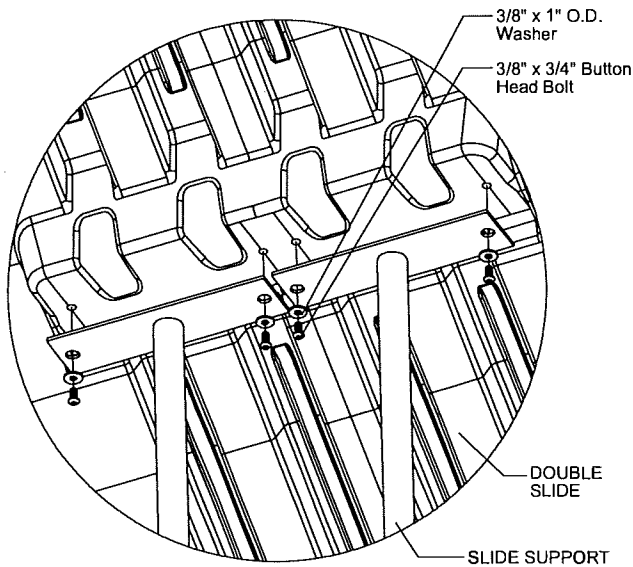

Figure 1.2

Step 4

For R5 Double Slide only

Place the Double Slide Leg and Supports into the footing holes and attach the face of the double slide to the face of the R5 deck as shown in Figure 1.3. (See Note A)

For R3.5 Double Slide only

Place the Double Slide Leg and Supports into the footing holes and attach the double slide and the R3.5 Double Slide Spacer to the face of the R3.5 deck as shown in Figure 1.4. (See Note A)

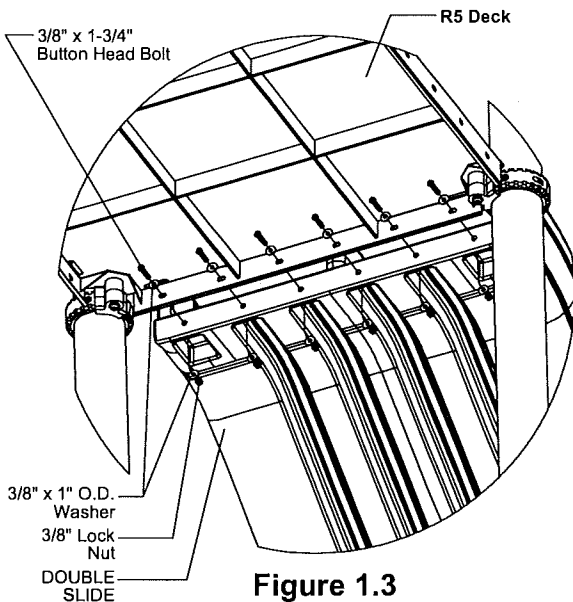

Figure 1.3

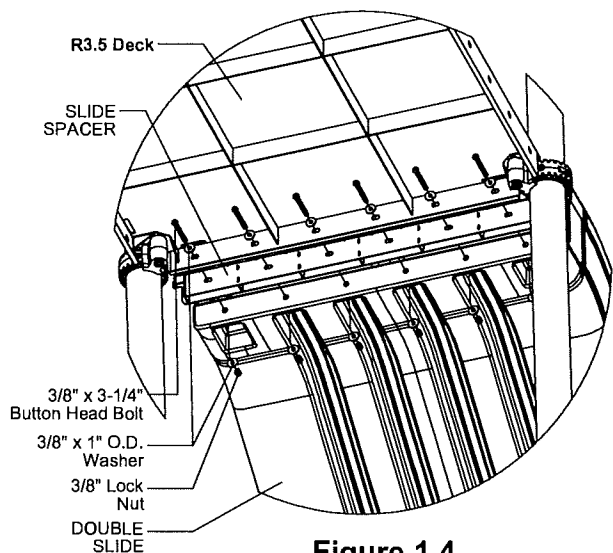

Figure 1.4

DOUBLE SLIDE

1702
Page 7 of 7

60" Double Slide

R5 Parts List		
Part #	DESCRIPTION	QTY.
DE-4806	60" Double Slide	1
FS-1702	Double Slide Leg	1
FS-1704	Wave Slide Support	2
9103032-TR	Bolt Button Head 3/8" x 3/4"	4
9103082-TR	Bolt Button Head 3/8" x 1-3/4"	6
9123032	Bolt Hex 3/8" x 3/4"	3
9333002	Washer Flat 3/8" x 1" O.D. x .100" thick	19
9413002	Nut Lock 3/8"	6

R3.5 Parts List		
Part #	DESCRIPTION	QTY.
CG-8128	Slide Spacer R3.5	1
DE-4806	60" Double Slide	1
FS-1702	Double Slide Leg	1
FS-1704	Wave Slide Support	2
9103032-TR	Bolt Button Head 3/8" x 3/4"	4
9103142-TR	Bolt Button Head 3/8" x 3-1/4"	6
9123032	Bolt Hex 3/8" x 3/4"	3
9333002	Washer Flat 3/8" x 1" O.D. x .100" thick	19
9413002	Nut Lock 3/8"	6

72" Double Slide

R5 Parts List		
Part #	DESCRIPTION	QTY.
DE-4324	72" Double Slide	1
FS-1702	Double Slide Leg	1
FS-1704	Wave Slide Support	2
9103032-TR	Bolt Button Head 3/8" x 3/4"	4
9103082-TR	Bolt Button Head 3/8" x 1-3/4"	6
9123032	Bolt Hex 3/8" x 3/4"	3
9333002	Washer Flat 3/8" x 1" O.D. x .100" thick	19
9413002	Nut Lock 3/8"	6

R3.5 Parts List		
Part #	DESCRIPTION	QTY.
CG-8128	Slide Spacer R3.5	1
DE-4324	72" Double Slide	1
FS-1702	Double Slide Leg	1
FS-1704	Wave Slide Support	2
9103032-TR	Bolt Button Head 3/8" x 3/4"	4
9103142-TR	Bolt Button Head 3/8" x 3-1/4"	6
9123032	Bolt Hex 3/8" x 3/4"	3
9333002	Washer Flat 3/8" x 1" O.D. x .100" thick	19
9413002	Nut Lock 3/8"	6

Maintenance

Periodically tighten all screws, bolts and nuts. A periodic inspection of all parts is necessary. If a part is broken or worn, replace immediately. For general maintenance please refer to our Playground Maintenance Manual.



Manufactured by Krauss Craft, Inc.
www.playcraftsystems.com

For Customer Service Call
800.333.8519 (U.S.A.) or
541.955.9199 (International)

Rev E
7/18/2009

HEX ROOF ASSEMBLY

R5-1803

Page 1 of 3

Assembly View

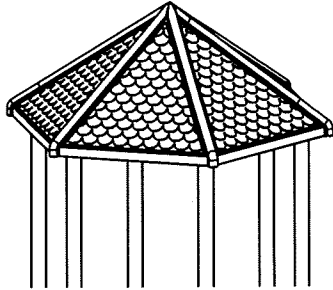
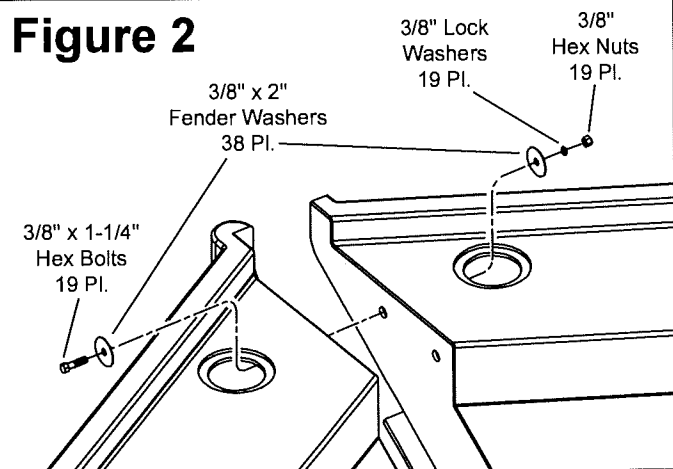

Figure 2



Access Holes
See Figures 2 & 3

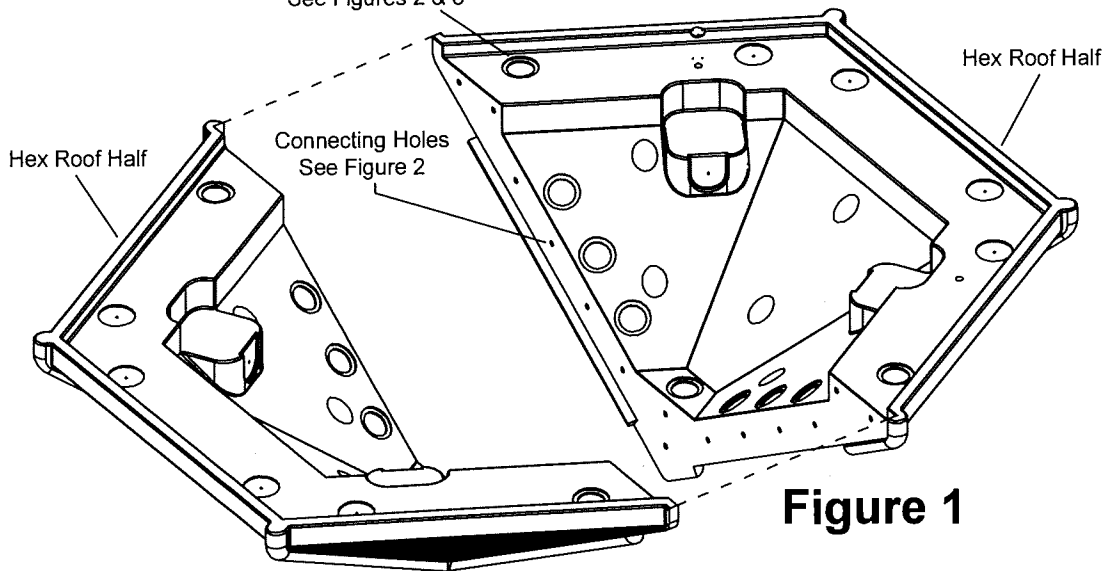

Figure 1

Figure 3

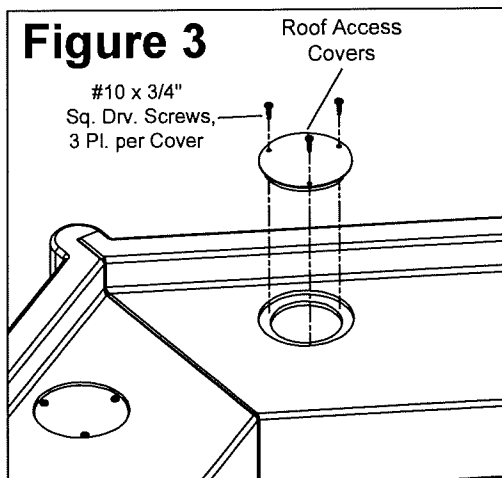
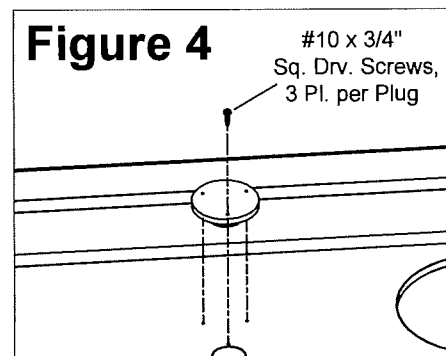

Figure 4



HEX ROOF ASSEMBLY

R5-1803

Page 3 of 3

Parts List

<u>QTY.</u>	<u>DESCRIPTION</u>	<u>PART #</u>
2	Hex Roof Halves	4308
18	Roof Access Covers #2	4449
4	Roof Hole Plug	4450
6	Roof Casting 2-Ear (R5)	7163
12	3/8"x1-1/2" Button Hd. Bolts	9103072-TR
14	3/8"x1-1/4" Hex Bolts	9123061
12	#12x1-1/2" Sq. Drv. Screws	9221272
66	#10x3/4" Sq. Drv. Screws	9251032
12	1/4"x1-1/4" Sq. Drv. Tek Screws	9271060
28	3/8"x2" Fender Washers	9323091
12	3/8" Washers	9333002
14	3/8" Lock Washers	935302P
14	3/8" Hex Nuts	9483601
12	3/8" Strap Toggle Fasteners	9643160

Specifications

ROOF:

Shall be roto-molded of UV-stabilized polyethylene with an average wall thickness of .250".

ROOF BRACKET:

Shall be precision die-cast from a high strength aluminum alloy. finished with a baked on powder coating.

HARDWARE:

Shall be stainless steel as required to resist rust and corrosion.

ACCESS COVERS / HOLE PLUGS:

Shall be HDPE 1/2" (high-density color plastic).

Maintenance

Periodically tighten all screws, bolts and nuts.
A periodic inspection of all parts is necessary.
If a part is broken or worn, replace immediately.

Installation

Notes:

(A) Use Posts *without* caps.

(B) Snug tighten all fasteners during assembly. After assembly, check position and tighten the fasteners fully.

(C) Use liquid thread lock (such as Loctite) with all threaded hardware. **Important:** Liquid thread lock (prior to curing) helps to eliminate the common problem of "thread seizure" in stainless steel hardware by serving as a lubricant during assembly.

* (D) Caution must be given to Toggle assembly as parts may become fragile during insertion and final securing.

Step 1.

Join (2) Hex Roof Halves as shown in Figures 1 & 2.

Step 2.

Attach (18) Roof Access Covers as shown in Figure 3.

Step 3.

Attach (4) Roof Hole Plugs as shown in Figure 4.

Step 3.

Place the (6) Roof Support Castings over the Posts and align them as shown in Figure 5.

Step 4.

Position & Center the assembled Hex Roof on the Roof Support Castings.

Step 5.

Mark Roof Support Casting hole positions on Hex Roof.

Step 6.

One at a time, move Roof Support Castings out of position and match drill (2) 3/4" Dia. holes at each casting location. Cinch the (4) Strap Toggle Fasteners into the roof through the 3/4" holes. See Figure 6. Reposition Roof Castings.

Step 7.

Check the Roof Casting alignment & drive (2) #12x1-1/2" Sq. Drive Screws thru the Small holes in the top of each Roof Bracket and into the underside of the Roof. See Figure 6.

Step 8.

Complete the attachment of the Roof to the Roof Castings using the Button Head Bolts and washers as shown in Figure 6.

Step 9.

Drive (2) opposing Tek Screws thru the sides of each Roof Support Casting and into Posts. See Figure 6.

Step 10.

Fully tighten all fasteners.



Manufactured by
Krauss Craft, Inc.

Phone: 800.333.8519

Rev. H

IMPORTANT NOTES: Read First

(A) Use liquid thread lock (such as Loctite®) with all threaded hardware. **Important:** Liquid thread lock (prior to curing) helps to eliminate the common problem of "thread seizure" in stainless steel hardware by serving as a lubricant during assembly.

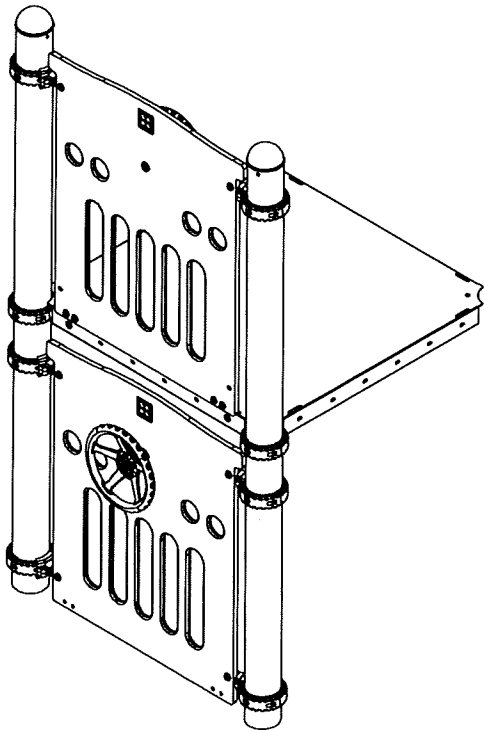

FIGURE 1
Driver Wheel To Panel

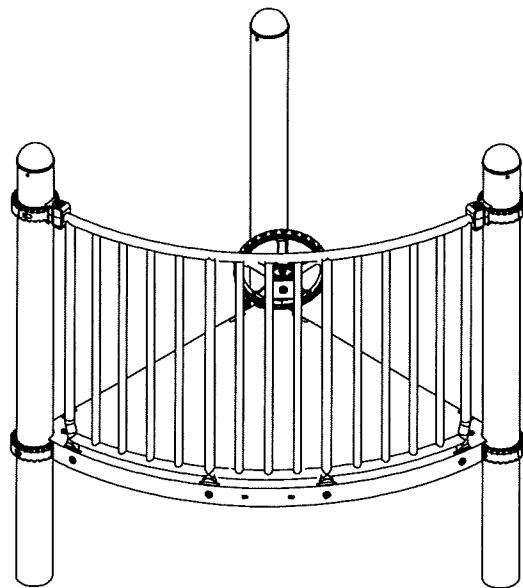

FIGURE 2
Driver Wheel To Wall

NOTE: Figures shown are to represent Driver Wheel Assembly to Panel and Driver Wheel Assembly to Wall. Other Panels and Walls may vary slightly but do not affect assembly



Manufactured by Krauss Craft, Inc.
www.playcraftsystems.com

For Customer Service Call
800.333.8519 (U.S.A.) or
541.955.9199 (International)

Rev I
10/1/2009

Step 1b

For Driver Wheel To Wall Only:
Attach the Driver Wheel Casting to Steel Walls with the hardware shown in Figure 4. (See Note A)

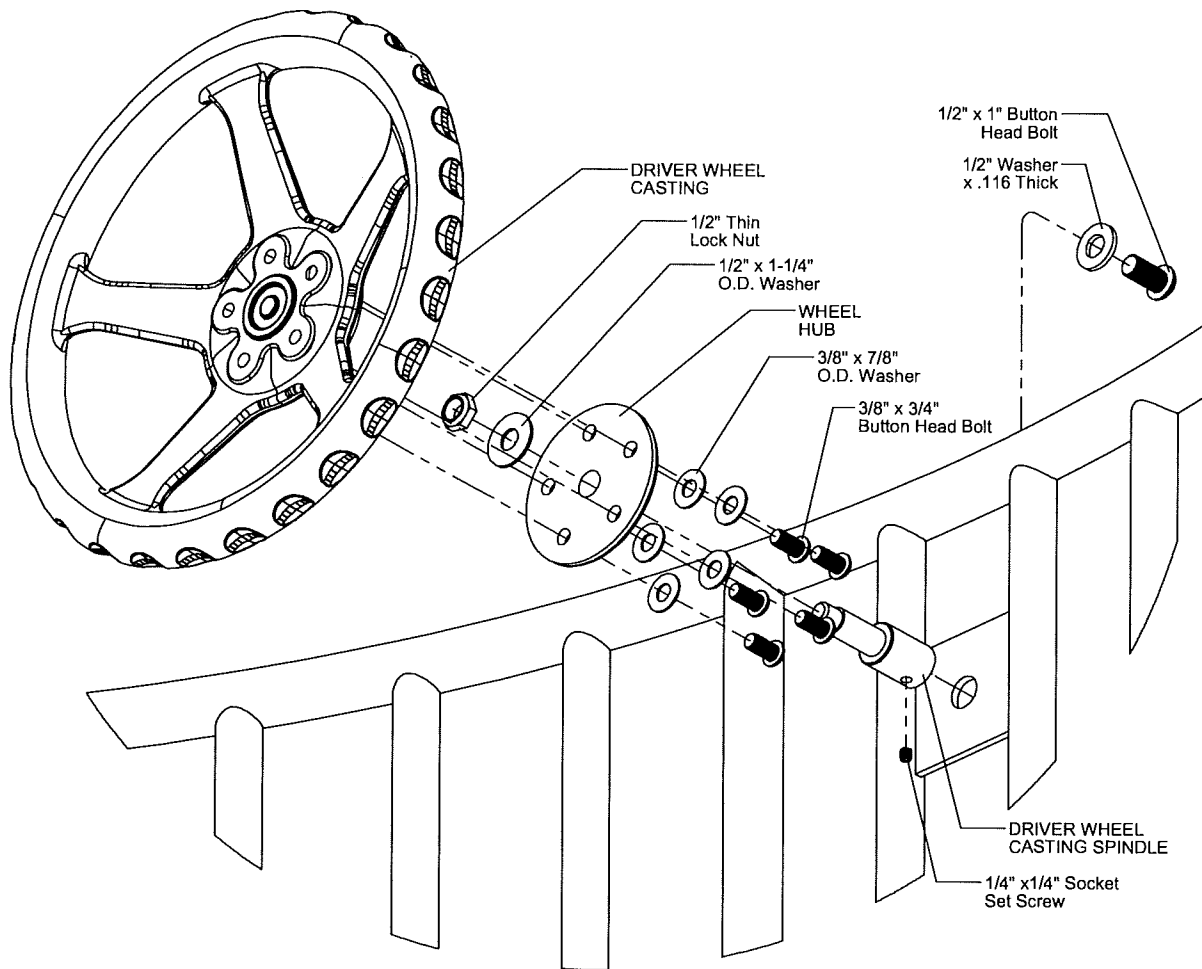

FIGURE 4



The advertisement shows a large playground structure with multiple slides and platforms. In the foreground on the left, there is a cover for the 'PLAYCRAFT 2011' catalog, which features a photograph of children playing. Below the playground image, there is a call to action: 'CLICK HERE TO VIEW OR REQUEST A CATALOG'. To the left of this text are links for 'Links', 'About Us', and 'Contact Us'. To the right is a 'SHARE' button with icons for Facebook, Twitter, and email. At the bottom, a dark banner contains the text: 'Call 1-800-333-8519 for a free copy of our Playcraft Playground Equipment Catalog!'. On the far left, there is a small, partially visible text fragment: 'ditions of use. For view using a resolution of 1024x768 pixels. Higher.'



PLAY FOCUSED SOLUTIONS

BETTER SOLUTIONS FOR TODAY'S RECREATION



[Home](#)
[Service](#)
[Playgrounds](#)
[New Items](#)
[Current Offers](#)
[Projects](#)
[Contact Us](#)
[Request a Catalog](#)

Current Onsite Photo



Community-Built



Current Mailer

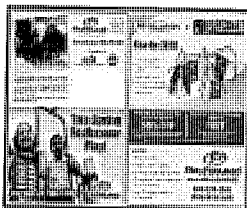

New!



Welcome!!

From the beginning our focused commitment to Wisconsin has been to provide safe, fun, and quality commercial play equipment. We serve the commercial recreation needs of schools, municipalities, developers, and the like. We look forward to working with you on your next project.

Sincerely,
 Andy Peters, owner
 608-220-6501

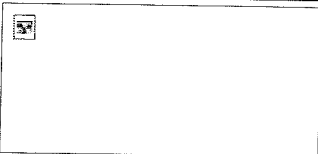
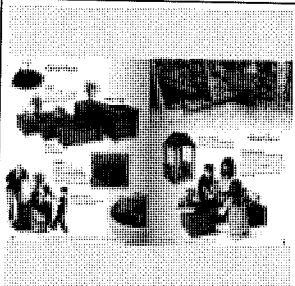

View our online catalogs

Playcraft	Playmart-Nature at Play
 <p>Open publication - Free publishing - More park</p>	

Request a free catalog with pricing and promotions

Play Focused Solutions, LLC Toll Free 866-414-8220

Important ! Please Read Completely Before Beginning Installation. According to a report published by the U. S. Consumer Product Safety Commission (C.P.S.C.) 72% of all playground injuries result from accidental falls. With this in mind, this equipment is designed to fill the need for safe yet challenging play. In conjunction with design efforts to reduce the possibilities of injuries, this equipment **must** be installed "Step by Step" per our installation instructions. As a new owner you are responsible for the correct installation, safe use, and maintenance of your equipment.

Installation Guidelines

- Identify all parts and thoroughly read the assembly instructions before beginning construction.
- Refer to your playground equipment plan and footing diagram to assure the equipment purchased will fit into your selected site area. The use and no-encroachment zones around the play equipment shall be obstacle-free areas designated for unrestricted circulation.

(ASTM / CSA)

- For belt and rigid swing seats, the use zone for swing equipment should extend to the front and rear of a single axis swing a minimum distance of twice the height measured from the pivot point above the surfacing material measured from a point directly beneath the pivot on the supporting structure. The use zone on the sides of the swing should extend a minimum of 72 inches (1829 mm). A no-encroachment zone is also required for installations in areas overseen by the Canadian Standards Association (C.S.A.). In addition to the use zone measurement on both sides of the top rail, this zone will extend an additional 72 inches (1829 mm) and may **not** be overlapped by the use or no-encroachment zones of adjacent play equipment. See diagram.
- For enclosed infant swing seats, the use zone for swing equipment should extend to the front and rear of a single axis swing a minimum distance of twice the measurement from the pivot point to the swing seat surface measured from a point directly beneath the pivot on the supporting structure. The use zone on the ends of the swing (support structure) should extend a minimum of 72 inches (1829 mm). A no-encroachment zone is also required for installations in areas overseen by the Canadian Standards Association (C.S.A.). In addition to the use zone measurement on both sides of the top rail, this zone will extend an additional 72 inches (1829 mm) and may **not** be overlapped by the use or no-encroachment zones of adjacent play equipment. See diagram.

Belt/Rigid Seat Swing Zones (ASTM/CSA)

- A =** Side Use Zone
72 in. (1829 mm)
- B =** End Use Zone
Height of Pivot Point
from Surfacing x 2
Both Sides of Top Rail
- C =** No-encroachment Zone
72 in. (1829 mm)

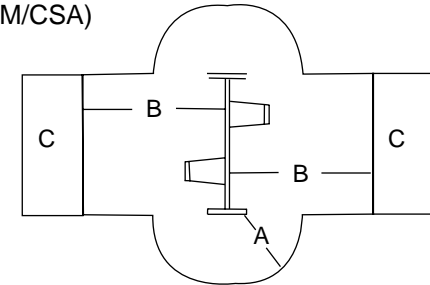

- The use zone on either end of the swing (72 inches [1829 mm]) may be overlapped by the use zone on either end of the another swing (72 inches [1829 mm]). Swing zones on either side of the top rail may **not** be overlapped by the use zones of other play equipment.

Infant Seat Swing Zones

- A =** Side Use Zone
72 in. (1829 mm)
- B =** Distance from Pivot Point
to Swing Seat Surface
- C =** End Use Zone: B x 2
Both Sides of Top Rail
- D =** No-encroachment Zone
72 in. (1829 mm)

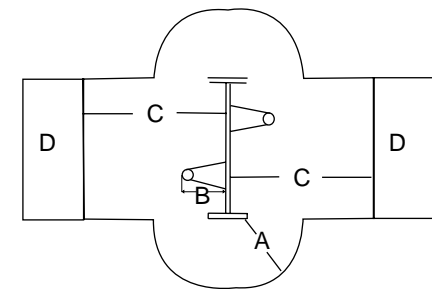

Installation Instructions

(EN)

• For areas conforming to the EN-1176 Standard, the impact area shall be determined by calculating the horizontal distance where the swing seat is at an 60° arc and adding the appropriate amount of distance based upon the type of protective surfacing. This distance shall be covered by protective surfacing on both sides of the top rail. The protective surfacing shall be appropriate for the maximum fall height of the swing. There is no difference in the calculation based on the type of swing seat.

The impact area on both sides of top rail = $(0.867 \times \text{Distance from pivot point to seat}) + \text{either } 1750 \text{ mm if unitary surfacing or } 2250 \text{ mm if loose-fill surfacing is used. There shall be a minimum corridor of } 1750 \text{ mm centered on each swing seat for the length of the impact area.}$

Use Zones - EN Compliance

A = Width of the corridor centered on the swing seat
1750 mm

B = Length of the use zone on both sides of the top rail (8ft)
Tot Seats: 3290 mm for unitary surfaced areas
or 3790 mm for areas covered with loose fill surfacing.
Belt / Rigid Seats: 3510 mm for unitary surfaced areas
or 4010 mm for areas covered with loose fill surfacing

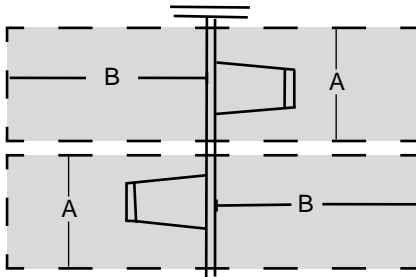

- Site layout is a critical part of the overall installation. Footings must be measured and marked accurately according to the footing diagram. A level and clear installation site is ideal.
- Good drainage around the structure and its supports is important. Inquire with local contractors for appropriate recommendations.
- After laying out all footings and before digging holes, be sure to inquire about underground utilities that may exist.
- Do not leave the job site unattended without making sure that all fastening hardware on all components are tightened according to tightening torque specifications listed on every installation guide. We also recommend roping off construction area and covering all holes that do not contain a piece of equipment with plywood or other suitable material.
- Excavate holes as shown in the footing detail. If a level and clear site cannot be obtained, adjust the depth of footing to maintain a level footing base. If soil conditions are loose or unstable, a larger diameter footing may be required. Inquire with local contractors for appropriate recommendations. Be sure concrete that might have splashed onto the unit is washed off before it dries. Allow concrete to harden 72 hours before allowing your structure to be used. **Assemble the entire structure before pouring concrete unless specifically instructed to do so in the installation instructions.**
- Insure that hard surface warning/Playworld Systems identification labels are properly affixed to the play equipment. Labels are to be plainly visible according to current playground equipment guidelines.
- **IMPORTANT!** Because accidental falls around your playground equipment can occur, Playworld Systems recommends that the area under and around the structure be covered with a resilient material such as sand, bark mulch, or wood chips. If loose fill surfacing materials are used, Playworld Systems recommends a depth of 12 in. (305 mm). An approved rubber safety matting can also be used. **Many protective surfacing materials can become compacted due to weather and use, which reduces their shock absorbency. It is strongly recommended that the surfacing be checked weekly and material added or replaced as necessary. Hard surfaces, such as asphalt, concrete and packed earth are not acceptable for use under playground equipment.**

Installation Instructions

- The entire area, under and around the playground equipment, must be covered with protective surfacing material. The impact attenuation of the protective surfacing under and around playground equipment should be rated to have a critical height value of at least the height of the highest accessible part of the equipment. The critical height for surfacing is to be rated in accordance with A.S.T.M. standard, designated F1292, [A Standard Specification for Impact Attenuation of Surface Systems Under and Around Playground Equipment](#). Contact the manufacturer of unitary surfacing materials (rubber matting) for the critical height rating for their products.

Tools Required: Playworld Systems supplies a service kit that contains commonly used hex key wrenches required to assemble your equipment. You may also need: shovel, digging iron, post hole digger, steel rake, wheelbarrow, garden hoe, water hose, tape measure, level, alignment tool, 3/8" ratchet with 9/16" socket, and 9/16" combination wrench.

Maintenance

- Inadequate maintenance of equipment has resulted in injuries on the playground. Because the safety of playground equipment and its stability depends on good inspection and maintenance, **a comprehensive maintenance program must be developed for each playground and strictly followed.** All equipment must be inspected frequently for any potential hazards. Special attention must be given to moving parts and other components that can be expected to wear. Inspections must be carried out in a systematic manner by trained personnel. Any damaged or worn parts, or any other hazards identified during inspections must be repaired or replaced immediately. Complete documentation of all maintenance inspections and repairs must be retained.

Supervision Guidelines

- Playworld Systems strongly recommends close supervision of the children as they play as well as intensive classroom and home instruction about safe behavior on playground equipment.
- Playground supervisors should be aware that not all playground equipment is appropriate for all children who may use the playground. Signs should be posted near the equipment indicating the recommended age of the users. Supervisors should direct children to equipment appropriate for their age.
- It is important that playground supervisors recognize that preschool-age children require more attentive supervision on playgrounds than older children.
- Do not permit the use of wet playground equipment. Wet equipment will inhibit necessary traction and gripping capabilities. Slips or falls could occur.
- Do not permit too many children on the same piece of equipment at the same time. It is suggested that children take turns.
- Constantly observe play patterns to discover possible hazardous play and suggest changes in equipment use or play patterns.

Installation Instructions

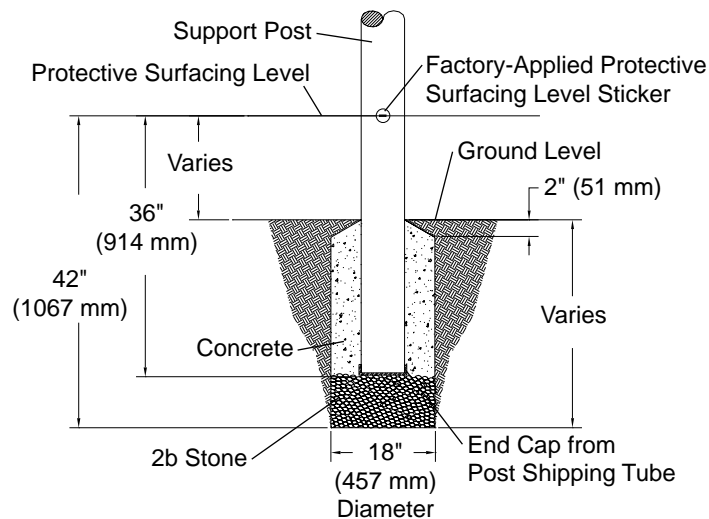

Support Post Footing Detail (ASTM/CSA)

FOOTING NOTES

- Support post footing depth equals 42 in. (1067 mm) less the depth of the protective surfacing material. The post is designed to have 24" (610 mm) in concrete.
Example: If 12 in. (305 mm) of wood mulch is used for surfacing, the footing depth would be 30 in. (762 mm).
- All support posts and component support legs shall have either a factory-applied sticker with line, or factory-applied mark designating protective surfacing level on a clear and level installation site.
- If play structure is installed on uneven terrain, maintain support post mark at protective surfacing level at lowest grade. Adjust other footings accordingly. Support posts and all attaching decks and play components must be plumb and level.
- Do not encase bottom of support post in concrete. Place post directly on packed stone.
- The footings shown on Playworld Systems' documentation are recommendations based on historical performance in average soil conditions. Footing dimensions may be modified by the owner based on actual soil conditions.
For example:
 - If local soil is loose or unstable, a larger footing may be required.
 - If local soil is considered stable, such as bedrock, clay or hard packed earth, a smaller footing may be used. Before changing footing dimensions, we strongly recommend that the footings be reviewed and approved by a registered engineer.
- Base of footing must be below frost line.
- Assemble the entire structure before pouring concrete unless specifically instructed to do so in the individual component installation instructions.

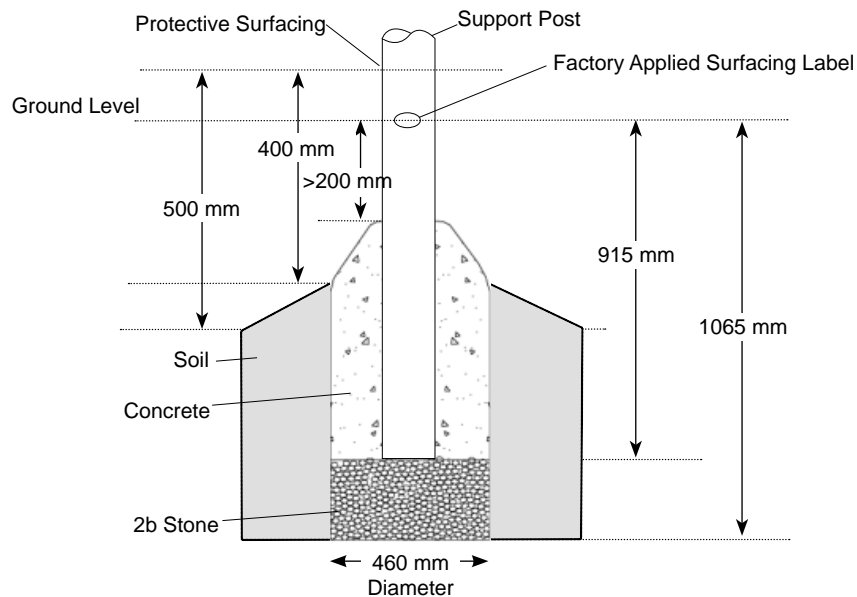

Footing Detail Support Post (EN)



PLAYWORLD SYSTEMS®

The world needs play.™

Installation Instructions

Playworld Systems® Model XX0370
 5 in. (127 mm) O.D. Aluminum Arch Swing
 2-Unit Add-A-Bay

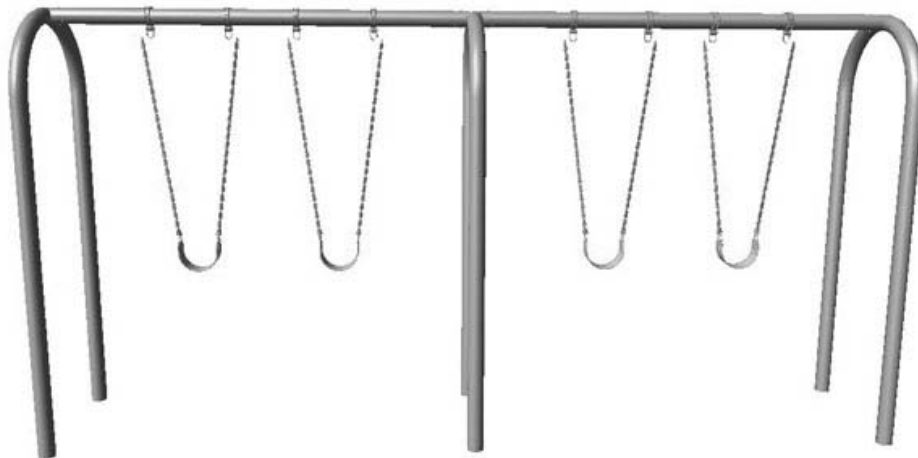

Assembly View

Installation Preparation

Recommended Crew: Three (3) adults
 Installation Time: 2 man-hours
 Weight: *156.2 lbs. (70,3 kg)
 Concrete Required: 0.24 cubic yard (0,18 cubic meters)
 Use Zone: Refer to Master Drawing
 User Group Age (years): ASTM/CSA: 2-12, EN: 2-14

**Weights are approximate for determining manpower.*

ICON KEY			
	Fully Tighten Hardware		Add 1 Drop of Thread Locking Adhesive
	Do Not Fully Tighten Hardware		Pour Concrete
	Drill		Dig Footing Holes
	Hammer		Critical Fall Height



Installation Instructions

KEY	
Position	Unit of Measurement
Top #	Inches
Bottom #	[Millimeters]

Top View

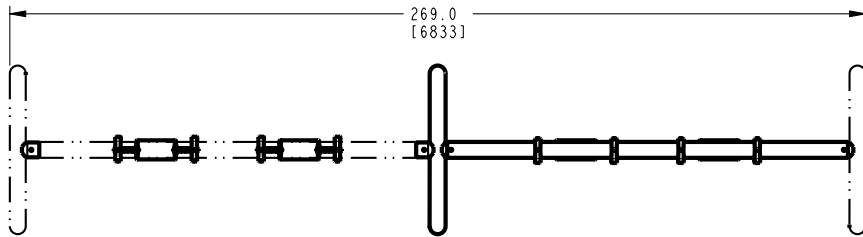

Note: Swing Hanger locations are dimensioned from end of the Top Rail to center of Swing Hanger.

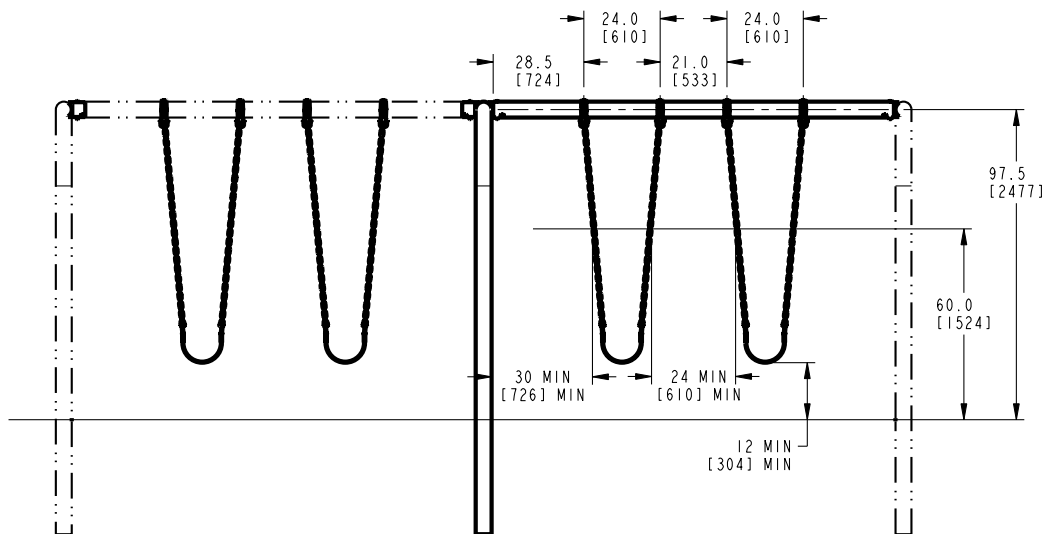

Elevation Views

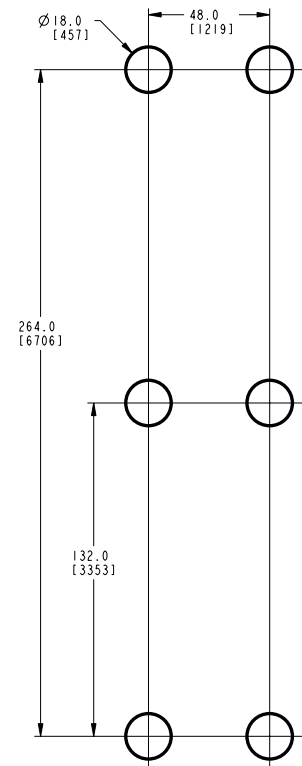

Footing Diagram

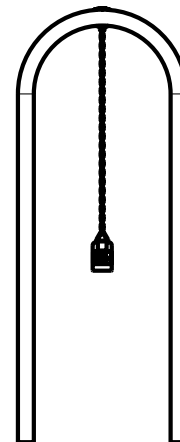

Installation Instructions

Follow the details in alphabetical order. For clarification, each detail references the step description. The step descriptions start on page 9.

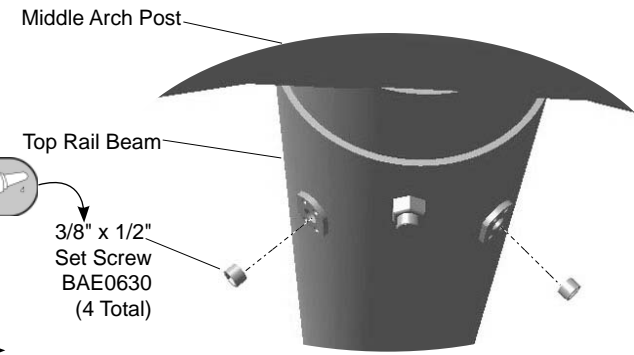
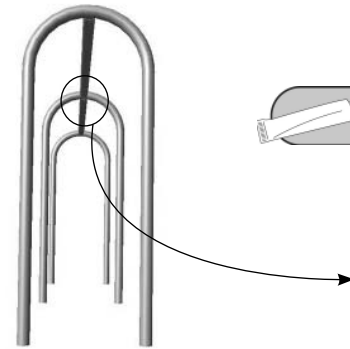
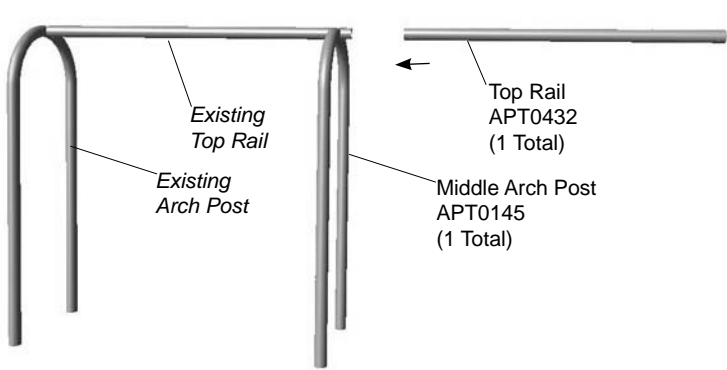

Detail B Step 7

Secure the top rails to the middle arch post.

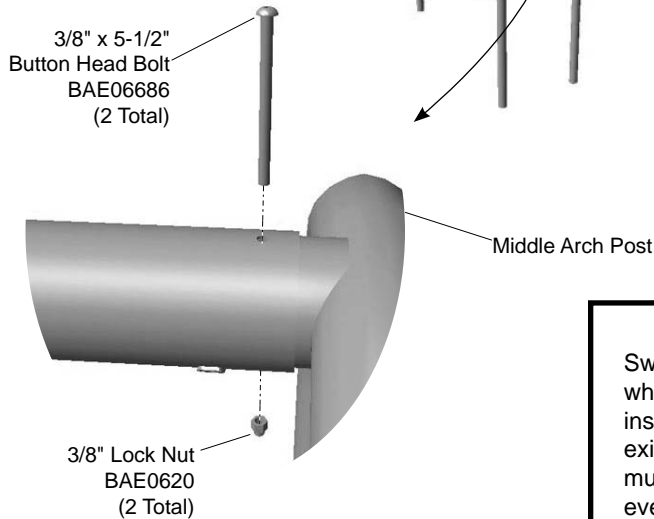

Detail A Step 5

Attach both top rails (new and existing) to the middle arch support.

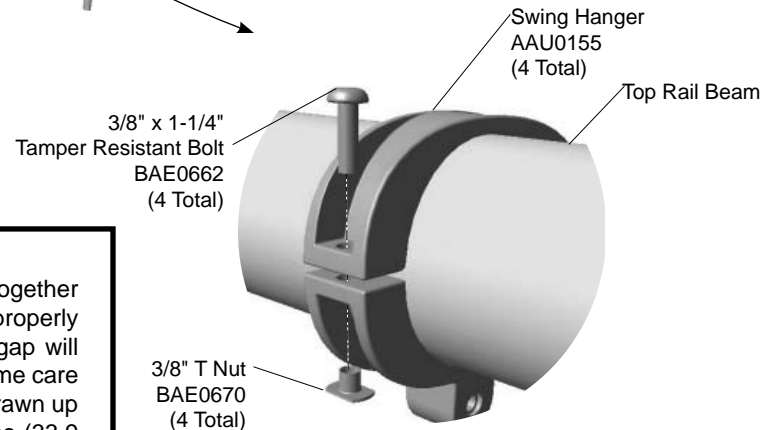
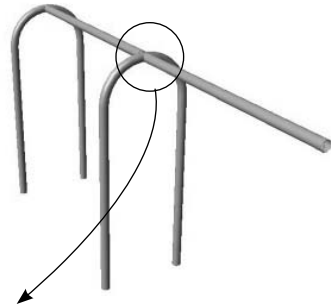

When tightening the bolt ensure that the T nut does not protrude past the edge of the clamp.

Detail C Step 10

Attach swing hangers to the top rail.



CAUTION

Swing hangers cannot be completely drawn together when attaching to the swing top rail. When properly installed, a gap of approximately 1/8" (3 mm) gap will exist between the swing hanger castings. Extreme care must be taken that nuts on swing hangers are drawn up evenly. Do **NOT** over tighten or exceed 25 ft lbs (33.9 Nm) of torque.

Warning!

Exceeding 25 ft lbs (33.9 Nm) of torque on the swing hanger bolts may cause damage to the swing band.

Installation Instructions

Swing Hanger

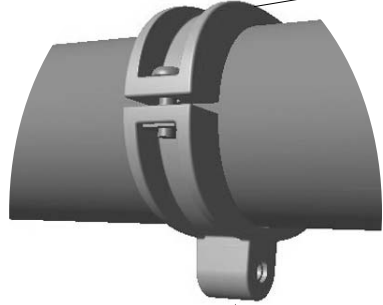

Swing Clevis Connector
ABC0704
(4 Total)

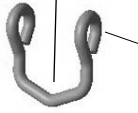

Swing Clevis Connector
ABC0704
(4 Total)

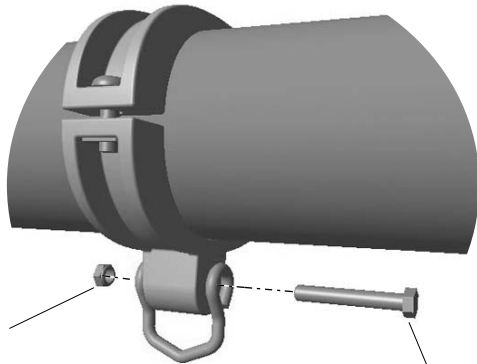

3/8" Thin Series Lock Nut
BAE0610
(4 Total)



Detail D
Step 11

Attach each clevis to a swing hanger.

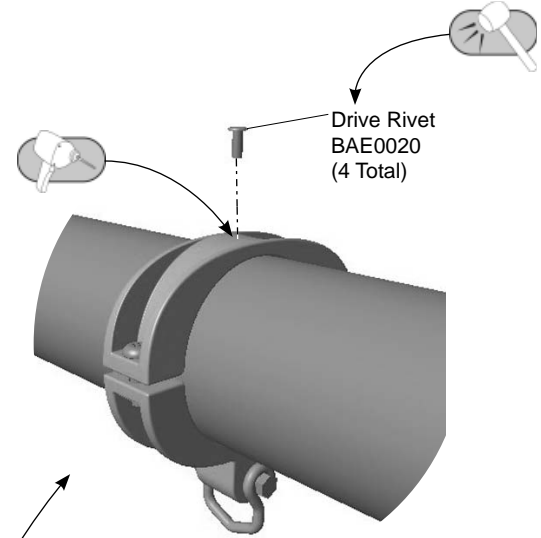
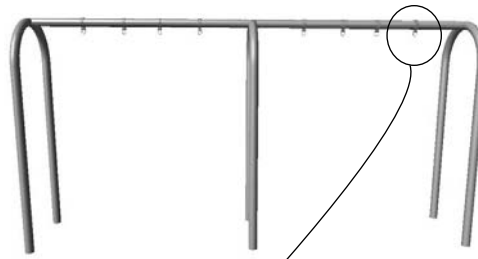

Drive Rivet
BAE0020
(4 Total)

Detail E
Step 14

*Secure the swing hangers
to the top rail.*



Installation Instructions

Notes Before You Begin: Do not over tighten bolts during assembly, only snug tighten them until assembly is complete.

Carefully read and understand these installation instructions before you begin.

Step 1: Before attempting to assemble your equipment, please review all installation information carefully. Should you experience any difficulty during the installation process, please call us at the phone number shown on the last page of these instructions.

Step 2: Separate and identify all components and hardware.

Step 3: Prepare footings as shown in the **Support Post Details** on **Page 4**.

Existing Swing

Step 4: Applies to adding an additional bay to a pre-existing product, remove (1) one of the existing arch supports by unscrewing and removing the connection to the top rail. Dig around the footing of the support post and transplant it to the opposing end of the bay addition as shown in the **Footing Diagram**. After completing, proceed to **Step 5**.

New Installation

Assemble the swing frame.

Step 5: Attach both top rails (new and existing) to the middle arch support. See **Detail A**. Select the top rail, the middle arch support, and the appropriate hardware. There are (2) two connections. Place the middle arch support in the excavated footings and brace. Place the top rail onto the arch stub and align holes. Attach as shown.

Re-Connect opposite end of frame.

Step 6: Re-attach arch support to opposite end of frame using existing hardware. Refer to the documentation that came with your original swing frame.

Step 7: Secure the top rails to the arch posts. See **Detail B**. Apply a drop of loctite to the set screw threads and thread each screw into a hole on the underside of the post stub. Fully tighten connections according to tightening torque specifications.

Torque Specifications:

Bolts and nuts - Snug tighten and then tighten an additional one half turn.

Set Screws - Snug tighten and tighten an additional full turn.

Position the swing frame.

Step 8: Place the swing frame into the footings. Square and level the swing frame assembly at specified footing depth. Top rail height shall be 96 in. (2438 mm) as measured from top of the protective surfacing material level to the bottom of the top rail. Fully tighten all bolts in accordance with tightening torque installation instructions. Block and brace for concrete.

Step 9: Fill the footings with concrete to within 2 in. (51 mm) of ground level as shown in the **Footing Detail**. Plumb and level the component. Block and brace for concrete. Allow concrete to harden for 72 hours before proceeding with **Step 10**.

Attach swing hangers to the top rail.

Step 10: Attach swing hangers to the top rail. See **Detail C**. Close the clamps around the top rail and attach as shown. Ensure hangers are properly spaced and positioned on top rail (See **Elevation View**). There is a ridge on the underside of the bottom band to keep the T nut from rotating. **When tightening the bolt ensure that the T nut does not protrude past the edge of the clamp.**

Note: Please read **CAUTION** before fully tightening the connections.

Important Note: Swing hangers should be positioned a minimum of 20" (508 mm) apart. Additionally, the horizontal distance between the vertical support and the swing shall be no less than 30 in. (760 mm) when measured at 60 in. (1524 mm) from the level of protective surfacing. Please refer to the USCPSC Handbook for Public Playground Safety for proper placement.

Step 11: Attach each clevis to a swing hanger. See **Detail D**. Position each clevis over the bottom hanger bushing and align holes. Insert a hex head bolt through the clevis eye, through the hanger bushing, through the other clevis eye and secure with a thin series lock nut.

Important Note: Tighten the thin series lock nut on shoulder bolt until the clevis binds on the swing hanger casting. Then loosen the thin series lock nut approximately 1/4 turn until the swing clevis moves freely. Insure the bolt threads are fully engaged into the nut's locking device.

Note: Swing clevises will need to be removed from swing hangers to install selected swing seat.

Final Details

Step 12: See Swing Seat Installation Instruction sheet for swing seat attachment. Swing seats are ordered separately.

Step 13: Tighten **all** fasteners. Fully tighten all fasteners according to tightening torque specifications.

Torque Specifications:

Bolts and nuts - Snug tighten and then tighten an additional one half turn.

Set Screws - Snug tighten and tighten an additional full turn.

Step 14: Install drive rivets. See **Detail E**. After the equipment assembly is complete, install a drive rivet in each clamp to permanently secure it to the support post. Using a 1/4" drill bit, drill through the clamp and support post. Insert the drive rivet into drilled hole until the head of the rivet is against the surface of the clamp. Using a hammer, drive the pin of the rivet until it is flush with the surface of the rivet head.

Note: This step should be executed after structure has been assembled and properly footed.

Step 15: For areas complying with ASTM standard F1487 or the CSA Z-614, apply the age appropriate label to the equipment at eye level.

XX0370 - 5 in. O.D.(127 mm) 2-UNIT ALUMINUM ARCH SWING ADD-A-BAY

PART NO.	DESCRIPTION	QTY.
AAU0155	HANGER - 5" SWING	4
ABC0704	CONNECTOR - SWING CLEVIS	4
APT0145	POST - 5" O.D. x 133-1/2" DUAL ALUM ARCH SUPPORT	1
APT0432	BEAM - 5" x 126" ARCH SWING TOP RAIL	1
BAD0085	THREAD LOCKING ADHESIVE	1
BAE0020	RIVET - 1/4" x 11/16" DRIVE	4
BAE0412	BOLT - 3/8"-16 x 2 1/2" HEX HEAD SHOULDER	4
BAE0610	NUT - 3/8"-16 THIN LOCK	4
BAE0620	NUT - 3/8"-16 LOCK w/NYLON CAP	2
BAE0630	SCREW - 3/8"-16 x 1/2" SOCKET SET SS	4
BAE0662	BOLT - 3/8"-16 x 1-1/4" TAMP RESIST w/TORX DRIVE	4
BAE06686	BOLT - 3/8"-16 x 5.50" BUTTON HEAD - SS	2
BAE0670	T-NUT - 3/8"-16 x 7/16" - SS	4
BAE0905	WRENCH - 3/16" SHORT HEX KEY	1
BAE0915	BIT - 3/8" TAMPER RESISTANT	1
BAE0922	TOOL - TT 45 L WRENCH	1
ALB0025	LABEL - ASTM AGE APPROPRIATE	1



PLAYWORLD SYSTEMS®
 The world needs play.™
 For Customer Service, Call
800-233-8404 or
570-522-9800 OUTSIDE U.S.
 1000 Buffalo Road • Lewisburg, PA 17837
www.playworldsystems.com



Installation Instructions

FINAL INSPECTION

- Playworld Systems® insists on the installation of protective surfacing within the use zone of each play structure in accordance with the applicable standard for your area, appropriate for the fall height of each structure.
- Playworld Systems® strongly recommends close supervision of children as they play. The owners of playground equipment and the parents or guardians of children are responsible for this proper supervision.
- As the owner of playground equipment, you are responsible for the maintenance of the equipment and surrounding play area. A comprehensive maintenance and inspection schedule must be developed and all equipment inspected frequently. Refer to the inspection and maintenance schedule in the back of this booklet.
- Perform a thorough final check on the installed equipment to insure all equipment is installed as specified by manufacturer's installation instructions.
 - Review all Installation Instructions for specified dimensions. Make sure dimensions called for in instructions agree with actual installation.
 - Double check height dimensions. Height measurements are taken from the top of the protective surfacing material.
 - Insure all fasteners are tightened according to tightening torque specifications listed on your installation instructions.
 - Clean dried concrete off of components and any other affected surface.
 - Touch-up any scratches or installation damage to powder coated finish with color-matched spray paint.
 - Allow adequate time for proper curing, both for concrete and urethane cement if rubber safety surfacing tiles have been installed.
 - Insure that protective surfacing is properly installed according to recommendations. Footings must not be exposed. Refer to the florescent orange sheet included in the front of the installation instruction booklet titled "Owners Manual".
 - Insure that hard surface warning/Playworld Systems® identification labels (shown below) are properly affixed to the play equipment. Labels are to be plainly visible according to current playground equipment guidelines. For areas complying with ASTM F-1487 or CSA Z-614 an age appropriate label must be applied in a visible location.

- Dispose of all packaging material properly. These materials which include large plastic bags and sheets can be a suffocation hazard. Dispose of these materials out of reach or contact of small children.



This page is
intentionally left blank.



Swing Hangers

- Inspect swing hangers to insure they are properly secured to the support posts.
- Use the supplied torx-style tamper-resistant bit to insure bolt connection is tight.
- Use the supplied 3/16" hex key wrench to insure the set screw connection is tight.
- Inspect drive rivets to insure they are intact and secure.
- Visually inspect swing hangers for cracks or breakage. If any damage is detected, barricade equipment to prevent use until repair is completed. Contact your sales representative immediately for a replacement part.

Fasteners

- Inspect for loose fasteners.
Tightening torque specifications are:
Bolts and Nuts: Snug tighten and tighten an additional one-half turn.
Set Screws: Snug tighten and tighten an additional full turn.
- If during the maintenance process a bolt needs to be removed from a part or parts, it will be necessary to apply a drop of liquid thread lock / loctite to the bolt before reinstallation.
- Inspect for missing, worn or broken fasteners. If any missing, worn or broken fasteners are found, refer to the installation instructions for proper replacement fastener. If any damage is detected, barricade equipment to prevent use until repair is completed. Contact your sales representative immediately for a replacement part.

Welds

- Inspect all welded joints. If any broken welds are detected, barricade equipment to prevent use until repair is completed. Contact your sales representative immediately for a replacement part.

Finish

- Inspect metal parts for finish damage.
To repair painted surfaces, sand damaged area with sandpaper and wipe clean. Mask area and paint with primer and allow to dry. Paint primed area with color-matching paint and allow to dry. Recoat area with color-matching paint if required. Drying time is approximately 8 hours between coats.

Footings

- Inspect component to be solid in footing and secure. If any damage is detected, barricade equipment to prevent use until repair is completed.

Surfacing

- Refer to the specific surfacing maintenance detail sheet for additional information.

Replacement Parts

- Refer to your installation instructions to obtain replacement part number.
- Contact your sales representative or call Playworld Systems' Customer Service for a replacement part.

Equipment Maintenance Playworld Systems® Model XX0370 5 in. (127 mm) O.D. 2-Unit Aluminum Arch Swing Add-A-Bay



Warning!
Exceeding 25 ft lbs (33.9 Nm) of torque on the swing hanger bolts may cause damage to the swing band.

PLAYWORLD SYSTEMS®
The world needs play.™
For Customer Service, Call
800-233-8404 or
570-522-9800 OUTSIDE U.S.
1000 Buffalo Road • Lewisburg, PA 17837
www.playworldsystems.com

Inspection Form

- Be sure that you are using a copy of this Inspection Form and not your original.
- Use the Inspection Codes listed below and record condition of equipment at time of examination on the Inspection Checklist.
- Document any item from the Inspection Checklist that will require maintenance along with any corrective action on the Maintenance Schedule.
- Be sure to include appropriate dates and signatures on each section to properly document maintenance procedure.

Preventive Maintenance ... for Safety's Sake!

INSPECTION CHECKLIST

	Frequency	Inspection Code	Date	Date Repairs Completed
Inspect surfacing to insure proper depth and distribution.	High			
Inspect swing hangers for tightness and damage.	High			
Inspect metal parts for structural and finish damage.	Medium			
Inspect for loose, missing, worn, or broken fasteners.	High			
Inspect footing to insure support is secure and footing is not damaged.	Low			

Inspection Codes

P = Pass F = Fail
NA = Not Applicable

Inspector: Name (Please Print) _____ Signature: _____ Date: ___/___/___

MAINTENANCE SCHEDULE

Item in Question	Description of Problem	Corrective Action	Date

Repairer: Name (Please Print) _____ Signature: _____ Date: ___/___/___



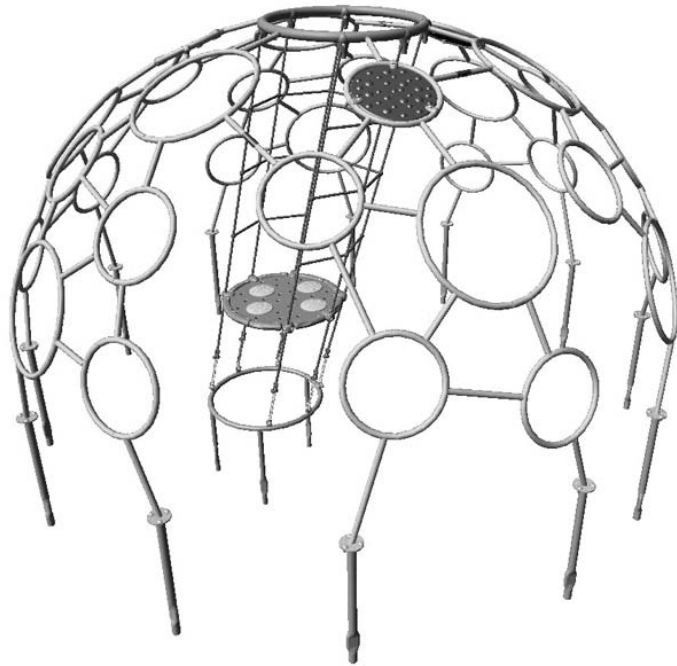

Assembly View (*representative structure*)

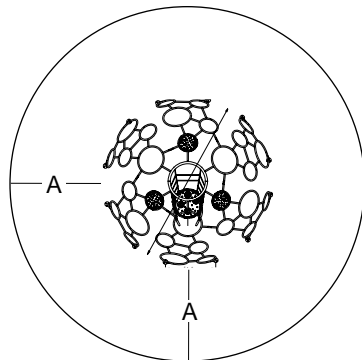

Equipment Use Zone
A - (ASTM): 72 in. (1830 mm)
(CSA): 1800 mm
(EN): 1925 mm

Installation Instructions

Playworld Systems[®]





Models XX0366 and XX0366S

Unity Dome

In-Ground and Surface Mount

Installation Preparation

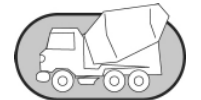
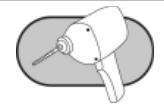
Recommended Crew: Four (4) adults
 Installation Time (In-ground): 20 man-hours
 Installation Time (Surface Mount): 10 man-hours
 Concrete Required: 1.80 cubic yard (1,40 cubic meters)
 Use Zone: Refer to the information below
 User Group Age (years): ASTM/CSA: 5-12, EN: 6-14

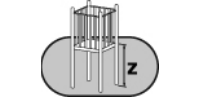
ICON KEY			
	Fully Tighten Hardware		Add 1 Drop of Thread Locking Adhesive
	Do Not Fully Tighten Hardware		Pour Concrete
	Drill		Dig Footing Holes
	Hammer		Critical Fall Height

Installation Instructions

Top View

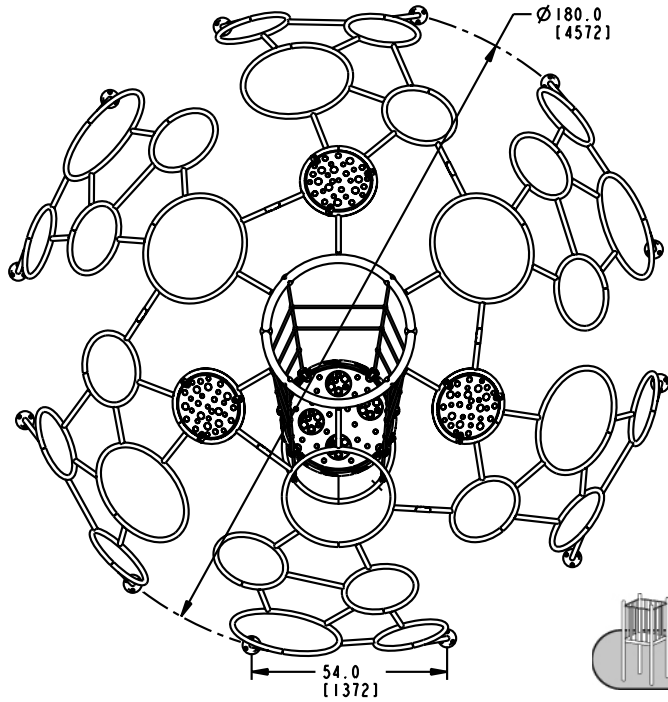

KEY

Position #	Unit of Measurement
Top #	Inches
Bottom #	[Millimeters]

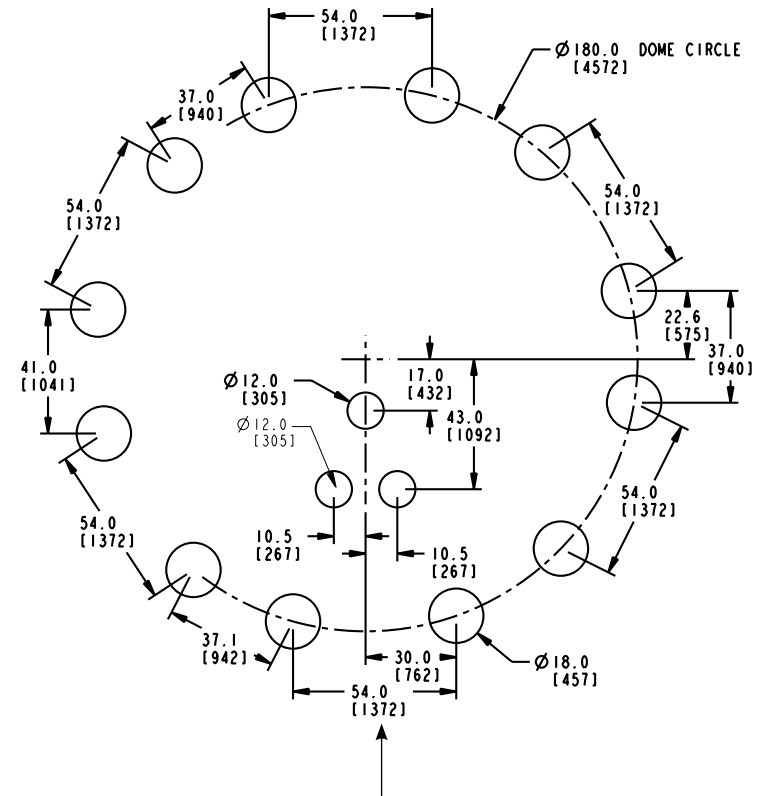

Important Note: When assembling and placing the climbers in the footings, make sure to position one of the climbers, (ACL0422) with the large ring at the top, here in front of the interior footings for the platform / net assembly.

Footing Diagram
In-Ground

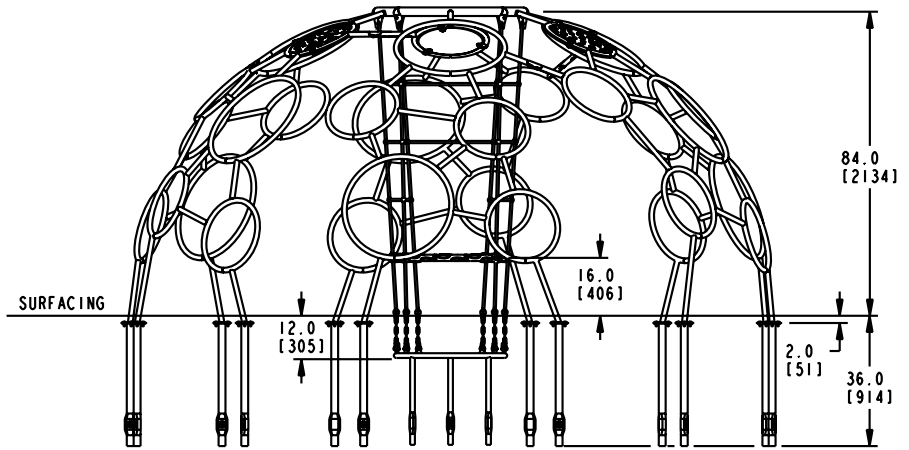

Elevation Views
XX0366



Installation Instructions

KEY	
Position	Unit of Measurement
Top #	Inches
Bottom #	[Millimeters]

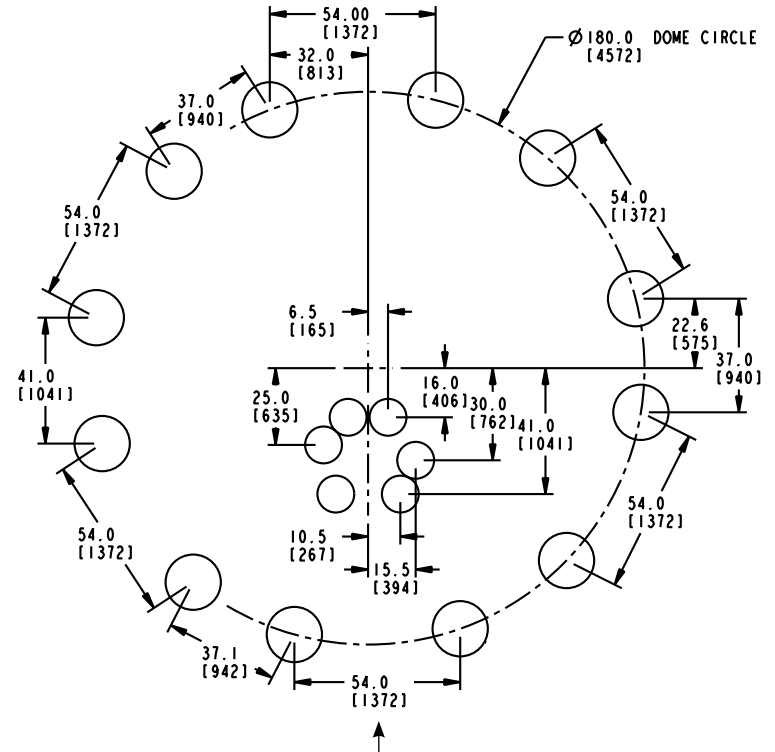
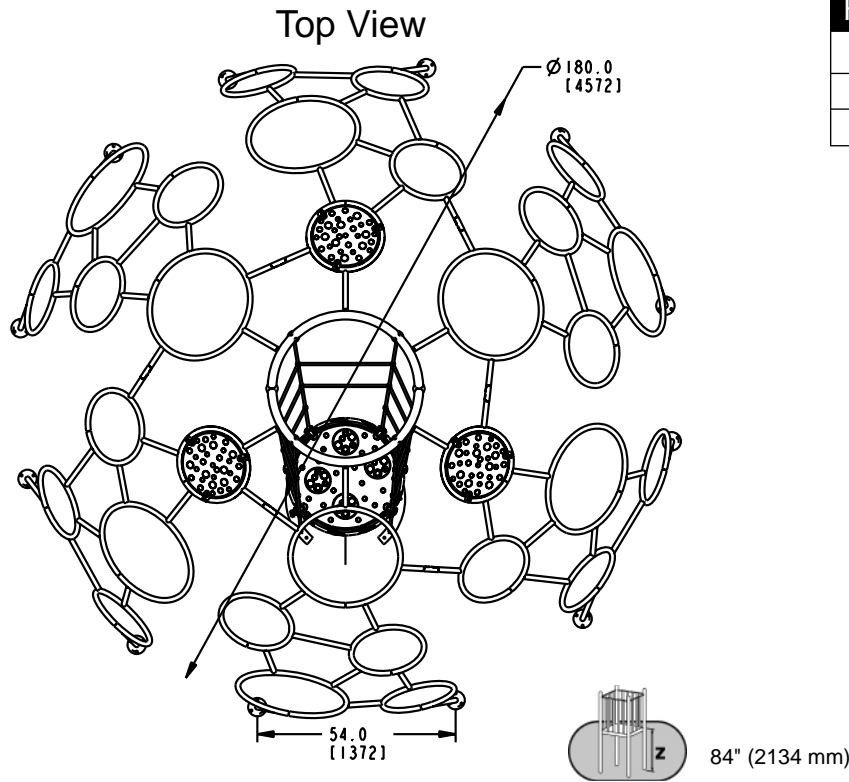

Important Note: When assembling and placing the climbers on the footings, make sure to position one of the "A" loop climbers (ACL0422) with the large ring at the top here in front of the interior footings for the platform / net assembly.

Footing Diagram
Surface Mount

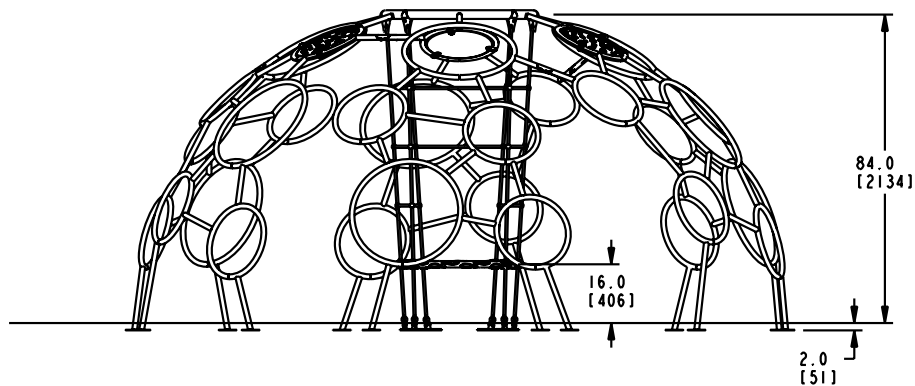

Elevation Views
XX0366S



Installation Instructions

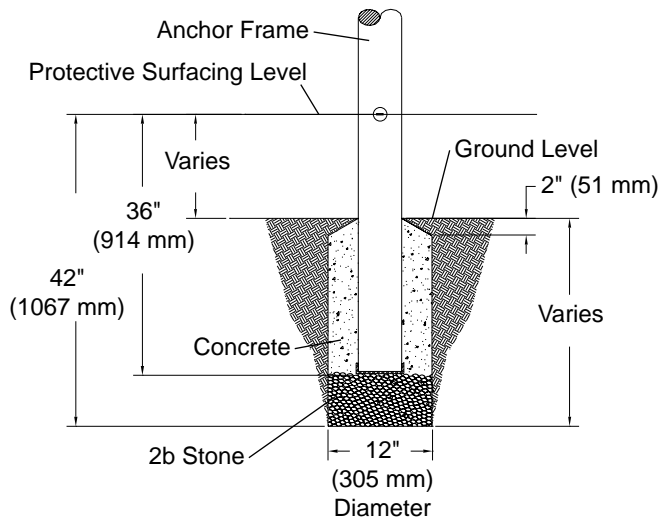

Anchor Frame Footing Detail (ASTM/CSA)

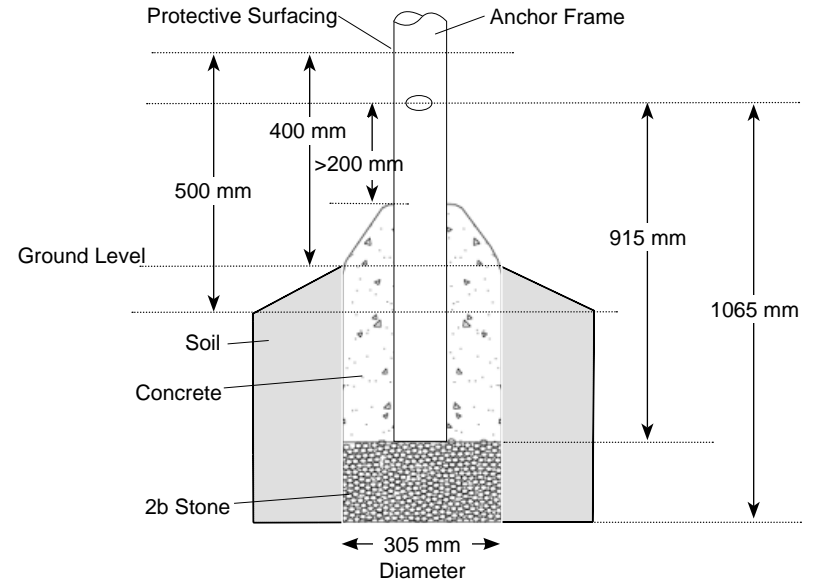

Anchor Frame Footing Detail (EN)

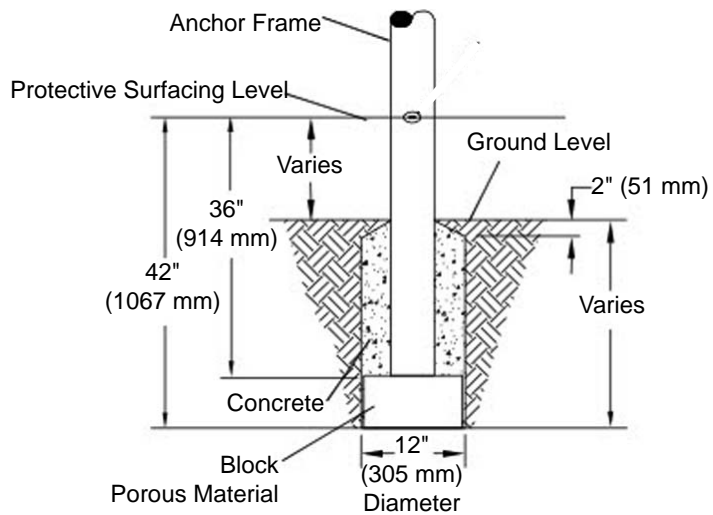

Anchor Frame Footing Detail (ASTM/CSA)
Block Option

Installation Instructions

FOOTING NOTES

- Anchor frame footing depth equals 42 in. (1067 mm) less the depth of the protective surfacing material. The post is designed to have 24" (610 mm) in concrete.
Example: If 12 in. (305 mm) of wood mulch is used for surfacing, the footing depth would be 30 in. (762 mm).
- Some support posts and component support legs may have either a factory-applied sticker with line, or factory-applied mark designating protective surfacing level on a clear and level installation site.
- If play structure is installed on uneven terrain, maintain support post mark at protective surfacing level at lowest grade. Adjust other footings accordingly. Support posts and all attaching decks and play components must be plumb and level.
- Do not encase bottom of support post in concrete. Place post directly on packed stone or porous block.
- The footings shown on Playworld Systems' documentation are recommendations based on historical performance in average soil conditions. Footing dimensions may be modified by the owner based on actual soil conditions.
For example:
 - If local soil is loose or unstable, a larger footing may be required.
 - If local soil is considered stable, such as bedrock, clay or hard packed earth, a smaller footing may be used. Before changing footing dimensions, we strongly recommend that the footings be reviewed and approved by a registered engineer.
- Base of footing must be below frost line.
- Assemble the entire structure before pouring concrete unless specifically instructed to do so in the individual component installation instructions.

Installation Instructions

Follow the details in alphabetical order. For clarification, each detail references the step description. The step descriptions start on page 17.

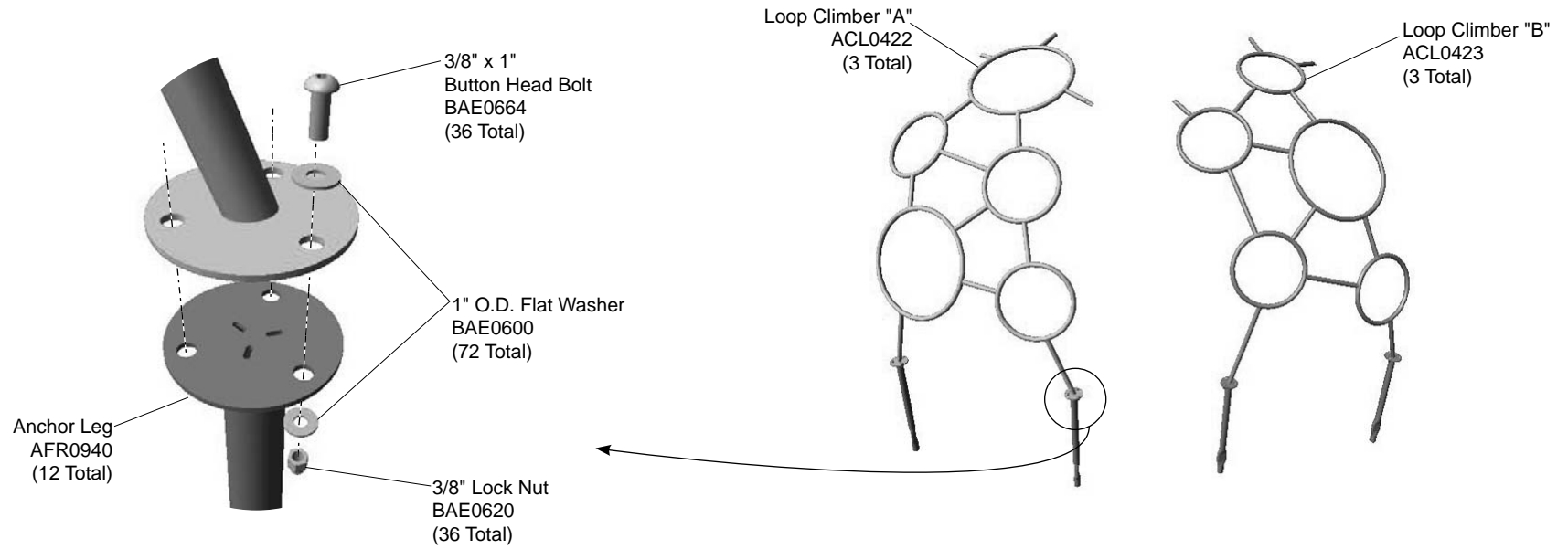

Detail A (In-Ground Model Only)

Step 4

Attach the anchor legs to the loop climbers.

Installation Instructions

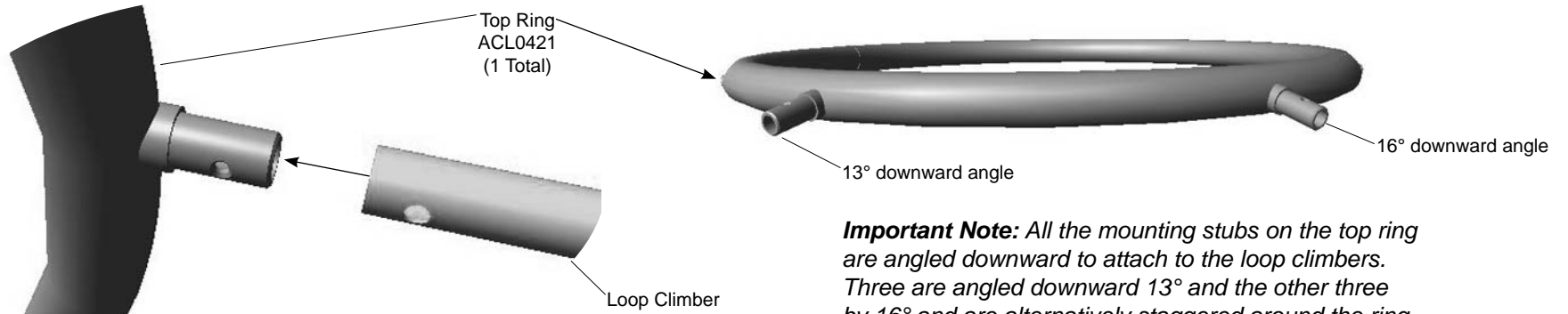

Important Note: All the mounting stubs on the top ring are angled downward to attach to the loop climbers. Three are angled downward 13° and the other three by 16° and are alternatively staggered around the ring. Attach loop climbers "A" to the 13° angled stub and loop climbers "B" to the 16° angled stub.

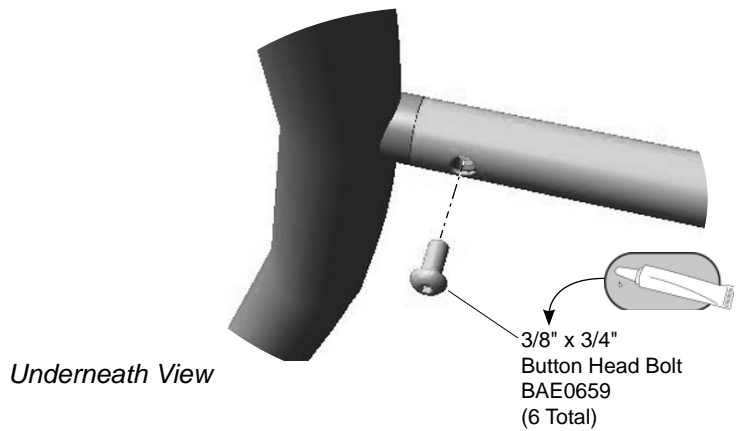

Detail B
Step 5



Attach the loop climbers to the top ring.

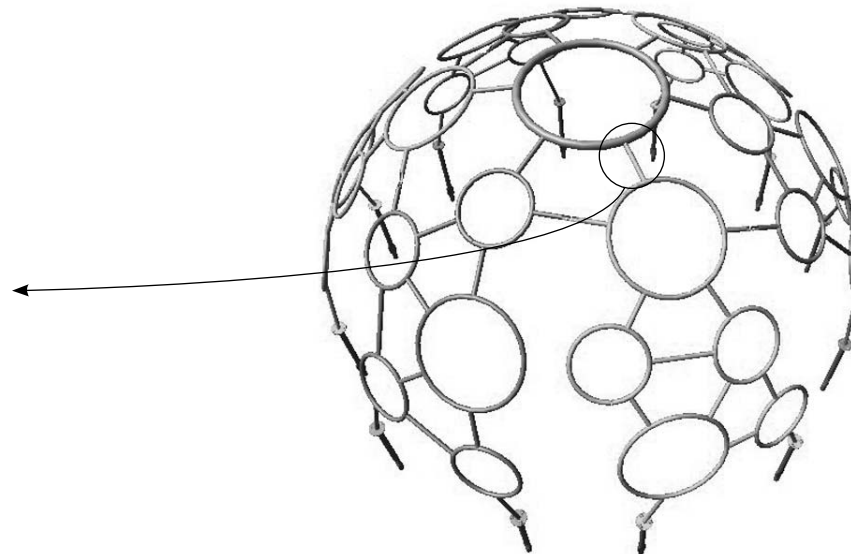

Place the climbers in, or on, their footings as you assemble the dome. See the **Important Note** under the **Footing Diagram**.

Installation Instructions

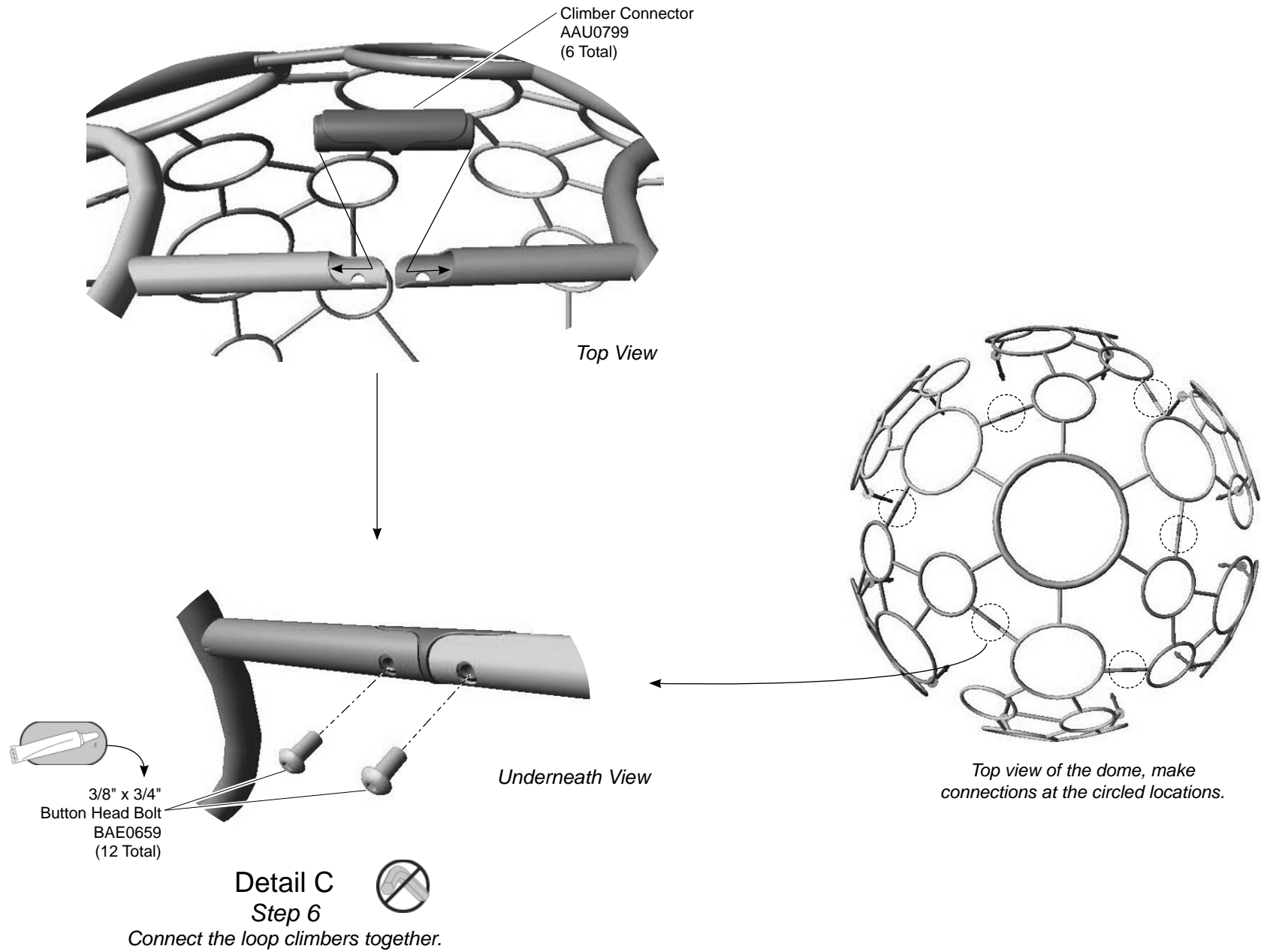

Installation Instructions

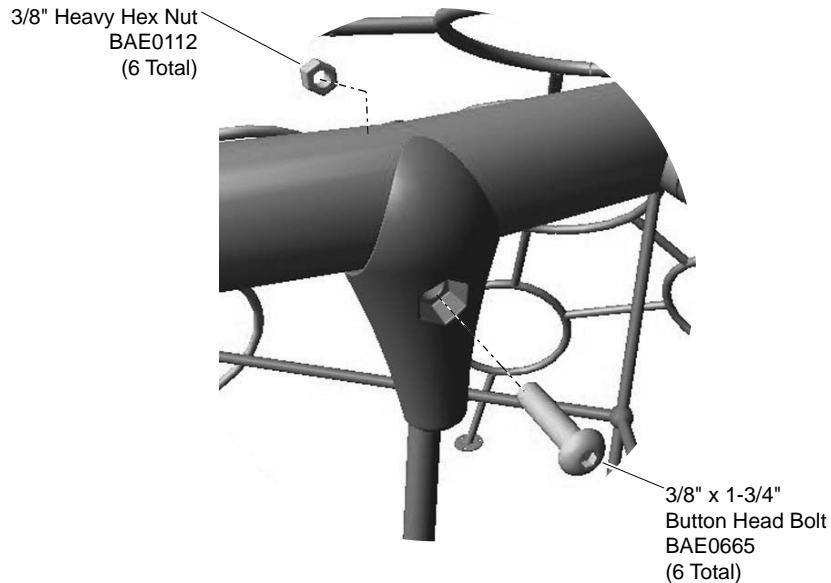
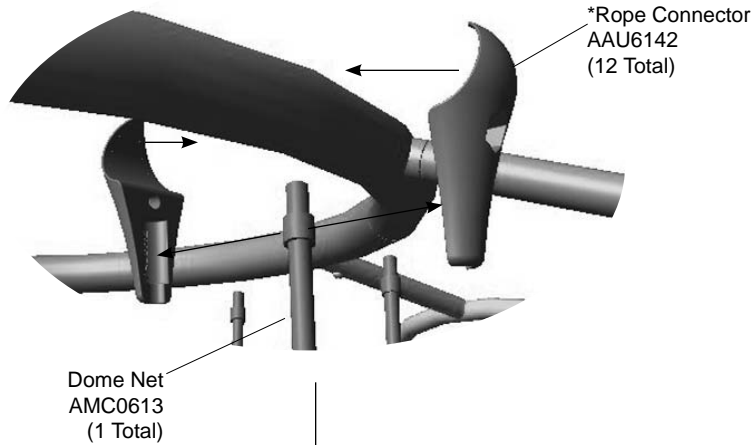

Attach the dome net to the top ring.

***Important Note:** Reference the **Rope Connector Placement Top View** below for placement of the net and the rope connectors. The open side of the net should be facing the footings for the net.

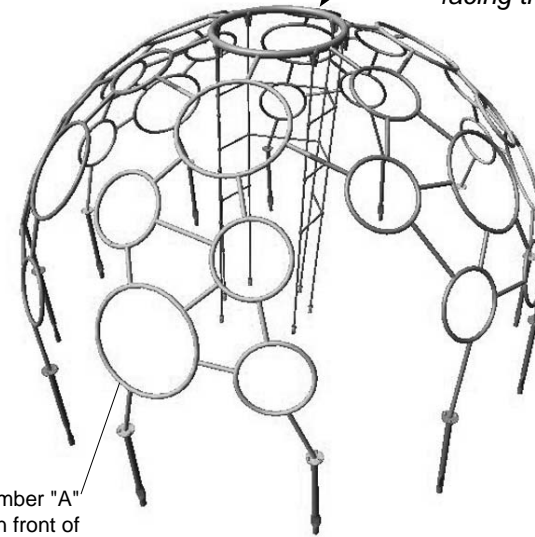

KEY	
Position	Unit of Measurement
Top #	Inches
Bottom #	[Millimeters]

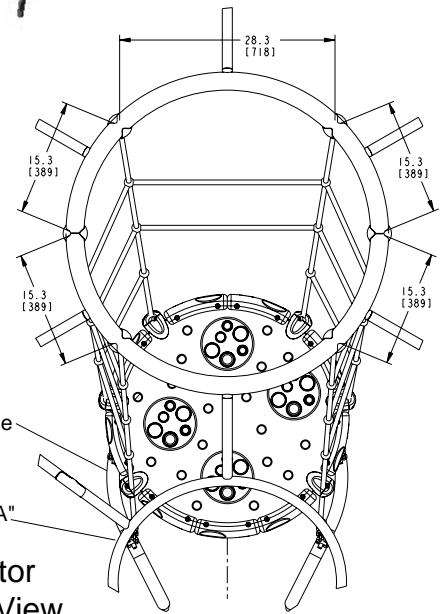

Installation Instructions

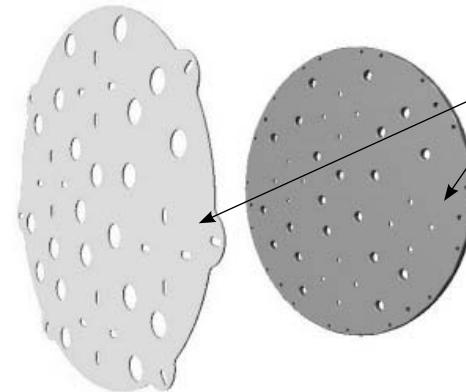
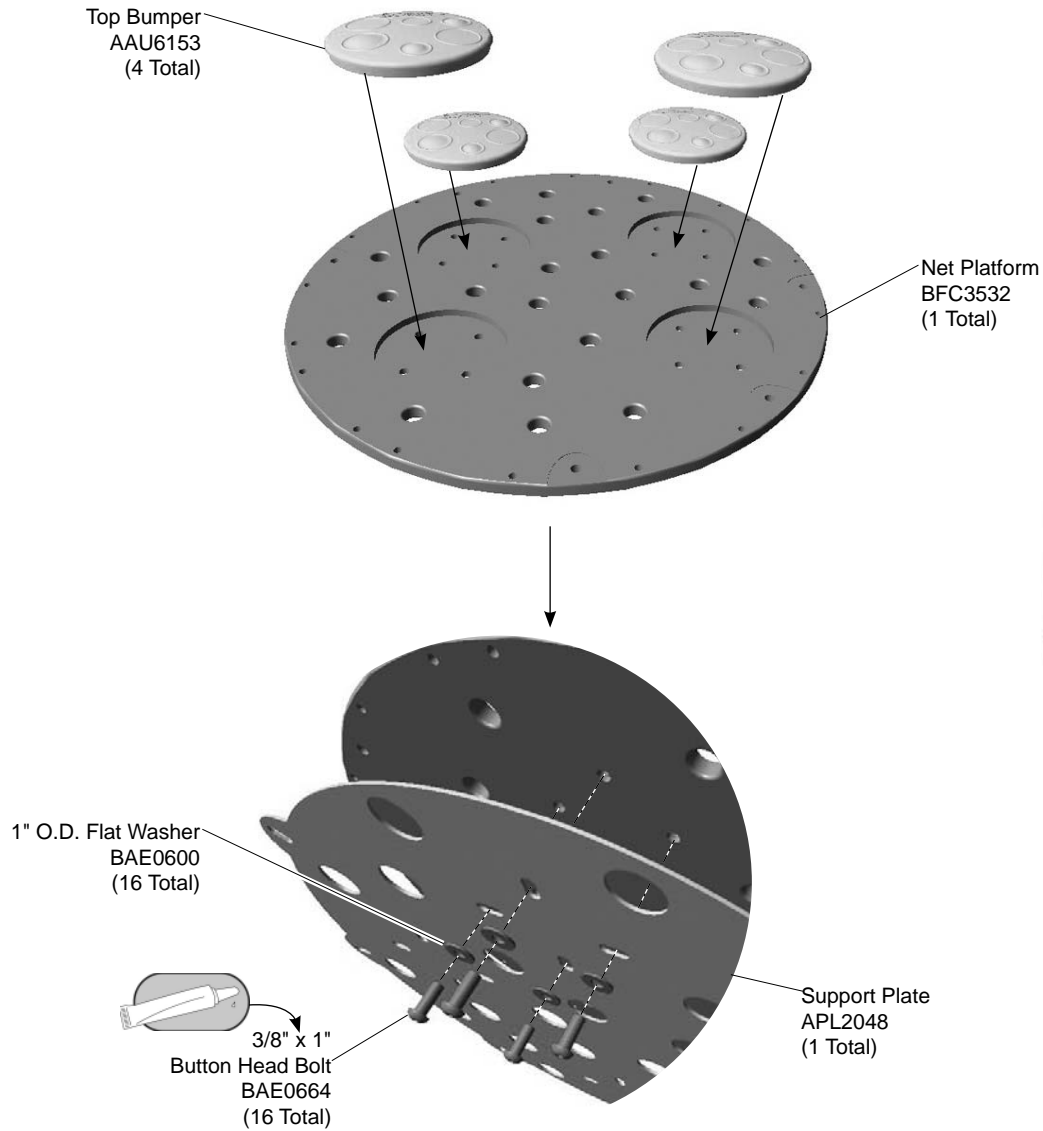

Plate to Platform
Alignment Reference

Detail E

Step 8

Attach the top bumpers and support plate to the net platform.

Installation Instructions

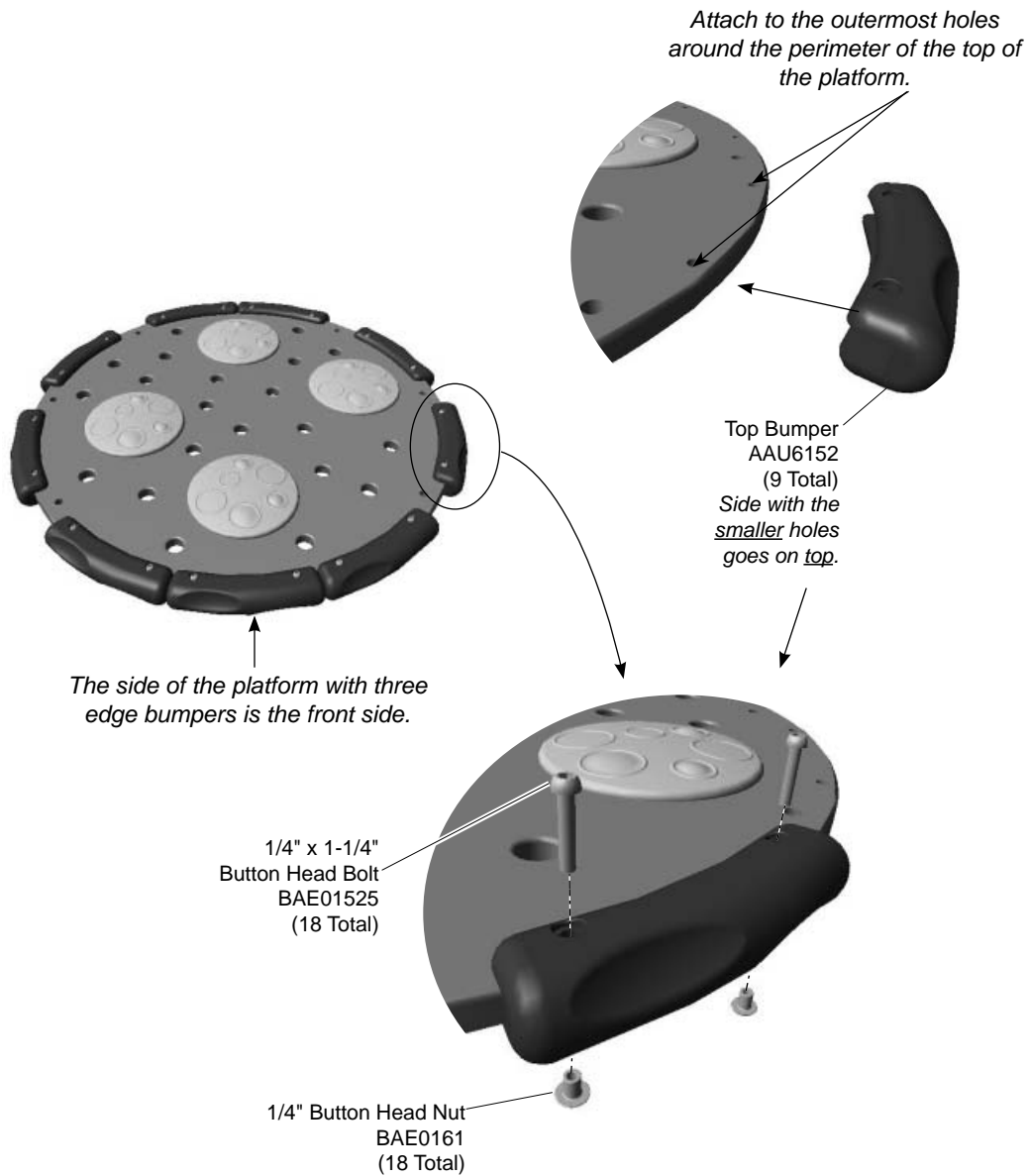



Detail F
Step 9

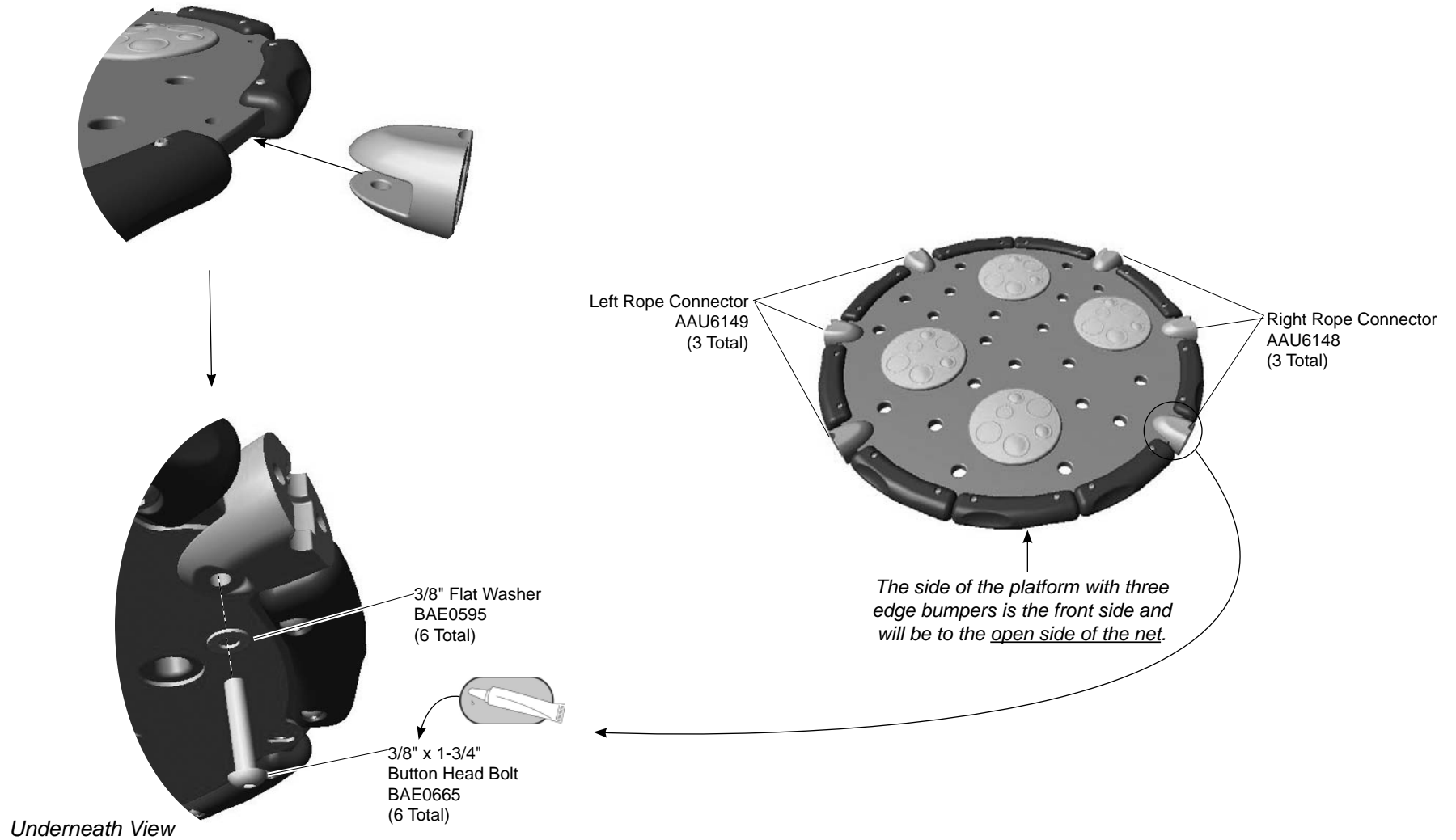

Attach the edge bumpers to the platform.

Installation Instructions



Detail G 
Step 10

Attach the left and right rope connectors to the platform.

Installation Instructions

Ferrule on the rope seats inside the rope connector.

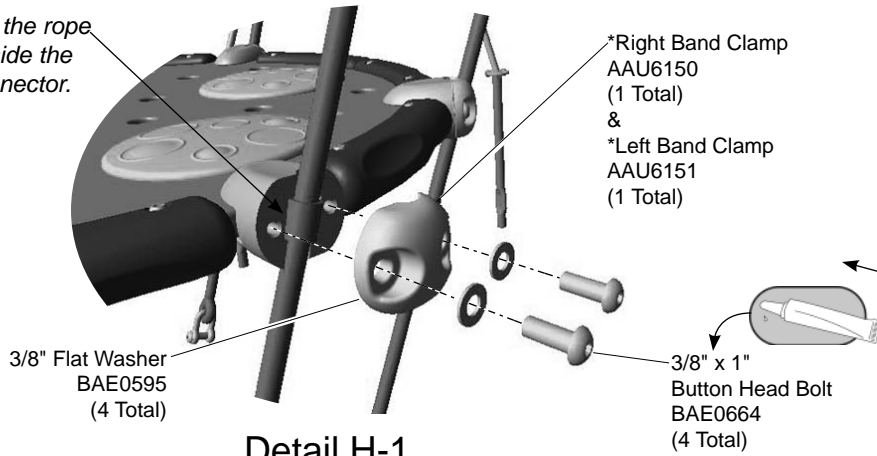

*Right Band Clamp
AAU6150
(1 Total)
&
*Left Band Clamp
AAU6151
(1 Total)

3/8" Flat Washer
BAE0595
(4 Total)

3/8" x 1"
Button Head Bolt
BAE0664
(4 Total)

Detail H-1

First attach the net platform to the two ropes on the dome net that have ferrules.

***Note:** Right band clamps attach only to the right rope connectors and left band clamps attach only to the left rope connectors.

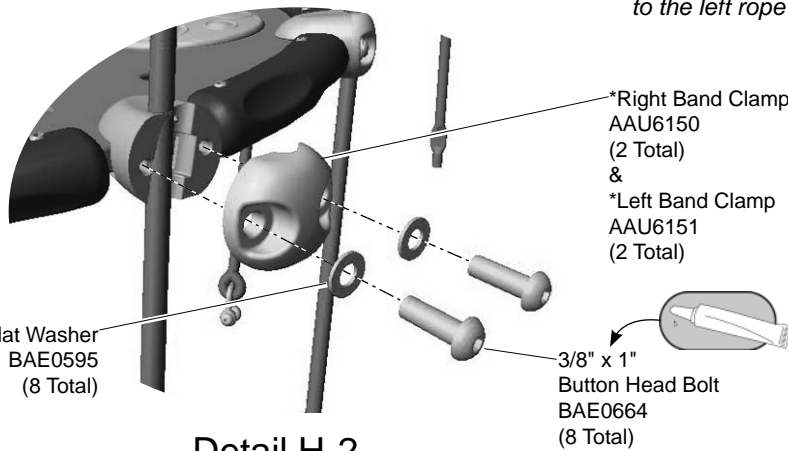
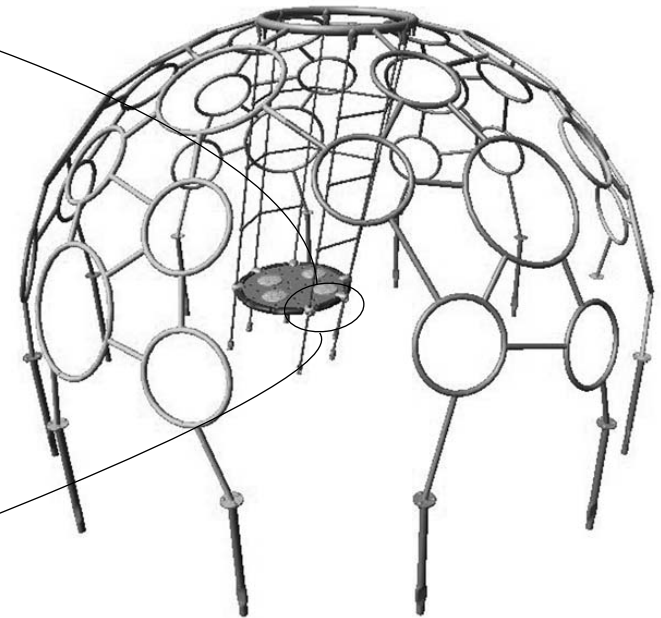

*Right Band Clamp
AAU6150
(2 Total)
&
*Left Band Clamp
AAU6151
(2 Total)

3/8" Flat Washer
BAE0595
(8 Total)

3/8" x 1"
Button Head Bolt
BAE0664
(8 Total)

Detail H-2

Straighten the net platform and attach to the remaining ropes on the net.

Details H-1 and H-2

Step 11

Attach the net platform to the dome net.



Installation Instructions

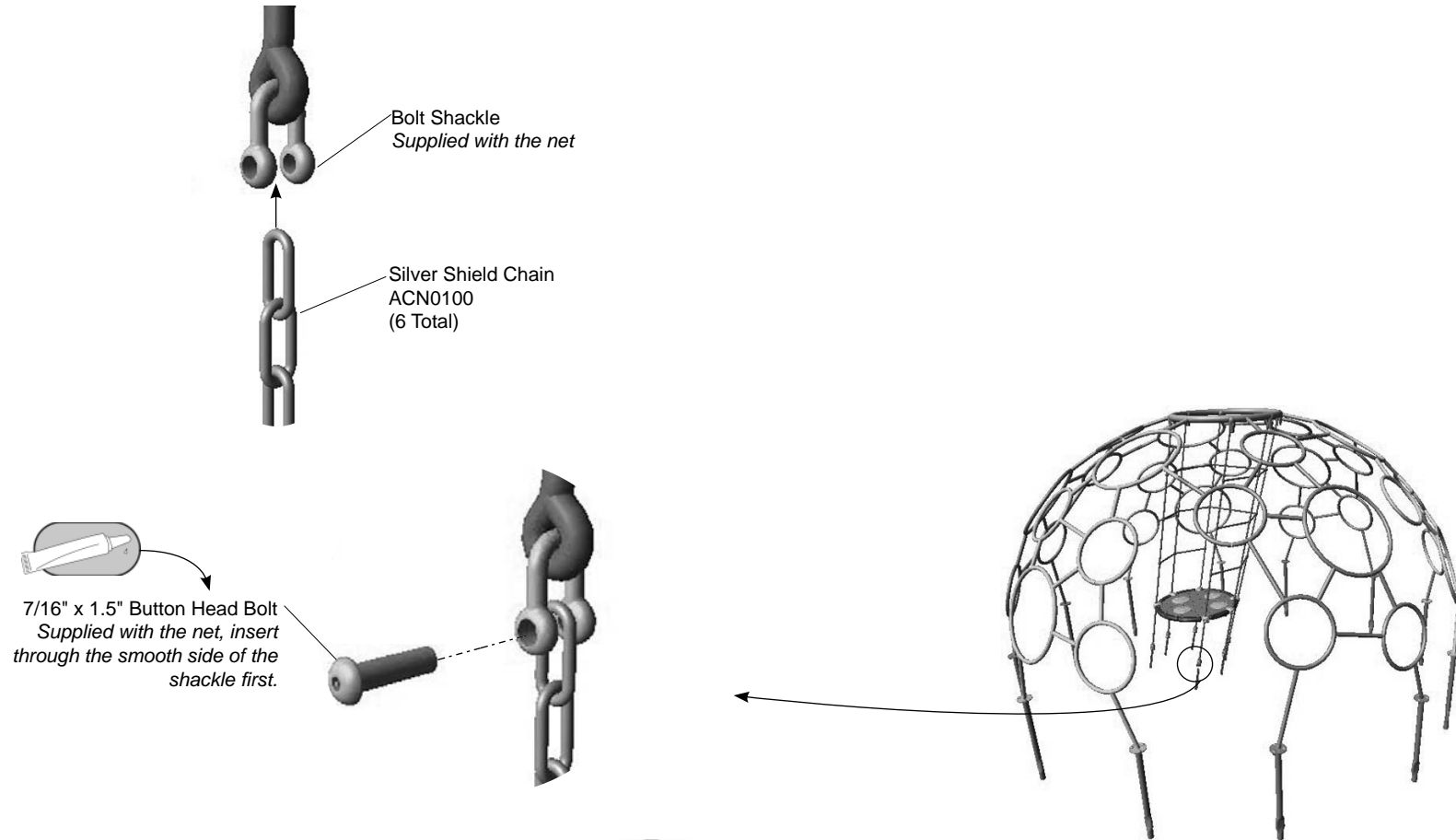

Detail I 
Step 11
(In-Ground Model Only)
Attach a chain to the end of each
net rope.

Installation Instructions

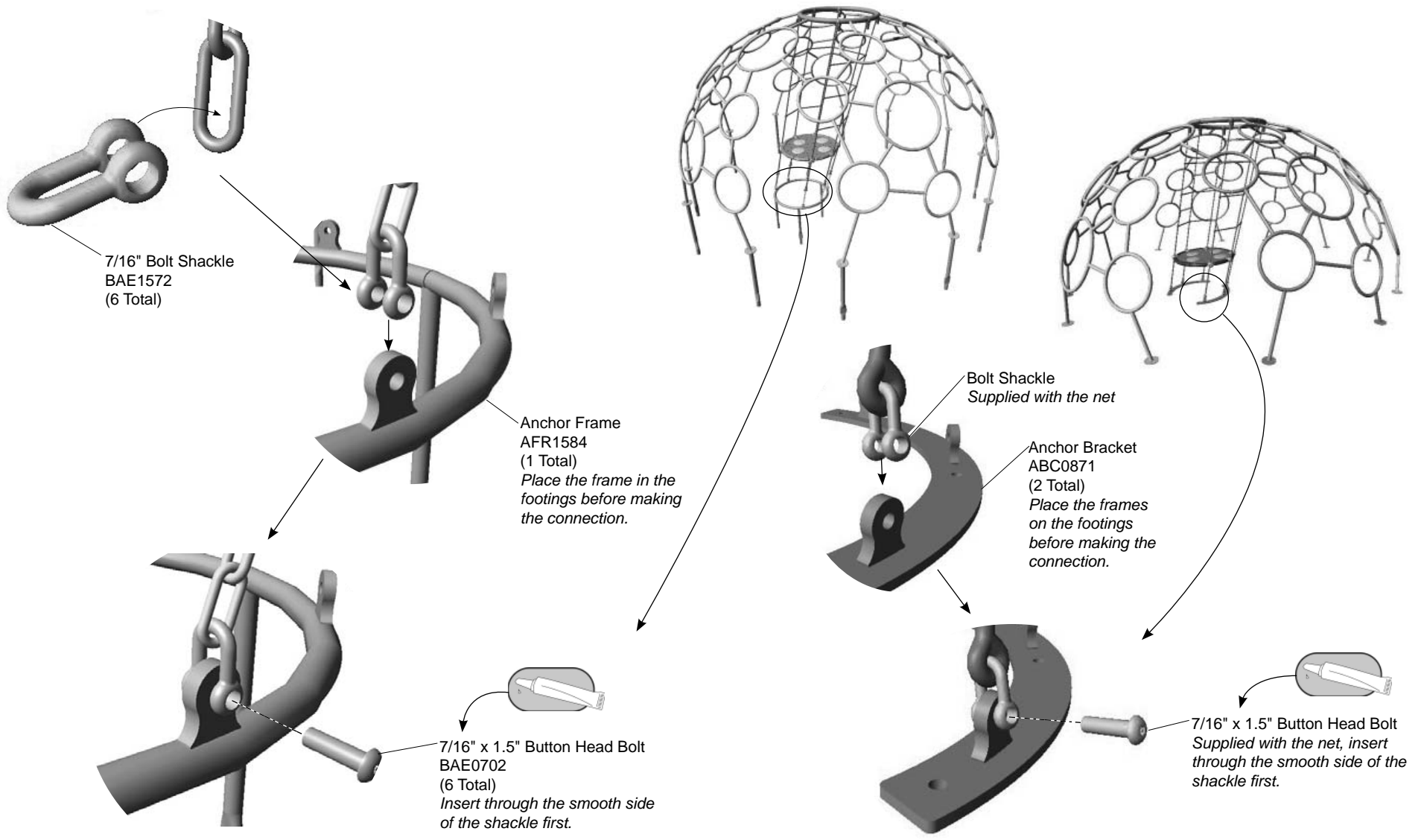

Detail J
Step 13

(In-Ground Model)

Attach the chains to the anchor frames.

Detail K
Step 14

(Surface Mount Model)

Attach the ends of the net to the anchor brackets.

Installation Instructions

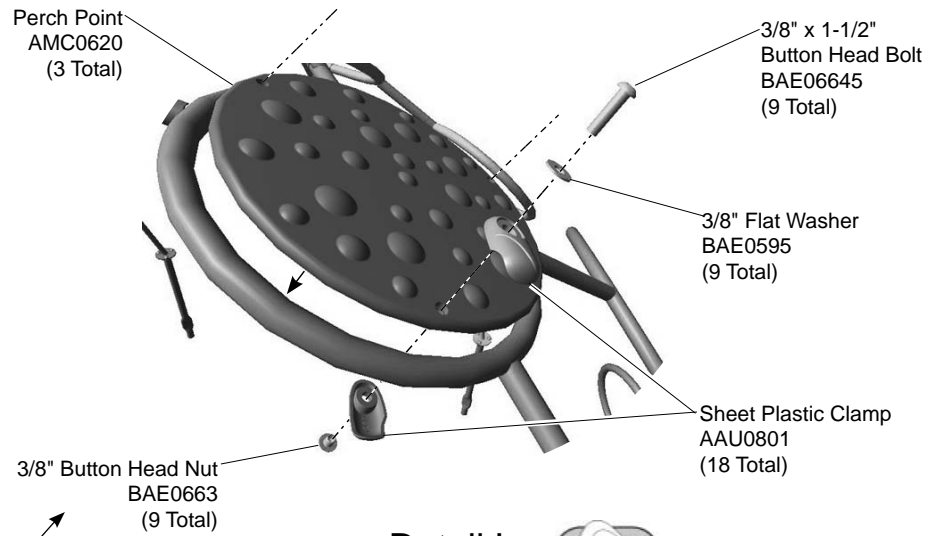

Detail L Step 15

Attach a perch to the upper ring on each loop climber "B".

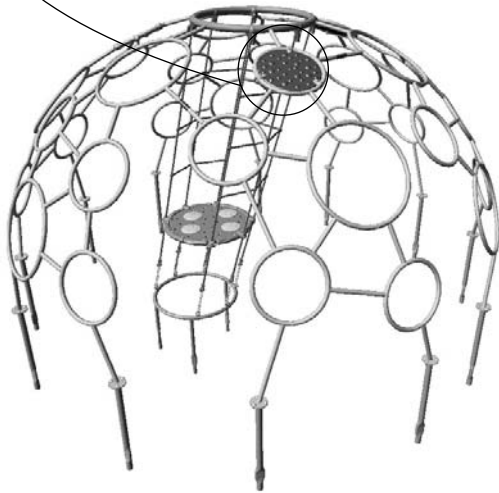

Installation Instructions

Notes Before You Begin: Do not over tighten bolts during assembly, only snug tighten them until assembly is complete.

Carefully read and understand these installation instructions before you begin.

Step 1: Before attempting to assemble your equipment, please review all installation information carefully. Should you experience any difficulty during the installation process, please call us at the phone number shown on the last page of these instructions.

Step 2: Separate and identify all components and hardware.

Step 3: Excavate, or prepare, the footings. For the *in-ground model*, use the **Support Post Footing Detail**, shown in the *Annex* of this document, for the 18 in. diameter holes (climber anchor legs) and the **Anchor Frame Footing Detail**, shown on **pages 4 & 5** of this document, for the 12 in. diameter holes (dome net anchor frame). See the **Footing Diagram** for the location of those holes. For the *surface mount model*, reference the **Surface Mount Footing Detail** in the *Annex* of this document and the appropriate **Footing Diagram**.

Step 4: (In-Ground Model Only) Attach the anchor legs to the loop climbers. See **Detail A**. Position the anchor legs against the bottom of the climbers and attach as shown. Fully tighten the connections according to tightening torque specifications.

Torque Specifications:

Bolts and nuts - Snug tighten and then tighten an additional one half turn.

Step 5: Attach the loop climbers to the top ring. See **Detail B**. Place the climbers in, or on, their footings as you assemble the dome. See the **Important Note** under the **Footing Diagram** for placement of the "A" and "B" climbers. Apply a drop of thread locking adhesive to the bolt threads and attach each climber to the correctly angled stub on the top ring as shown.

Step 6: Connect the loop climbers together. See **Detail C**. Insert the connectors into the climber side rails, apply a drop of thread locking adhesive to the bolt threads, and attach as shown.

Step 7: Attach the dome net to the top ring. See **Detail D**. Position the end of each dome net rope between a pair of rope connectors around the top ring and attach as shown.

Important Note: Reference the **Rope Connector Placement Top View** for placement of the net and the rope connectors. *The open side of the net should be facing the footings for the net.*

Step 8: Attach the top bumpers and support plate to the net platform. See **Detail E**. Position the support plate against the bottom of the net platform and align the holes (See **Plate To Platform Alignment Reference**). Insert the bumper into the top of the platform and align the holes. Apply a drop of thread locking adhesive to the bolt threads and attach as shown.

Step 9: Attach the edge bumpers to the platform. See **Detail F**. Insert each bumper onto the edge around the perimeter of the platform and align with the two small outer most hole, and attach as shown. The side of the platform with three edge bumpers is the **front** side.

Step 10: Attach the left and right rope connectors to the platform. See **Detail G**. Using the front side of the platform as a point of reference, attach the right rope connectors to the right side of the platform and the left rope connectors to the opposite side.

Step 11: Attach the net platform to the dome net. See **Details H-1 and H-2**. Position the net platform between the dome net with the side with three bumpers to the open side of the net. Straighten and attach the net platform to the two ropes on the dome net that have ferrules. Ensure the ferrules are seated in the connectors and clamps before making the connection. As with the rope connectors the right and left band clamps attach to the respective side of the platform. Apply a drop of thread locking adhesive to the bolt threads before making the connections.

Step 12: (In-Ground Model Only) Attach a chain to the end of each net rope. See **Detail I**. Apply a drop of thread locking adhesive to the bolt threads and attach each chain to the end of dome net. Fully tighten the connections according to tightening torque specifications.

Installation Instructions

Step 13: (*In-Ground Model*) Attach the chains to the anchor frame. See **Detail J**. Ensure the anchor frame is positioned correctly in the footings, apply a drop of thread locking adhesive to the bolt threads, and attach as shown to the chains. Fully tighten the connections according to tightening torque specifications.

Step 14: (*Surface Mount Model*) Attach the ends of the net to the anchor brackets. See **Detail K**. Ensure the anchor brackets are positioned correctly on the footings, apply a drop of thread locking adhesive to the bolt threads, and attach as shown to the chains. Fully tighten the connections according to tightening torque specifications.

Step 15: Attach a perch to the upper ring on each loop climber "B". See **Detail L**. Position a perch on top of each upper ring on loop climber "B" and attach as shown. Fully tighten the connections according to tightening torque specifications.

Final Details.

Step 16: Plumb and level the component. **Pull on the net to tighten the ropes and level the platform before anchoring.** Tighten **all** fasteners. Fully tighten all fasteners according to tightening torque specifications.

Torque Specifications:

Bolts and nuts - Snug tighten and then tighten an additional one half turn.

In-Ground: Block and brace for concrete. Pour concrete after all equipment has been assembled. Allow 72 hours for concrete to completely cure.

Surface Mount: Bolt down all surface mount supports in accordance with specifications provided by your registered structural engineer.

Important Note: Surface mount hardware is not supplied. Customer is responsible for concrete base and for providing surface mount hardware as specified by a registered structural engineer for each specific project application.

Step 17: For areas complying with ASTM standard F1487 or the CSA Z-614, apply the age appropriate label to the component at eye level.

Bill of Materials

XX0366 - UNITY DOME

PART NO.	DESCRIPTION	QTY.
AAU0799	CNNCTR - 1.375" O.D. x 4.75" THREADED HOLES	6
AAU0801	CLAMP - 1.315" DIA TO SHEET PLASTIC	18
AAU6142	CASTING - 2.38" O.D. TUBING ROPE CNNCTR	12
AAU6148	CASTING - SHEET / ROPE CNNCTR - RIGHT	3
AAU6149	CASTING - SHEET / ROPE CNNCTR - LEFT	3
AAU6150	CASTING - SHEET / ROPE BAND - RIGHT	3
AAU6151	CASTING - SHEET / ROPE BAND - LEFT	3
AAU6152	BUMPER - PLATFORM EDGE	9
AAU6153	BUMPER - 7.00" DIA INSERT	4
ACL0421	CLIMBER - 40.00" DIA TOP RING	1
ACL0422	CLIMBER - UNITY DOME LOOP - A	3
ACL0423	CLIMBER - UNITY DOME LOOP - B	3
ACN0100	CHAIN - 5/0 SILVER SHIELD CHAIN - 5 LINKS	6
AFR0940	FRAME - 1.90" x 34.00" ANCHOR	12
AFR1584	FRAME - 30.00" DIA NET ANCHOR	1
AMC0613	UNITY DOME NET	1
AMC0620	PERCH POINT - 18.50" DIA x 1.25"	3
APL2048	PLATE - 11 GA x 27.50" DIA SUPPORT	1
BAD0085	THREAD LOCKING ADHESIVE	1
BAE0112	NUT - 3/8"-16 HEAVY HEX	6
BAE01525	BOLT - 1/4"-20 x 1-1/4" BUTTON HEAD - SS	18
BAE0161	NUT - 1/4"-20 x 7/16" BUTTON HEAD	18
BAE0595	WASHER - 3/8" SAE FLAT	27
BAE0600	WASHER - 1" O.D. FLAT	88
BAE0620	NUT - 3/8"-16 LOCK w/NYLON CAP	36
BAE0659	BOLT - 3/8"-16 x 3/4" BUTTON HEAD - SS	18
BAE0663	NUT - 3/8"-16 x 7/16" BUTTON HEAD	9
BAE0664	BOLT - 3/8"-16 x 1" BUTTON HEAD - SS	64
BAE06645	BOLT - 3/8"-16 x 1-1/2" BUTTON HEAD - SS	9
BAE0665	BOLT - 3/8"-16 x 1-3/4" BUTTON HEAD - SS	12
BAE0702	BOLT - 7/16-14 x 1.50" - BUTTON HEAD	6
BAE0900	WRENCH - 5/32" SHORT HEX KEY	1
BAE0902	TOOL - 7/32" SHORT HEX KEY WRENCH	1
BAE0922	TOOL - TT 45 L WRENCH	2
BAE1572	7/16" BOLT SHACKLE	6
BFC3532	SHEET - .75" x 30.00" DIA PLATFORM	1
ALB0025	LABEL - AGE APPROPRIATE SHEET	1

XX0366S - UNITY DOME SURFACE MOUNT

PART NO.	DESCRIPTION	QTY.
AAU0799	CNNCTR - 1.375" O.D. x 4.75" THREADED HOLES	6
AAU0801	CLAMP - 1.315" DIA TO SHEET PLASTIC	18
AAU6142	CASTING - 2.38" O.D. TUBING ROPE CNNCTR	12
AAU6148	CASTING - SHEET / ROPE CNNCTR - RIGHT	3
AAU6149	CASTING - SHEET / ROPE CNNCTR - LEFT	3
AAU6150	CASTING - SHEET / ROPE BAND - RIGHT	3
AAU6151	CASTING - SHEET / ROPE BAND - LEFT	3
AAU6152	BUMPER - PLATFORM EDGE	9
AAU6153	BUMPER - 7.00" DIA INSERT	4
ABC0871	BRACKET - 9.28" x 27.96" ANCHOR	2
ACL0421	CLIMBER - 40.00" DIA TOP RING	1
ACL0422	CLIMBER - UNITY DOME LOOP - A	3
ACL0423	CLIMBER - UNITY DOME LOOP - B	3
AMC0613	UNITY DOME NET	1
AMC0620	PERCH POINT - 18.50" DIA x 1.25"	3
APL2048	PLATE - 11 GA x 27.50" DIA SUPPORT	1
BAD0085	THREAD LOCKING ADHESIVE	1
BAE0112	NUT - 3/8"-16 HEAVY HEX	6
BAE01525	BOLT - 1/4"-20 x 1-1/4" BUTTON HEAD - SS	18
BAE0161	NUT - 1/4"-20 x 7/16" BUTTON HEAD	18
BAE0595	WASHER - 3/8" SAE FLAT	27
BAE0600	WASHER - 1" O.D. FLAT	16
BAE0659	BOLT - 3/8"-16 x 3/4" BUTTON HEAD - SS	18
BAE0663	NUT - 3/8"-16 x 7/16" BUTTON HEAD	9
BAE0664	BOLT - 3/8"-16 x 1" BUTTON HEAD - SS	28
BAE06645	BOLT - 3/8"-16 x 1-1/2" BUTTON HEAD - SS	9
BAE0665	BOLT - 3/8"-16 x 1-3/4" BUTTON HEAD - SS	12
BAE0900	WRENCH - 5/32" SHORT HEX KEY	1
BAE0902	TOOL - 7/32" SHORT HEX KEY WRENCH	1
BAE0922	TOOL - TT 45 L WRENCH	2
BFC3532	SHEET - .75" x 30.00" DIA PLATFORM	1
ALB0025	LABEL - AGE APPROPRIATE SHEET	1



The world needs play.

For Customer Service, Call
800-233-8404 or
570-522-9800 OUTSIDE U.S.

1000 Buffalo Road • Lewisburg, PA 17837
www.playworldsystems.com



This page is
intentionally left blank.



Clamps

- Inspect the band clamps to insure they are properly secured to the rope connectors.

Fasteners

- Inspect for loose fasteners.
Tightening torque specifications are:
Bolts and Nuts: Snug tighten and tighten an additional one-half turn.
- If during the maintenance process a bolt needs to be removed from a part or parts, it will be necessary to apply a drop of liquid thread lock / loctite to the bolt before reinstallation.
- Inspect for missing, worn or broken fasteners. If any missing, worn or broken fasteners are found, refer to the installation instructions for proper replacement fastener. If any damage is detected, barricade equipment to prevent use until repair is completed. Contact your sales representative immediately for a replacement part.

Plastic Parts

- Inspect all plastic surfaces for sharp points, cracks or jagged edges. If any damage is detected and is determined to be unsafe, barricade equipment to prevent use until repair is completed. Minor burrs or sharp edges may be removed by using a sharp utility knife or block plane to remove sharp burr.

Castings

- Inspect the aluminum castings to insure they are properly secured to the component.
- Visually inspect the castings for cracks or breakage. If any damage is detected, barricade the equipment to prevent use until repair is completed. Contact your sales representative immediately for a replacement part.

Welds

- Inspect all welded joints. If any broken welds are detected, barricade equipment to prevent use until repair is completed. Contact your sales representative immediately for a replacement part.

Finish

- Inspect metal parts for finish damage.
To repair painted surfaces, sand damaged area with sandpaper and wipe clean. Mask area and paint with primer and allow to dry. Paint primed area with color-matching paint and allow to dry. Recoat area with color-matching paint if required. Drying time is approximately 8 hours between coats.

Footings

- Inspect component to be solid in or on the footings and secure. If any damage is detected, barricade equipment to prevent use until repair is completed.

Surfacing

- Refer to the specific surfacing maintenance detail sheet for additional information.

Replacement Parts

- Refer to your installation instructions to obtain replacement part number.
- Contact your sales representative or call Playworld Systems' Customer Service for a replacement part.

Equipment Maintenance Playworld Systems® Models XX0366 and XX0366S Unity Dome In-Ground and Surface Mount

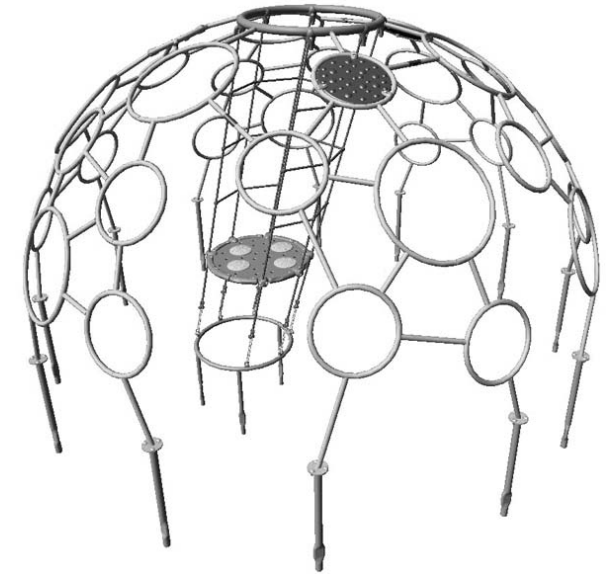

 **PLAYWORLD**
The world needs play.™

For Customer Service, Call
800-233-8404 or
570-522-9800 OUTSIDE U.S.
1000 Buffalo Road • Lewisburg, PA 17837
www.playworldsystems.com

Inspection Form

Preventive Maintenance

... for Safety's Sake!

- Be sure that you are using a copy of this Inspection Form and not your original.
- Use the Inspection Codes listed below and record condition of equipment at time of examination on the Inspection Checklist.
- Document any item from the Inspection Checklist that will require maintenance along with any corrective action on the Maintenance Schedule.
- Be sure to include appropriate dates and signatures on each section to properly document maintenance procedure.

INSPECTION CHECKLIST

	Frequency	Inspection Code	Date	Date Repairs Completed
Inspect plastic parts for damage.	Medium			
Inspect band clamps for tightness and damage.	High			
Inspect metal parts for structural and finish damage.	Medium			
Inspect for loose, missing, worn, or broken fasteners.	High			
Inspect footing to insure support is secure and footing is not damaged.	Low			
Inspect surfacing to insure proper depth and distribution.	High			

Inspection Codes
P = Pass F = Fail
NA = Not Applicable

Inspector: Name (Please Print) _____ Signature: _____ Date: ___ / ___ / ___

MAINTENANCE SCHEDULE

Item in Question	Description of Problem	Corrective Action	Date

Repairer: Name (Please Print) _____ Signature: _____ Date: ___ / ___ / ___



Important ! Please Read Completely Before Beginning Installation. According to a report published by the U. S. Consumer Product Safety Commission (C.P.S.C.) 72% of all playground injuries result from accidental falls. With this in mind, this equipment is designed to fill the need for safe yet challenging play. In conjunction with design efforts to reduce the possibilities of injuries, this equipment **must** be installed "Step by Step" per our installation instructions. As a new owner you are responsible for the correct installation, safe use, and maintenance of your equipment.

Installation Guidelines

- Identify all parts and thoroughly read the assembly instructions before beginning construction.
- Refer to your playground equipment plan and footing diagram to assure the equipment purchased will fit into your selected site area. The use and no-encroachment zones around the play equipment shall be obstacle-free areas designated for unrestricted circulation.
- **ASTM compliance:** The overall use zone measurements for stationary play equipment should extend a minimum of 72 inches (1829 mm) from its perimeter; dimensions and configuration of the use zone are dependent upon the types of included play equipment. The use zone of stationary play equipment may be overlapped by the use zone of adjacent stationary play equipment if the adjacent designated play surfaces are no greater than 30 inches (762 mm) above the protective surfacing level. They should be a minimum of 72 inches (1829 mm) apart. If the adjacent designated play surfaces are greater than 30 inches (762 mm) above the protective surfacing level, the pieces of equipment should be a minimum of 108 inches (2743 mm) apart.
- **CSA compliance:** The overall use zone measurements for stationary play equipment should extend a minimum of 1800 mm from its perimeter; dimensions and configuration of the use zone are dependent upon the types of included play equipment. The use zone of stationary play equipment may be overlapped by the use zone of adjacent stationary play equipment if the adjacent designated play surfaces are no greater than 700 mm above the protective surfacing level. They should be a minimum of 1800 mm apart.

- **EN compliance:** The overall use zone measurements for stationary play equipment are dependent upon the fall height of the equipment. For a fall height exceeding 1500 mm a formula is applied to determine the use zone (impact zone) of the equipment. There is a minimum of 1500 mm from its perimeter; dimensions and configuration of the use zone are dependent upon the types of included play equipment. Refer to the Use Zone diagram or master structure drawing.
- Site layout is a critical part of the overall installation. Footings must be measured and marked accurately according to the footing diagram. A level and clear installation site is ideal.
- Good drainage around the structure and its supports is important. Inquire with local contractors for appropriate recommendations.
- After laying out all footings and before digging holes, be sure to inquire about underground utilities that may exist.
- Do not leave the job site unattended without making sure that all fastening hardware on all components are tightened according to tightening torque specifications listed on every installation guide. We also recommend roping off construction area and covering all holes that do not contain a piece of equipment with plywood or other suitable material.
- Excavate holes as shown in the footing detail. If a level and clear site cannot be obtained, adjust the depth of footing to maintain a level footing base. If soil conditions are loose or unstable, a larger diameter footing may be required. Inquire with local contractors for appropriate recommendations. Be sure concrete that might have splashed onto the unit is washed off before it dries. Allow concrete to harden 72 hours before allowing your structure to be used. **Assemble the entire structure before pouring concrete unless specifically instructed to do so in the installation instructions.**
- Insure that Age Appropriate and Hard Surface Warning/Playworld Systems identification labels are properly affixed to the play equipment. Labels are to be plainly visible according to current playground equipment guidelines.

Guidelines

- **IMPORTANT!** Because accidental falls around your playground equipment can occur, Playworld Systems recommends that the area under and around the structure be covered with a resilient material such as sand, bark mulch, or wood chips. If loose fill surfacing materials are used, Playworld Systems recommends a depth of 12 in. (305 mm). An approved rubber safety matting can also be used. **Many protective surfacing materials can become compacted due to weather and use, which reduces their shock absorbency. It is strongly recommended that the surfacing be checked weekly and material added or replaced as necessary. Hard surfaces, such as asphalt, concrete and packed earth are not acceptable for use under playground equipment.**

- The entire area, under and around the playground equipment, must be covered with protective surfacing material. The impact attenuation of the protective surfacing under and around playground equipment should be rated to have a critical height value of at least the height of the highest accessible part of the equipment. The critical height for surfacing is to be rated in accordance with A.S.T.M. standard, designated F1292, A Standard Specification for Impact Attenuation of Surface Systems Under and Around Playground Equipment. Critical fall heights for Europe and Canadian compliance shall be listed on the elevation page or master structure drawing if they differ from the ASTM standard. Contact the manufacturer of unitary surfacing materials (rubber matting) for the critical height rating for their products.

Tools Required: Playworld Systems supplies a service kit that contains commonly used hex key wrenches required to assemble your equipment. You may also need: shovel, digging iron, post hole digger, steel rake, wheelbarrow, garden hoe, water hose, tape measure, level, alignment tool, 3/8" ratchet with 9/16" socket, and 9/16" combination wrench.

Maintenance

- Inadequate maintenance of equipment has resulted in injuries on the playground. Because the safety of playground equipment and its stability depends on good inspection and maintenance, **a comprehensive maintenance program must be developed for each playground and strictly followed.** All equipment must be inspected frequently for any potential hazards. Special attention must be given to moving parts and other components that can be expected to wear. Inspections must to be carried out in a systematic manner by trained personnel. Any damaged or worn parts, or any other hazards identified during inspections must be repaired or replaced immediately. Complete documentation of all maintenance inspections and repairs must be retained.

Supervision Guidelines

- Playworld Systems strongly recommends close supervision of the children as they play as well as intensive classroom and home instruction about safe behavior on playground equipment.
- Playground supervisors should be aware that not all playground equipment is appropriate for all children who may use the playground. Signs should be posted near the equipment indicating the recommended age of the users. Supervisors should direct children to equipment appropriate for their age.
- It is important that playground supervisors recognize that preschool-age children require more attentive supervision on playgrounds than older children.
- Do not permit the use of wet playground equipment. Wet equipment will inhibit necessary traction and gripping capabilities. Slips or falls could occur.
- Do not permit too many children on the same piece of equipment at the same time. It is suggested that children take turns.
- Constantly observe play patterns to discover possible hazardous play and suggest changes in equipment use or play patterns.

Footings Details (in ground)

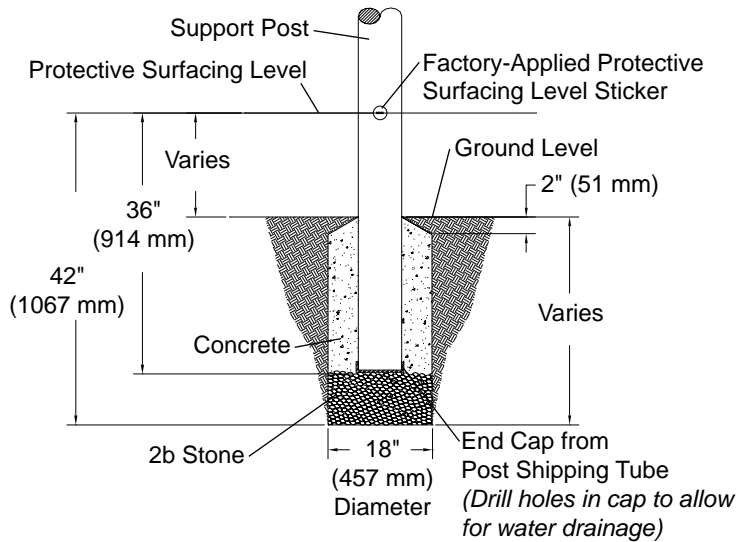

Support Post Footing Detail (ASTM/CSA)

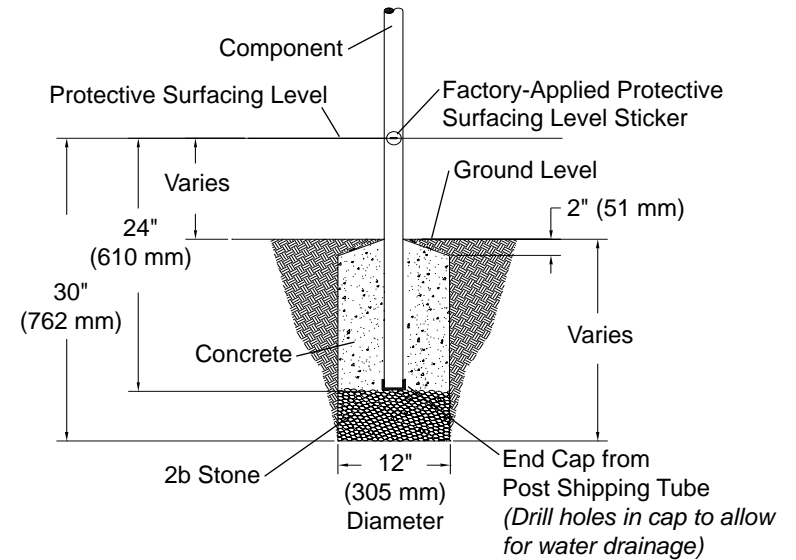

Component Footing Detail (ASTM/CSA)

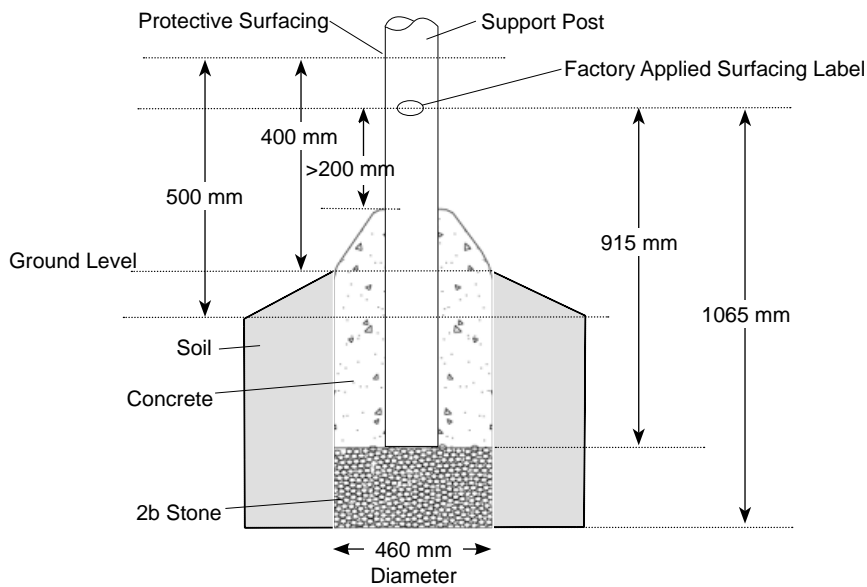

Footing Detail - Support Post (EN)

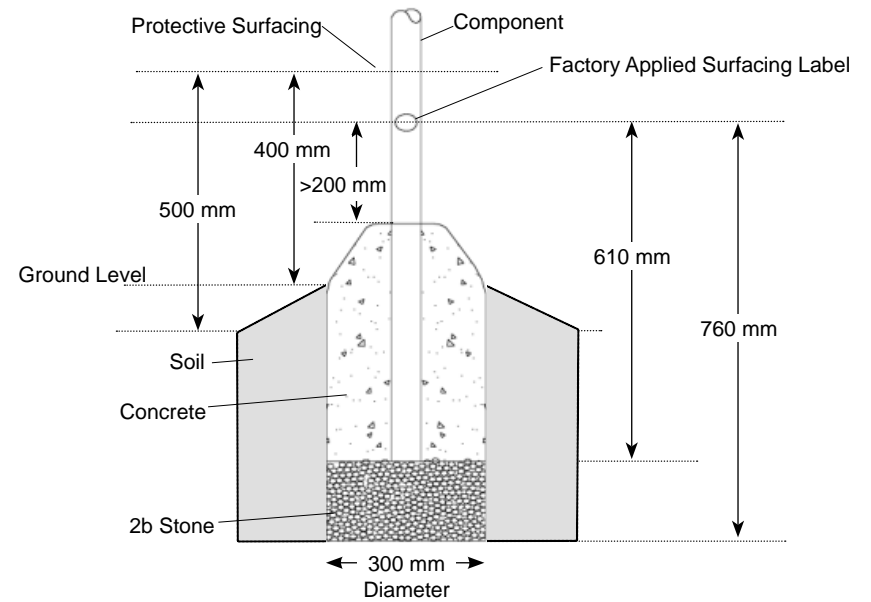

Footing Detail - Component Post (EN)

Footing Notes (in ground)

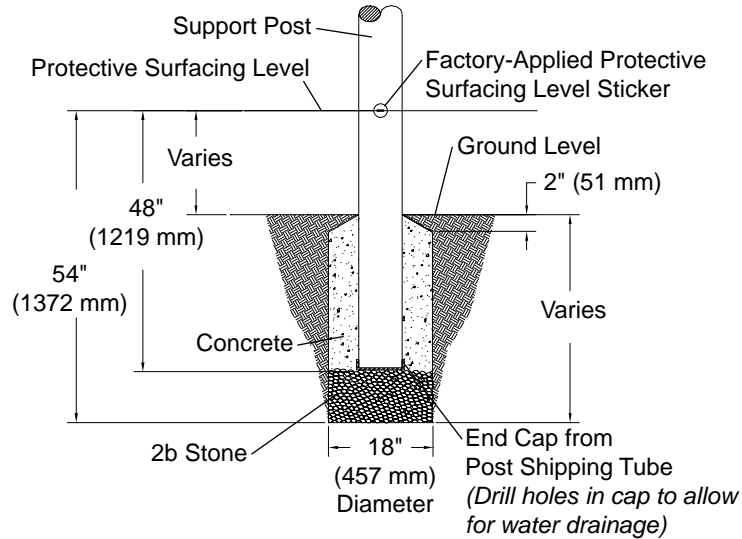

GroundZero® Support Post Footing Detail ASTM/CSA

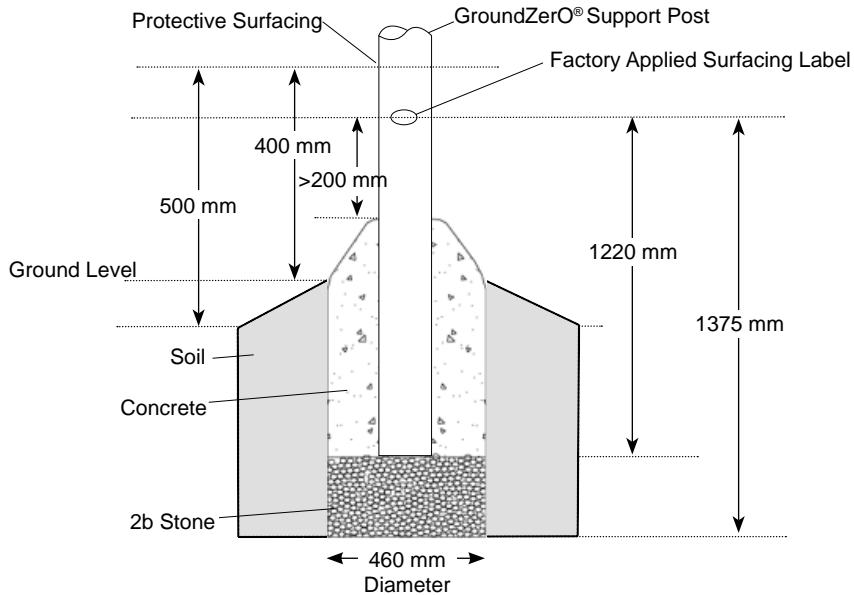

Footing Detail - GroundZero® Support Post (EN)

IN GROUND FOOTING DIAGRAMS-BLOCK OPTION

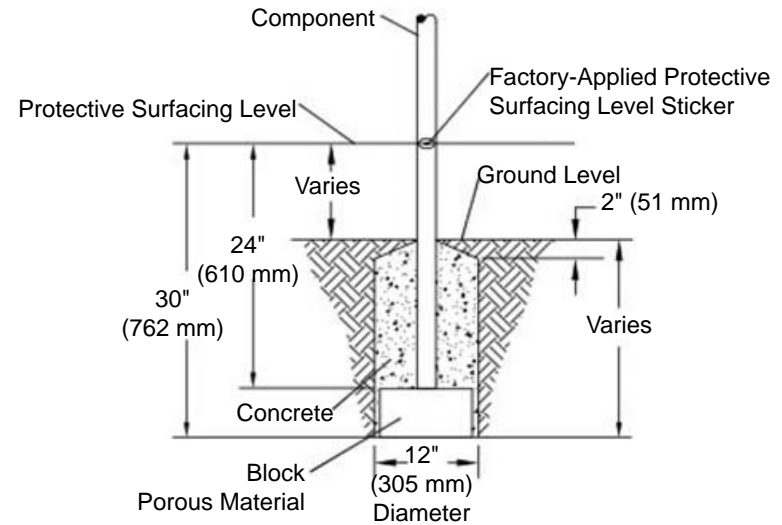

Component Footing Detail (ASTM/CSA) Block Option

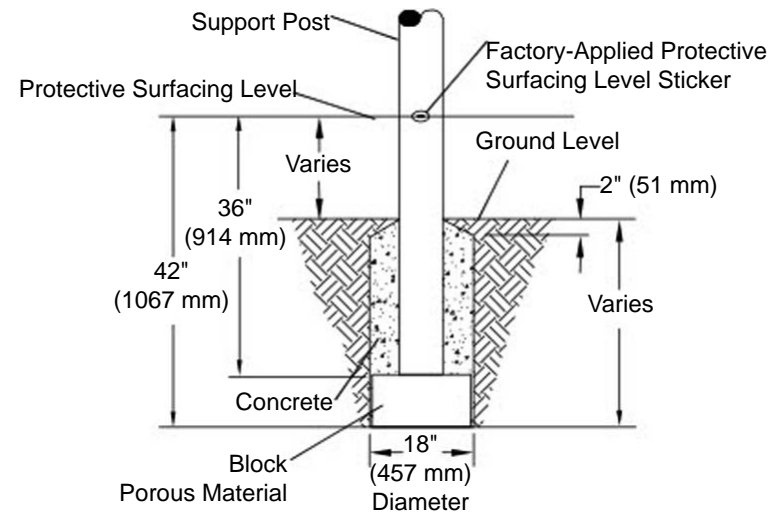

Support Post Footing Detail (ASTM/CSA) Block Option

Footings Notes & Details (in ground)

IN GROUND FOOTING DIAGRAMS-BLOCK OPTION

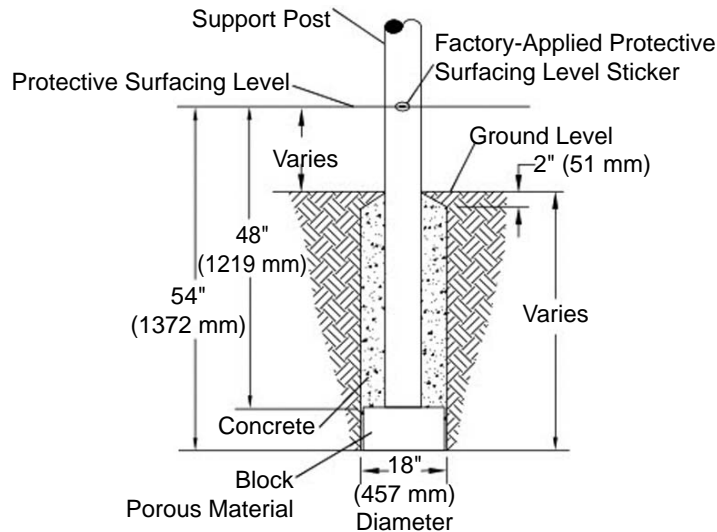

GroundZero® Support Post Footing Detail ASTM/CSA
Block Option

FOOTING NOTES (IN GROUND)

- Support post footing depth equals 42 in. (1067 mm) minus the depth of the protective surfacing material. The posts are designed to have 24" (610 mm) in concrete.
Example: If 12 in. (305 mm) of wood mulch is used for surfacing, the footing depth would be 30 in. (762 mm).
GroundZero® posts are footed 12 in. (305 mm) deeper than the regular support posts, and will be marked as such on the master footing diagram.
- Component footing depth equals 30 in. (762 mm) minus the depth of the protective surfacing material. The posts are designed to have 12" (305 mm) in concrete.
Example: If 12 in. (305 mm) of wood mulch is used for surfacing, the footing depth would be 18 in. (457 mm).
- Most support posts and component support legs will have either a factory-applied sticker with a line, or factory-applied mark designating the level of protective surfacing on a clear and level installation site. The footing depth measurements are based on this line/mark.
- If the play equipment is installed on uneven terrain, maintain support post mark for the protective surfacing level at the lowest grade. Adjust other footings accordingly. Support posts and all attaching decks and play components must be plumb and level.
- Do not encase the bottom of the support post in concrete. Place the post directly on packed stone or other porous material.
- The footings shown on Playworld Systems' documentation are recommendations based on historical performance in average soil conditions. Footing dimensions may be modified by the owner based on actual soil conditions.
For example:
 - If local soil is loose or unstable, a larger footing may be required.
 - If local soil is considered stable, such as bedrock, clay or hard packed earth, a smaller footing may be used. Before changing footing dimensions, we strongly recommend that the footings be reviewed and approved by a registered engineer.
- The base of the footing must be below the frost line.
- Assemble the entire structure before pouring concrete unless specifically instructed to do so in the installation instructions.

Footings Notes & Details (surface mount)

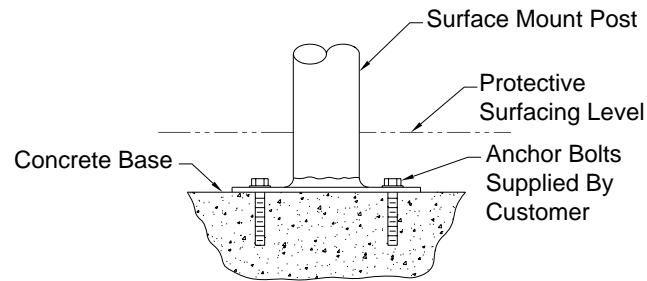

Surface Mount Footing Detail

FOOTING NOTES (SURFACE MOUNT)

- Most support posts and component support legs will have either a factory-applied sticker with line, or factory-applied mark designating protective surfacing level on a clear and level installation site.
- If the play equipment is installed on uneven terrain, maintain support post mark for the protective surfacing level at the lowest grade. Adjust other footings accordingly. Support posts and all attaching decks and play components must be plumb and level.
- The footing size may vary due to local soil and weather conditions.
- Base of footing must be below frost line.

Surface mount hardware is not supplied. Customer is responsible for concrete base and providing surface mount hardware as specified by a registered structural engineer for each specific project application.

FINAL INSPECTION

- Playworld Systems® insists on the installation of protective surfacing within the use zone of each play structure in accordance with the applicable standard or specifications appropriate for the fall height of each structure.
- Playworld Systems® strongly recommends close supervision of children as they play. The owners of playground equipment and the parents or guardians of children are responsible for this proper supervision.
- As the owner of playground equipment, you are responsible for the maintenance of the equipment and surrounding play area. A comprehensive maintenance and inspection schedule must be developed and all equipment inspected frequently. Refer to the inspection and maintenance schedule in the back of this booklet.
- Perform a thorough final check on the installed equipment to insure all equipment is installed as specified by manufacturer's installation instructions.
 - Review all Installation Instructions for specified dimensions. Make sure dimensions called for in instructions agree with actual installation.
 - Double check height dimensions. Height measurements are taken from the top of the protective surfacing material.
 - Insure all fasteners are tightened according to tightening torque specifications listed on your installation instructions.
 - Insure all exposed pipe ends have properly installed end caps. Insure that drive rivets are secure.
 - Clean dried concrete off of components and any other affected surface.
 - Touch-up any scratches or installation damage to powder coated finish with color-matched spray paint.
 - Allow adequate time for proper curing, both for concrete and urethane cement if rubber safety surfacing tiles have been installed.
 - Insure that protective surfacing is properly installed according to C.P.S.C. (or other appropriate body) recommendations. Footings must not be exposed.
- Insure that hard surface warning/Playworld Systems® identification labels are properly affixed to the play equipment. Labels are to be plainly visible according to current playground equipment guidelines. For locations complying with ASTM F1487 or CSA Z-614, Age Appropriate labels must also be applied in a visible location.
- Dispose of all packaging material properly. These materials which include large plastic bags and sheets can be a suffocation hazard. Dispose of these materials out of reach or contact of small children.

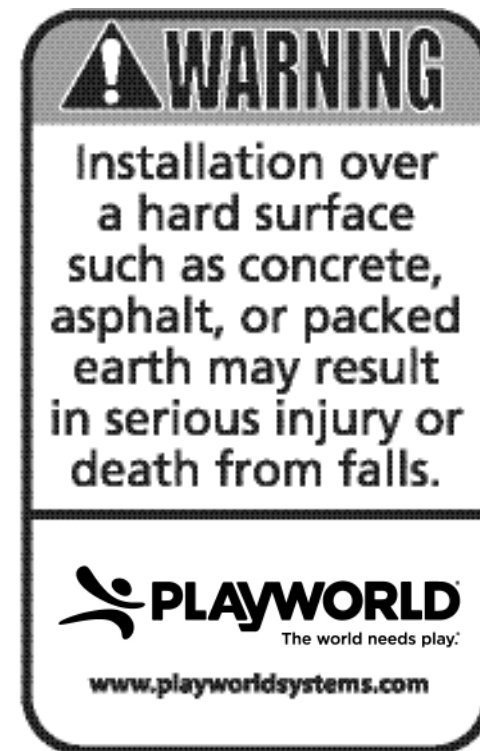

Surfacing Warning Label